

APPENDIX D

DETAILED DRAWINGS

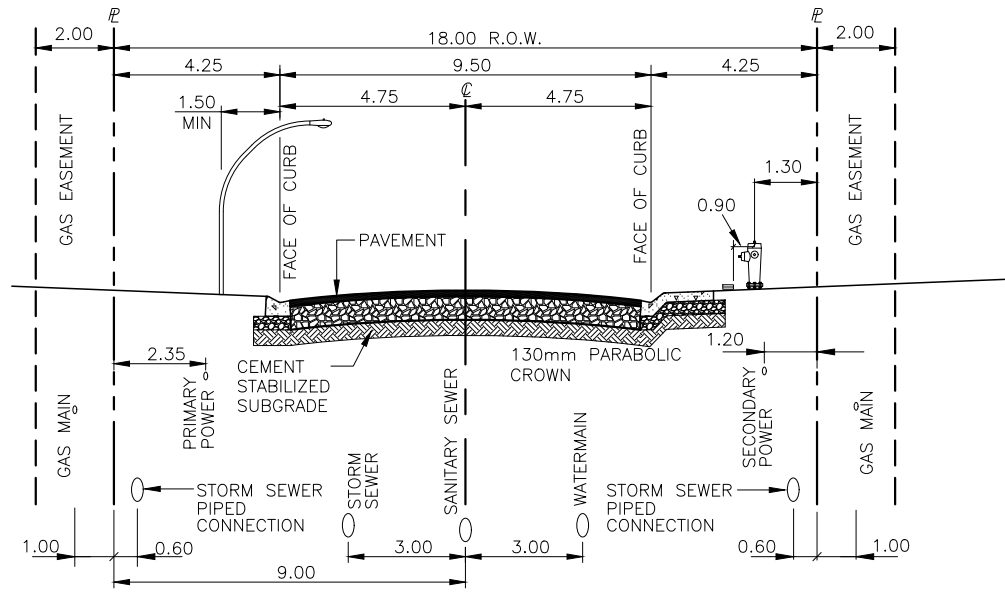

MONO-WALK

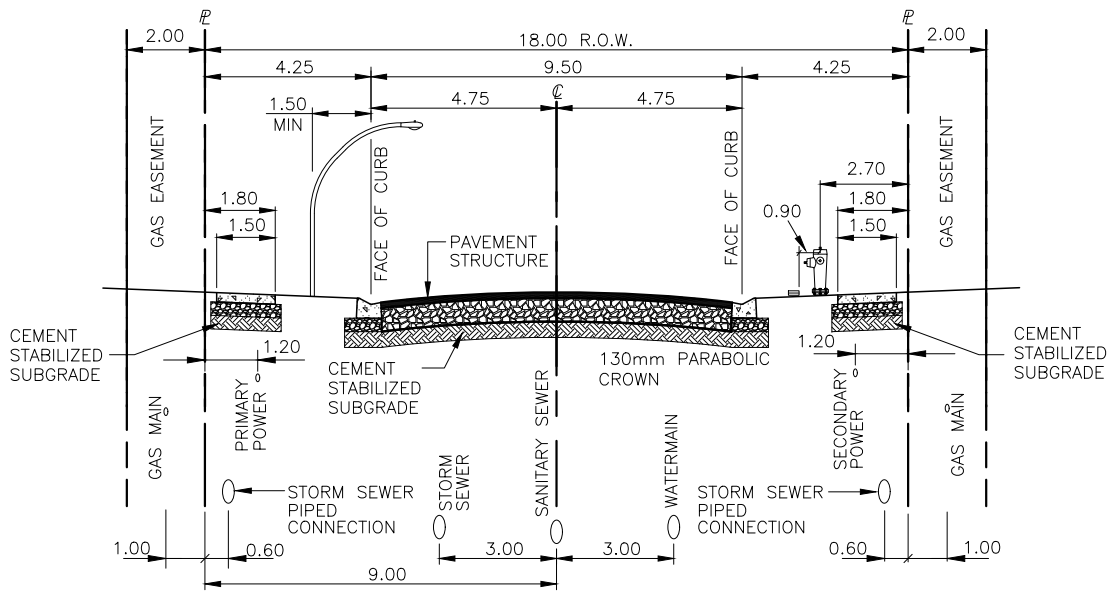

SEPARATE WALK

- NOTES:
1. MINIMUM 150mm GRAVEL UNDER ALL CONCRETE STRUCTURES
 2. ENSURE 0.5m CLEARANCE BETWEEN POWER AND HYDRANTS
 3. EXTEND SUBGRADE AND GRAVEL BASE 300mm BEYOND BACK OF CURB OR EDGE OF MONO-WALK
 4. EXTEND SUBGRADE AND GRAVEL BASE 150mm BEYOND EDGE OF SEPARATE WALK

**THE CITY OF
SPRUCE GROVE**

PLANNING AND INFRASTRUCTURE

REVISIONS

DATE	DETAILS	DRAWN
03/13	Cement Stabilized Subgrade	SW
02/14	Additional Notes	RP
02/14	Location of Primary Power	RP
02/21	Extend Base & Subgrade	AS

LOCAL RESIDENTIAL ROADWAYS



DRAWN:	T. CRAWFORD	DATE:	MARCH 6, 2006
CHECKED:	J. MUSTARD	SCALE:	NOT TO SCALE
APPROVED:	J. MUSTARD	DRAWING No.:	CS-01

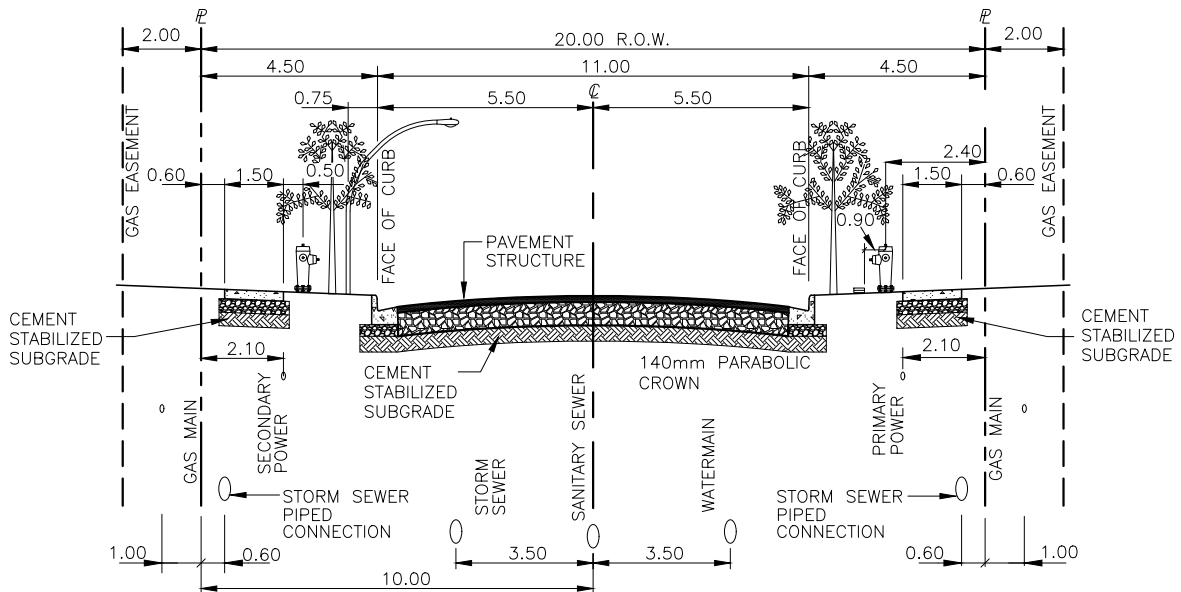

MINOR COLLECTOR RESIDENTIAL
TRAFFIC VOLUMES < 2500 vpd

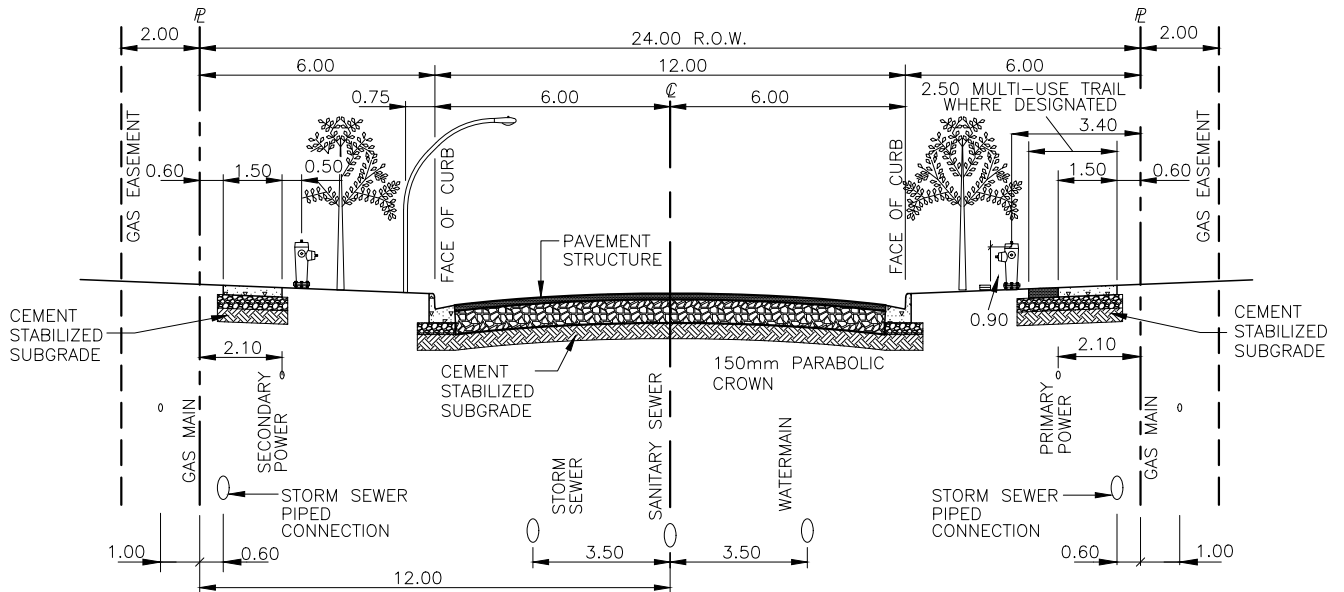

MAJOR COLLECTOR RESIDENTIAL
TRAFFIC VOLUMES > 2500 vpd
NO FRONT ACCESS > 4000 vpd

NOTES:

1. MINIMUM 150mm GRAVEL UNDER ALL CONCRETE STRUCTURES
2. ENSURE 0.5m CLEARANCE BETWEEN POWER AND HYDRANTS
3. EXTEND SUBGRADE AND GRAVEL BASE 300mm BEYOND BACK OF CURB
4. EXTEND SUBGRADE AND GRAVEL BASE 150mm BEYOND EDGE OF SEPARATE WALK
5. WHERE MULTI-USE ASPHALT TRAIL IS DESIGNATED, SUBGRADE AND GRAVEL BASE TO BE PREPARED AS PER ASPHALT TRAIL DETAIL LG-07

**THE CITY OF
 SPRUCE GROVE**

PLANNING AND INFRASTRUCTURE

REVISIONS

DATE	DETAILS	DRAWN
03/13	Cement Stabilized Subgrade	SW
02/14	Additional Notes	RP
02/21	Extend Base & Subgrade	AS

RESIDENTIAL COLLECTOR ROADS



DRAWN: T. CRAWFORD	DATE: MARCH 6, 2006
CHECKED: J. MUSTARD	SCALE: NOT TO SCALE
APPROVED: J. MUSTARD	DRAWING No.: CS-02

XREFS

C:\DETAILS\SHEET2-TK

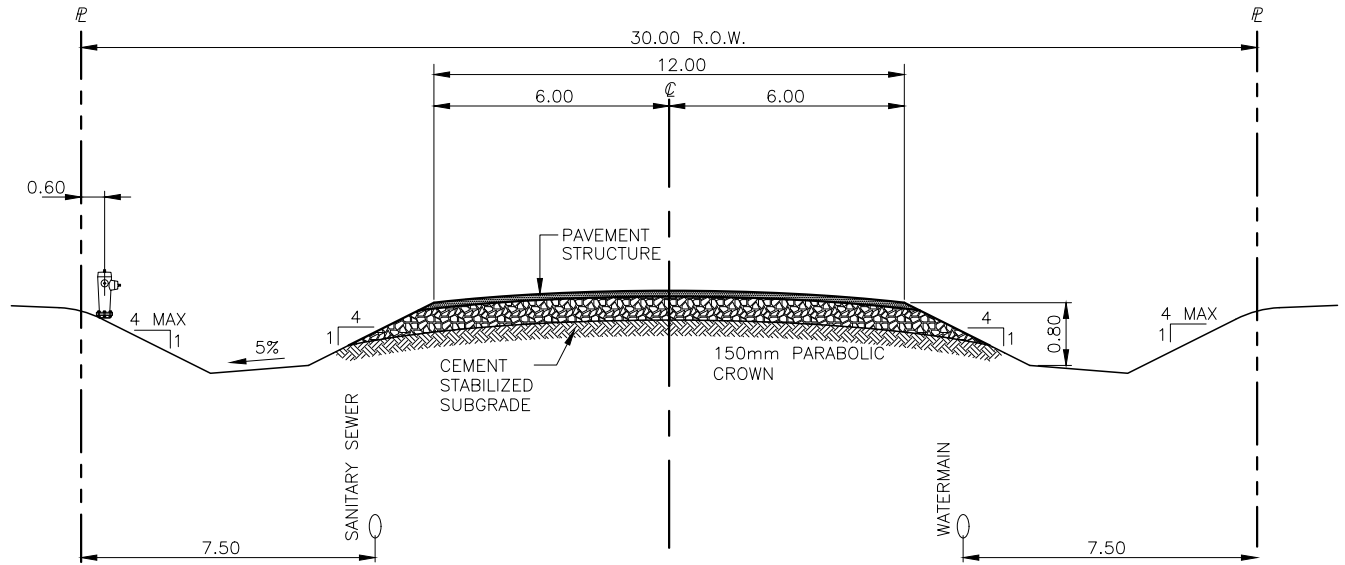

RURAL INDUSTRIAL

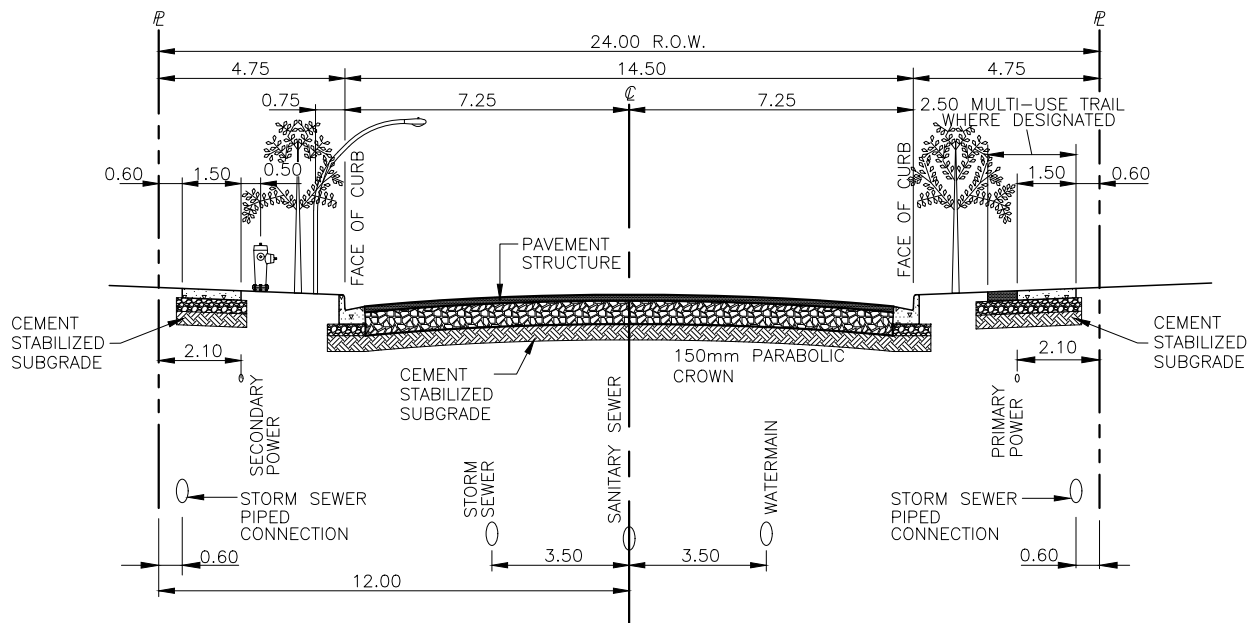

URBAN INDUSTRIAL/COMMERCIAL

NOTES:

1. MINIMUM 150mm GRAVEL UNDER ALL CONCRETE STRUCTURES
2. ENSURE 0.5m CLEARANCE BETWEEN POWER AND HYDRANTS
3. EXTEND SUBGRADE AND GRAVEL BASE 300mm BEYOND BACK OF CURB
4. EXTEND SUBGRADE AND GRAVEL BASE 150mm BEYOND EDGE OF SEPARATE WALK
5. WHERE MULTI-USE ASPHALT TRAIL IS DESIGNATED, SUBGRADE AND GRAVEL BASE TO BE PREPARED AS PER ASPHALT TRAIL DETAIL LG-07

**THE CITY OF
SPRUCE GROVE**

PLANNING AND INFRASTRUCTURE

REVISIONS

DATE	DETAILS	DRAWN
03/13	Cement Stabilized Subgrade	SW
02/14	Additional Notes	RP
02/21	Extend Base & Subgrade	AS

INDUSTRIAL/COMMERCIAL ROADS



DRAWN: T. CRAWFORD

DATE: MARCH 6, 2006

CHECKED: J. MUSTARD

SCALE: NOT TO SCALE

APPROVED: J. MUSTARD

DRAWING No.: CS-03

XREFS

C:\DETAILS\SHEET2-TK

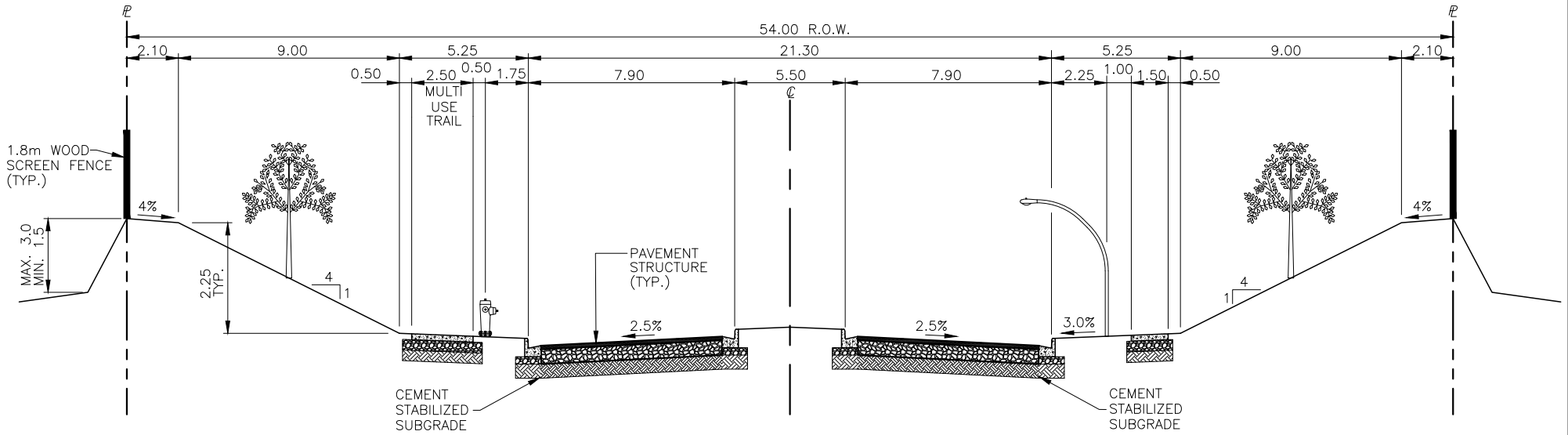

NOTES:

1. MINIMUM 150mm GRAVEL UNDER ALL CONCRETE STRUCTURES
2. ENSURE 0.5m CLEARANCE BETWEEN POWER AND HYDRANTS
3. EXTEND SUBGRADE AND GRAVEL BASE 300mm BEYOND BACK OF CURB
4. EXTEND SUBGRADE AND GRAVEL BASE 150mm BEYOND EDGE OF SEPARATE WALK
5. WHERE MULTI-USE ASPHALT TRAIL IS DESIGNATED, SUBGRADE AND GRAVEL BASE TO BE PREPARED AS PER ASPHALT TRAIL DETAIL LG-07

THE CITY OF SPRUCE GROVE			PLANNING AND INFRASTRUCTURE		
REVISIONS			4 LANE DIVIDED ARTERIAL		
DATE	DETAILS	DRAWN		DRAWN: T. CRAWFORD	DATE: MARCH 6, 2006
03/13	Cement Stabilized Subgrade	SW		CHECKED: J. MUSTARD	SCALE: NOT TO SCALE
02/14	Additional Notes	RP		APPROVED: J. MUSTARD	DRAWING No.: CS-04
02/21	Extend Base & Subgrade	AS			

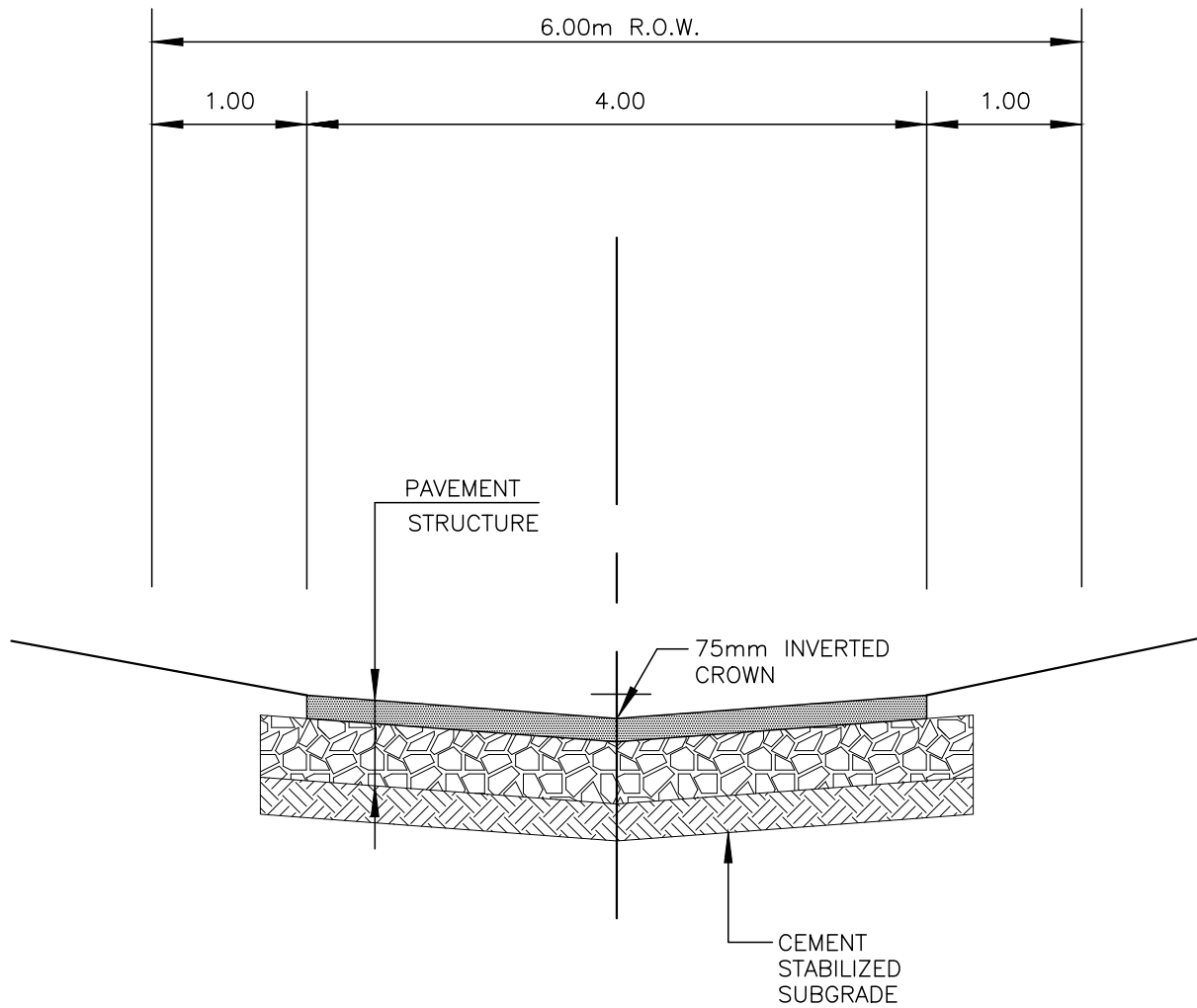

NOTE:
EXTEND SUBGRADE AND GRAVEL BASE 300mm BEYOND EDGE OF ASPHALT

XREFS

THE CITY OF
SPRUCE GROVE

PLANNING AND INFRASTRUCTURE

REVISIONS

DATE	DETAILS	DRAWN
03/13	Cement Stabilized Subgrade	SW
02/21	Extend Base & Subgrade	AS

TYPICAL LANE



DRAWN: T. CRAWFORD	DATE: MARCH 6, 2006
CHECKED: J. MUSTARD	SCALE: NOT TO SCALE
APPROVED: J. MUSTARD	DRAWING No.: CS-05

C:\DETAILS\SHEET2-TK

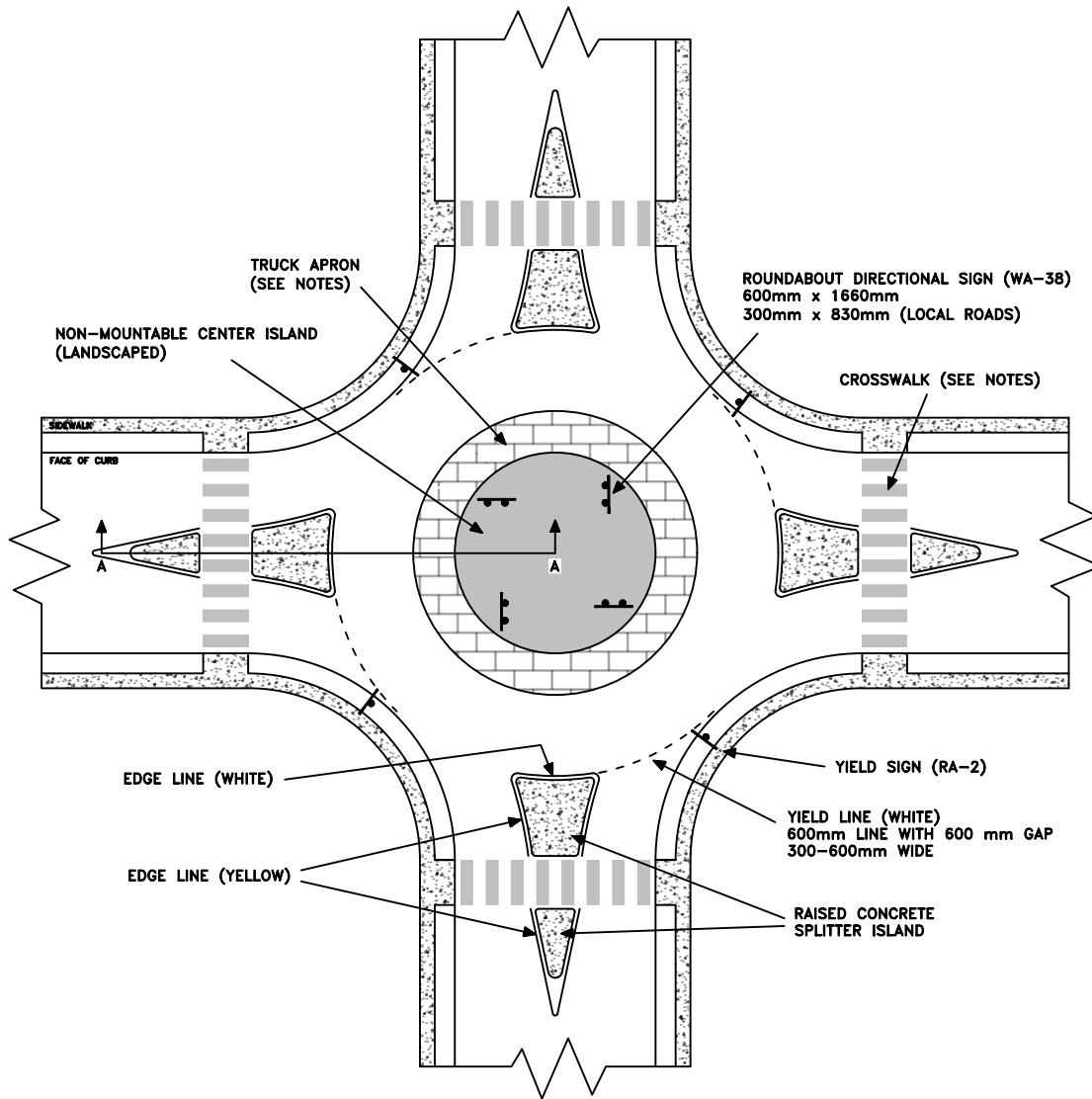

SECTION A-A

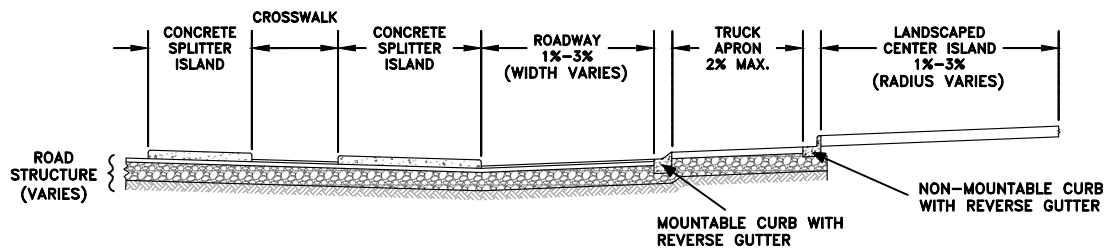

NOTES:

1. ROUNDABOUT DESIGN SHALL BE IN ACCORDANCE WITH THE TAC CANADIAN ROUNDABOUT DESIGN GUIDE.
2. REFER TO MUTCDC FOR SIGN INSTALLATION AND PAVEMENT MARKING GUIDELINES.
3. TRUCK APRON SHALL BE BRICK INLAY OR OTHER CITY APPROVED MATERIAL.
4. SEE DRAWING DETAIL SN-08 FOR CROSSWALK TREATMENT DETAILS.

THE CITY OF
SPRUCE GROVE

PLANNING AND INFRASTRUCTURE

REVISIONS

DATE	DETAILS	DRAWN

SINGLE LANE ROUNDABOUT



DRAWN: H. WHITE

DATE: JANUARY 26, 2022

CHECKED: D. FLYNN

SCALE: NOT TO SCALE

APPROVED: D. FLYNN

DRAWING No.: CS-06

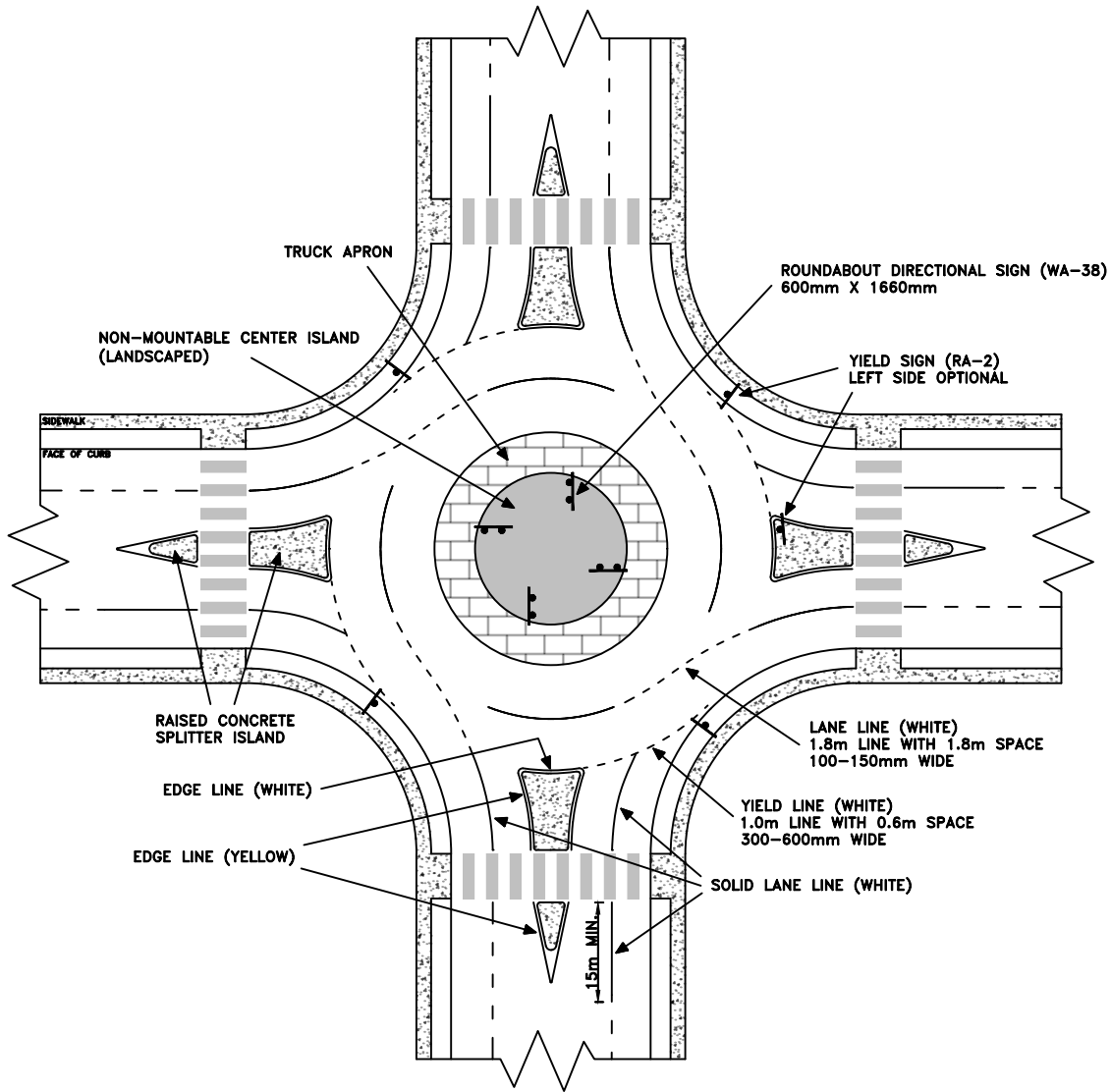

SECTION A-A

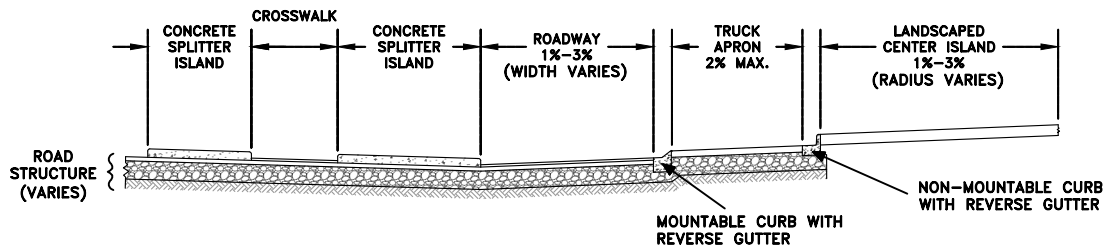

NOTES:

1. ROUNDABOUT DESIGN SHALL BE IN ACCORDANCE WITH THE TAC CANADIAN ROUNDABOUT DESIGN GUIDE.
2. REFER TO MUTCDC FOR SIGN INSTALLATION AND PAVEMENT MARKING GUIDELINES.
3. TRUCK APRON SHALL BE BRICK INLAY OR OTHER CITY APPROVED MATERIAL.
4. SEE DRAWING DETAIL SN-08 FOR CROSSWALK TREATMENT DETAILS.

THE CITY OF
SPRUCE GROVE

PLANNING AND INFRASTRUCTURE

REVISIONS

DATE	DETAILS	DRAWN

MULTI LANE ROUNDABOUT



DRAWN: H. WHITE

DATE: FEBRUARY 10, 2022

CHECKED: D. FLYNN

SCALE: NOT TO SCALE

APPROVED: D. FLYNN

DRAWING No.: CS-07

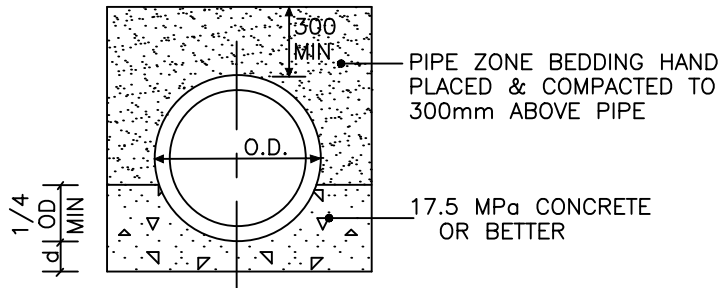

CONCRETE CRADLE

CLASS A

d = DEPTH OF BEDDING BELOW PIPE
 I.D. = 675 OR SMALLER -
 d MIN = 75
 I.D. = 750 TO 1500 -
 d MIN = 100
 I.D. = 1650 & LARGER -
 d MIN = 150
 O.D. = OUTSIDE PIPE DIAMETER

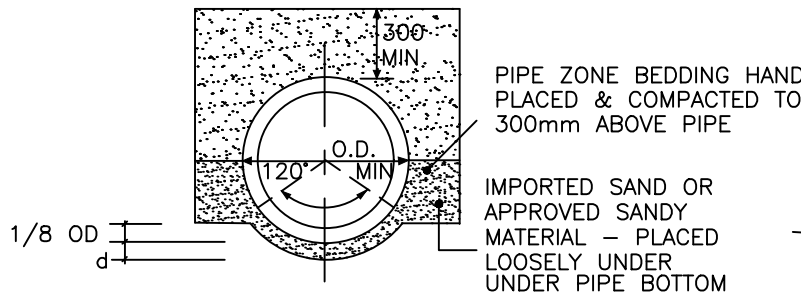

SHAPED SUBGRADE WITH GRANULAR FOUNDATION

CLASS B

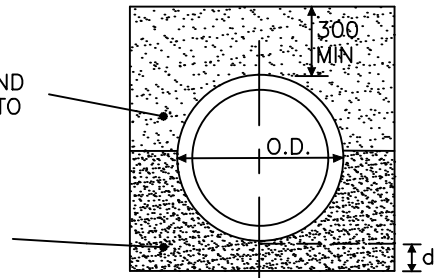

GRANULAR FOUNDATION

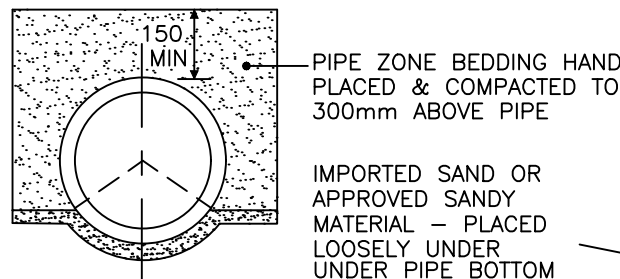

SHAPED SUBGRADE WITH GRANULAR FOUNDATION

CLASS C

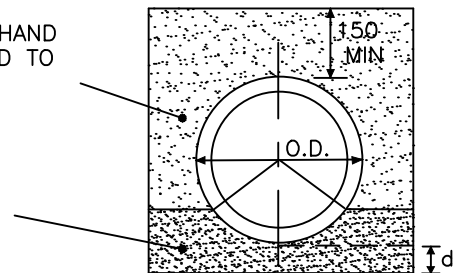

GRANULAR FOUNDATION

- NOTE: 1. FOR ROCK OR OTHER INCOMPRESSIBLE MATERIALS, THE TRENCH SHOULD BE OVEREXCAVATED A MINIMUM OF 150mm AND REFILLED WITH GRANULAR MATERIAL.
 2. PIPE ZONE SAND MATERIALS MUST BE HAND TAMPED UNDER PIPE HAUNCHES.
 3. PIPE ZONE SAND TO BE COMPACTED TO 97% OF A STANDARD PROCTOR DENSITY.
 4. ALL DIMENSIONS ARE IN MILLIMETERS UNLESS OTHERWISE INDICATED

THE CITY OF
 SPRUCE GROVE

PLANNING AND INFRASTRUCTURE

REVISIONS

DATE	DETAILS	DRAWN
04/19	Standards Update	WPS
09/20	Standards Update	CA

PIPE BEDDING TYPES



DRAWN: C. ALBARDA	DATE: SEPTEMBER 3, 2020
CHECKED: B HANSEN	SCALE: NOT TO SCALE
APPROVED: L. KRUSZEWSKI	DRAWING No.: GL-01

XREFS

C:\DETAILS\SHEET2-TK

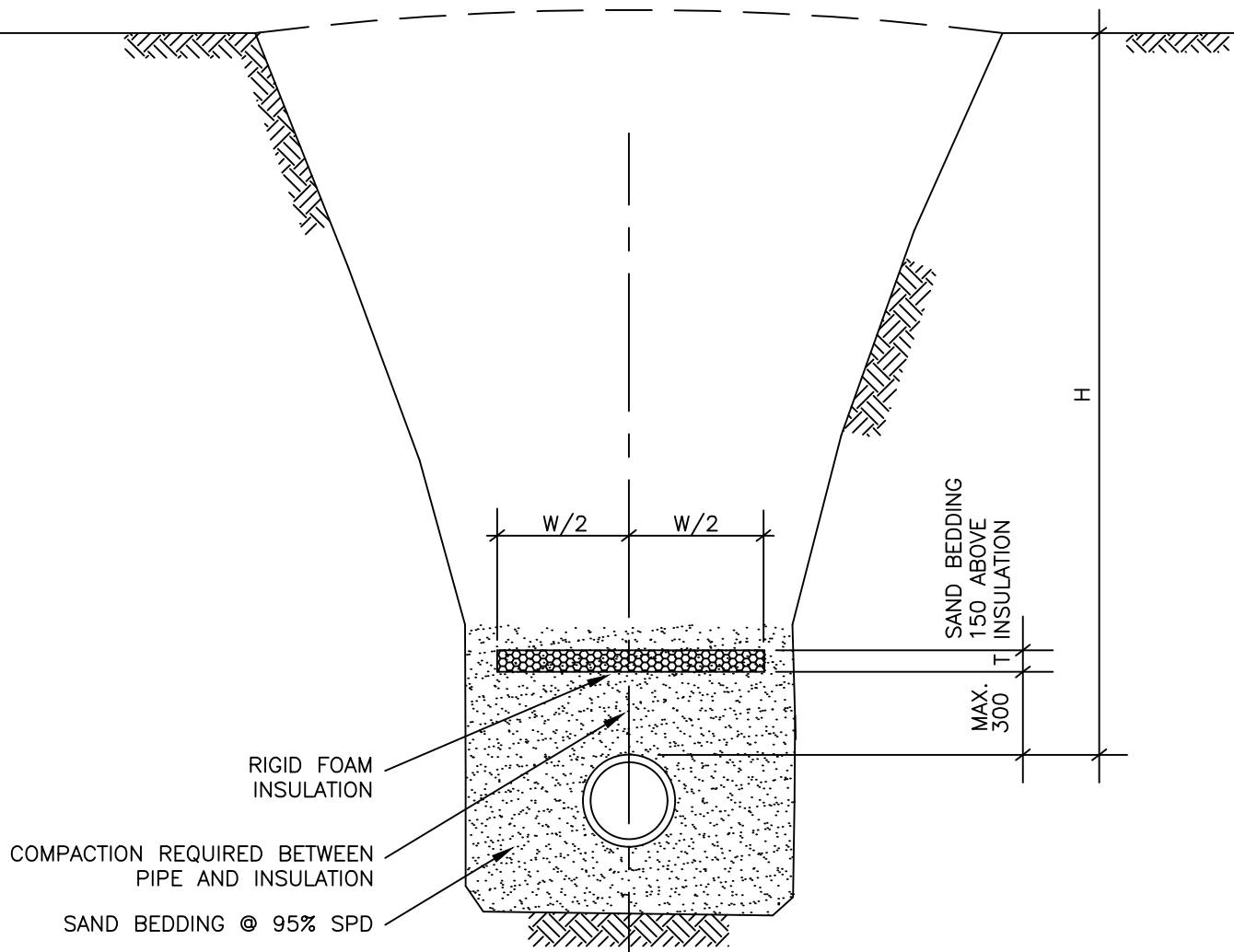

MAIN DEPTH, GROUND SURFACE TO TOP OF MAIN (H)	THICKNESS (T)	MIN. WIDTH (W) *
m	mm	m
0-1.2	N/R	N/R
1.2-1.5	175	3.4
1.5-1.8	125	2.8
1.8-2.1	125	2.2
2.1-2.4	75	1.6
2.4-2.7	50	1.0
2.7-3	25	1.0
3.0 OR MORE	0	0

N/R - NOT RECOMMENDED
 * WHERE TRENCH IS LESS THAN MIN. WIDTH, USE FULL TRENCH WIDTH

- NOTE:
 1. ALL DIMENSIONS ARE IN MILLIMETERS UNLESS OTHERWISE INDICATED
 2. FOLLOW MANUFACTURER INSTRUCTIONS IF MORE STRINGENT THAN THIS DETAIL

THE CITY OF SPRUCE GROVE **PLANNING AND INFRASTRUCTURE**

REVISIONS			INSULATION REQUIREMENTS				
DATE	DETAILS	DRAWN					
04/19	Standards Update	WPS		DRAWN:	C. ALBARDA	DATE:	FEBRUARY 10, 2022
09/20	Standards Update	CA		CHECKED:	B. HANSEN	SCALE:	NOT TO SCALE
02/22	Standards Update			APPROVED:	L. KRUSZEWSKI	DRAWING No.:	GL-02

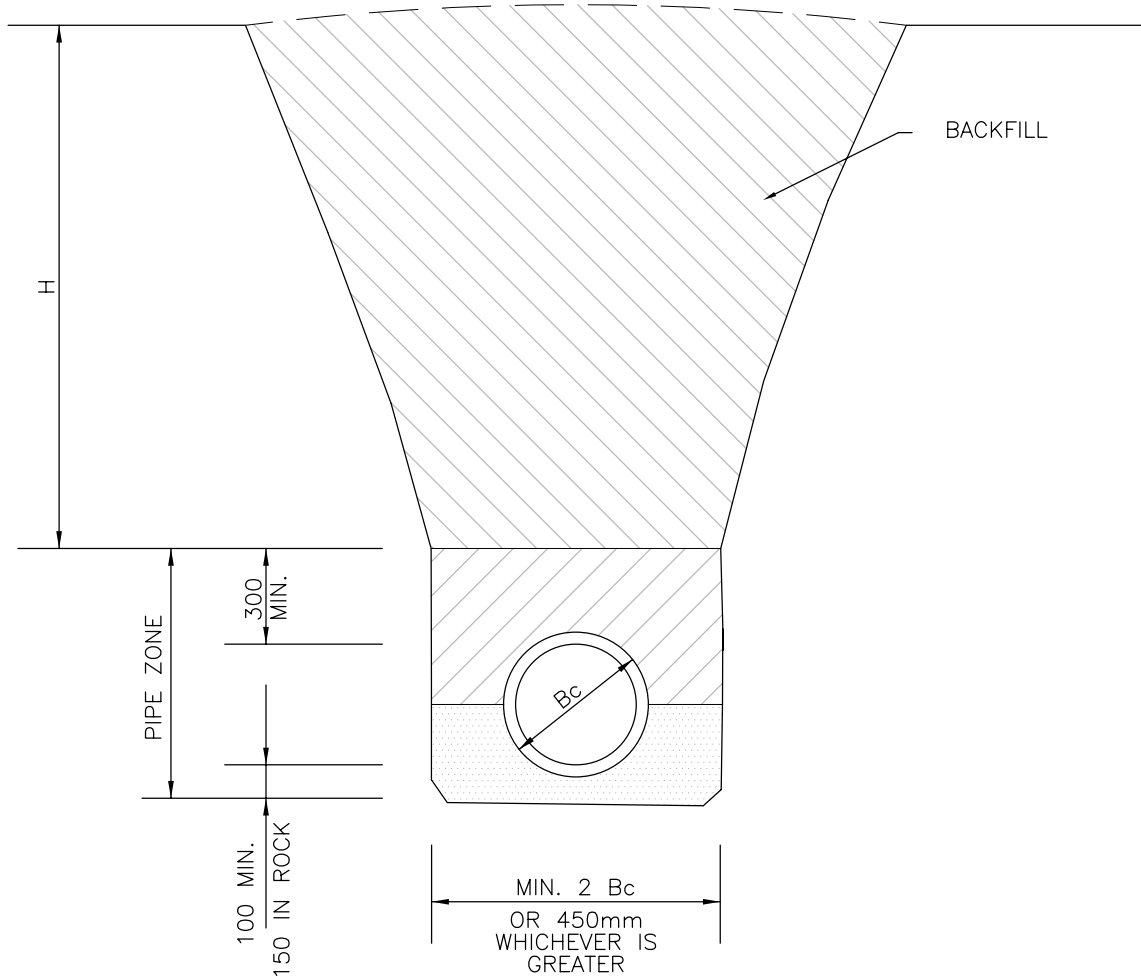

NOTES:

1. WHEN CUT BACK SLOPES ARE TO BE USED IN LIEU OF CAGES AND SHORING, THESE SLOPES ARE TO MEET REQUIREMENTS OF LOCAL CODES.
2. SEE SPECIFICATIONS FOR MINIMUM COVER ABOVE PIPE.
3. MIN. PIPE ZONE WIDTH IS SPECIFIED TO ALLOW PROPER PIPE ZONE COMPACTION.
4. Bc = OUTSIDE PIPE DIAMETER.
5. FOR UNCOMPACTED BACKFILL, CROWN TRENCH BY 0.1 x H.

XREFS

THE CITY OF
SPRUCE GROVE

PLANNING AND INFRASTRUCTURE

C:\DETAILS\SHEET2-TK

REVISIONS			TRENCH DETAIL		
DATE	DETAILS	DRAWN			
				DRAWN: T. CRAWFORD	DATE: MARCH 6, 2006
				CHECKED: J. MUSTARD	SCALE: NOT TO SCALE
				APPROVED: J. MUSTARD	DRAWING No.: GL-03

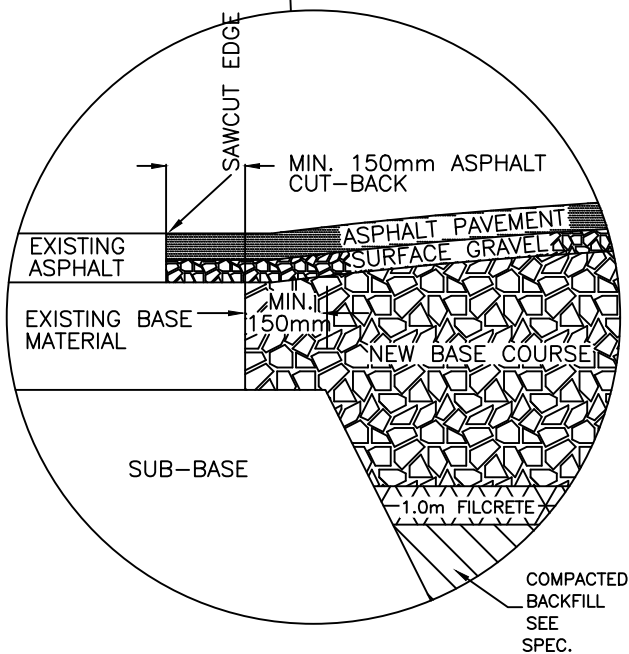
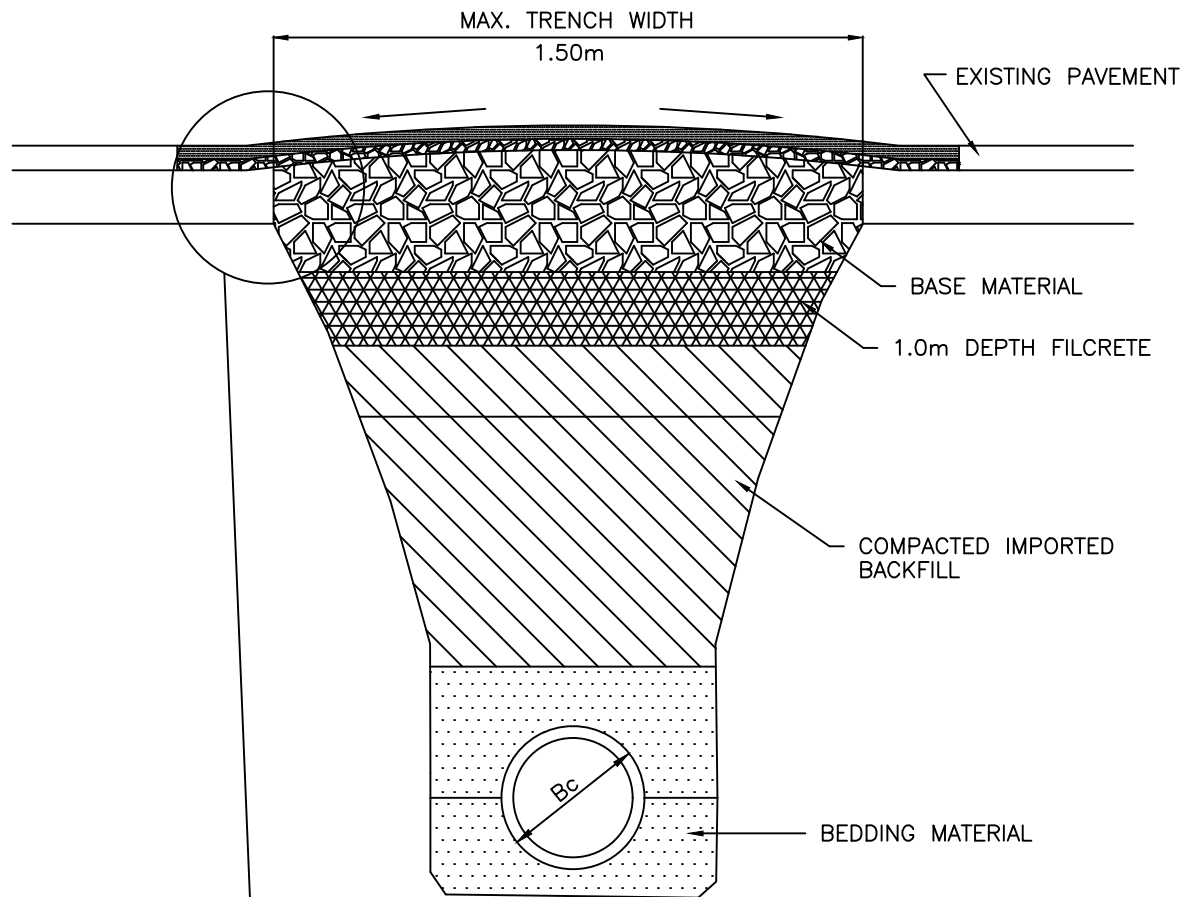

XREFS

C:\DETAILS\SHEET2-TK

THE CITY OF
SPRUCE GROVE

PLANNING AND INFRASTRUCTURE

REVISIONS

DATE	DETAILS	DRAWN
02/14	Added Filcrete	RP
04/19	Standards Update	WPS
09/20	Standards Update	CA

PAVEMENT RESTORATION



DRAWN: C. ALBARDA	DATE: SEPTEMBER 3, 2020
CHECKED: B HANSEN	SCALE: NOT TO SCALE
APPROVED: L. KRUSZEWSKI	DRAWING No.: GL-04

CONIFEROUS
LESS THAN 3.0m HEIGHT

DECIDUOUS
LESS THAN 100mm CAL.

NOTES:

1. IF MINIMUM UTILITY SETBACKS PERMIT, POSITION TREE STAKES INTO DIRECTION OF PREVAILING WINDS (N.W. & S.E.)
2. ALL TREE STAKES TO MAINTAIN 1.0m FROM ALL U.G. POWER, TELEPHONE AND GAS ALIGNMENTS
3. DIG ALL ROOT HOLES BY HAND WHEN CLOSER THAN 1.0m TO U.G. POWER, TELEPHONE AND GAS ALIGNMENTS

RUBBER BLACK HOSE—12mm OR APPROVED EQUAL, POSITION ABOVE FIRST STRONG BRANCHES OF DECIDUOUS TREE AND APPROX. 3/5 HEIGHT FOR CONIFEROUS TREE.

GALVANIZED GUY WIRE No. 12 MIN. LEAVE ENOUGH FLEXIBILITY IN WIRE TO ALLOW SLIGHT MOVEMENT OF TREE

2 STAKES PER TREE, POSITIONED NORTHWEST AND SOUTHEAST OF TREE. ALL EXPOSED PORTIONS OF STAKES MUST BE FREE OF RUST, SCALED, PRIMED AND PAINTED. TREE STAKES MIN. 2.0m LENGTH METAL T-BAR.

100mm MIN. DEPTH CONIFEROUS WOOD CHIP MULCH OVER EXPOSED ROOT BALL AND PULLED BACK 150mm FROM TRUNK. MULCH MUST BE COMMERCIALY AVAILABLE FROM DISEASE-FREE STOCK.

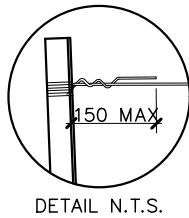

TOP 300mm ALL TREE STAKES PAINTED TO MATCH ANNUAL COLOR CODES.

- 2020 - GREEN
- 2021 - WHITE
- 2022 - YELLOW
- 2023 - GREEN
- 2024 - BLUE
- 2025 - WHITE
- 2026 - YELLOW
- 2027 - GREEN
- 2028 - BLUE
- 2029 - WHITE
- 2030 - YELLOW

UNDISTURBED NATIVE SUBSOIL

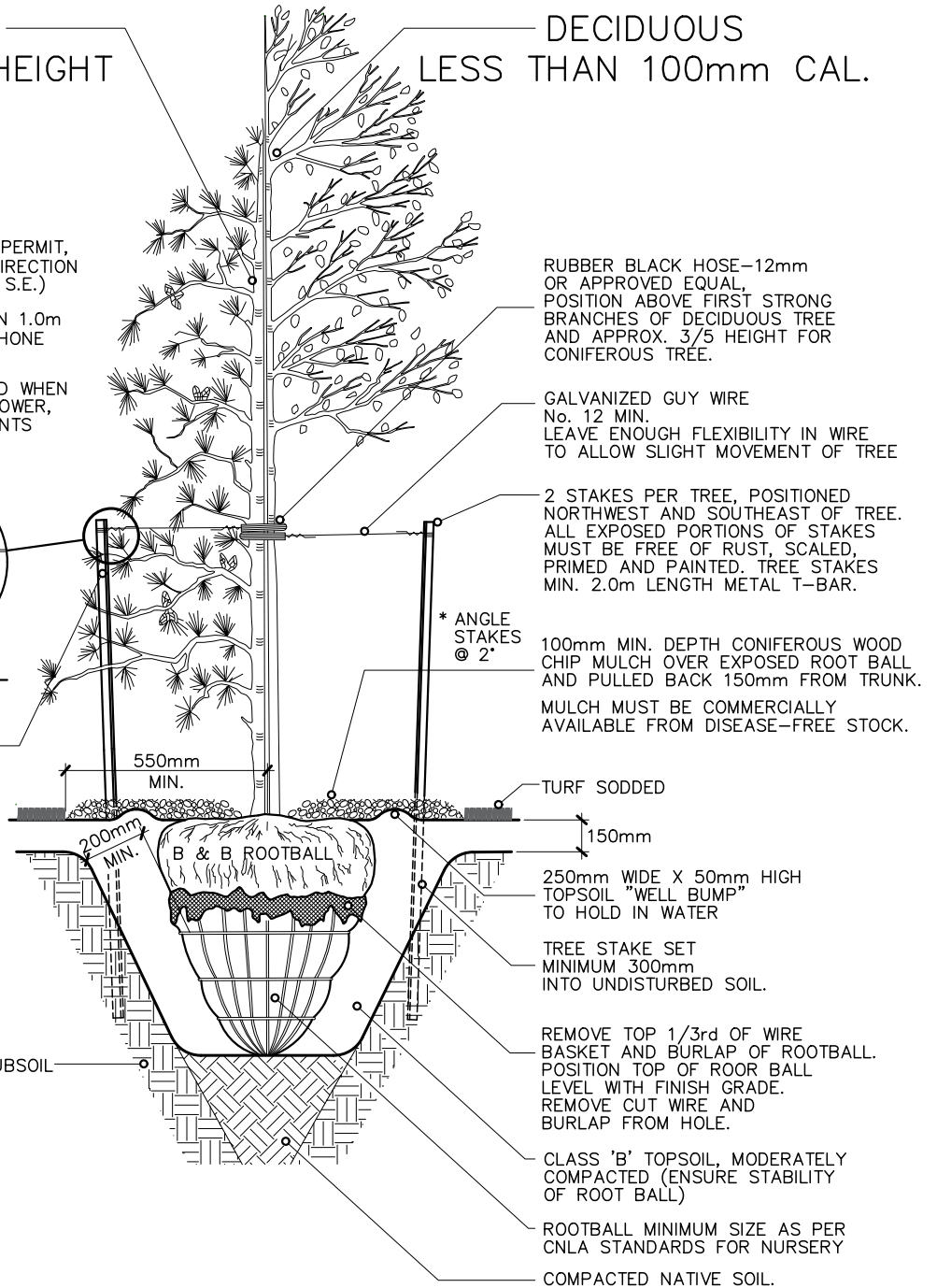

250mm WIDE X 50mm HIGH TOPSOIL "WELL BUMP" TO HOLD IN WATER

TREE STAKE SET MINIMUM 300mm INTO UNDISTURBED SOIL.

REMOVE TOP 1/3rd OF WIRE BASKET AND BURLAP OF ROOTBALL. POSITION TOP OF ROOT BALL LEVEL WITH FINISH GRADE. REMOVE CUT WIRE AND BURLAP FROM HOLE.

CLASS 'B' TOPSOIL, MODERATELY COMPACTED (ENSURE STABILITY OF ROOT BALL)

ROOTBALL MINIMUM SIZE AS PER CNLA STANDARDS FOR NURSERY

COMPACTED NATIVE SOIL.

THE CITY OF
SPRUCE GROVE

PLANNING AND INFRASTRUCTURE

TREE PLANTING

REVISIONS		
DATE	DETAILS	DRAWN



DRAWN: A. STACHNIAK	DATE: JANUARY 19, 2021
CHECKED: M. HUSSEY	SCALE: NOT TO SCALE
APPROVED: M. HUSSEY	DRAWING No.: LG-01

NOTES:

1. PRUNE ONLY DEAD, BROKEN, OR DISEASED BRANCHES TO MAINTAIN PROPER SHRUB FORM. DECIDUOUS ONLY.
2. DO NOT ROTOTILL WITHIN 1.0m OF U.G. POWER, TELEPHONE AND GAS ALIGNMENTS.
3. DIG ALL ROOT HOLES BY HAND WHEN CLOSER THAN 1.0m OF U/G SHALLOW UTILITIES
4. ALL DIMENSIONS ARE IN MILLIMETRES UNLESS NOTED OTHERWISE.

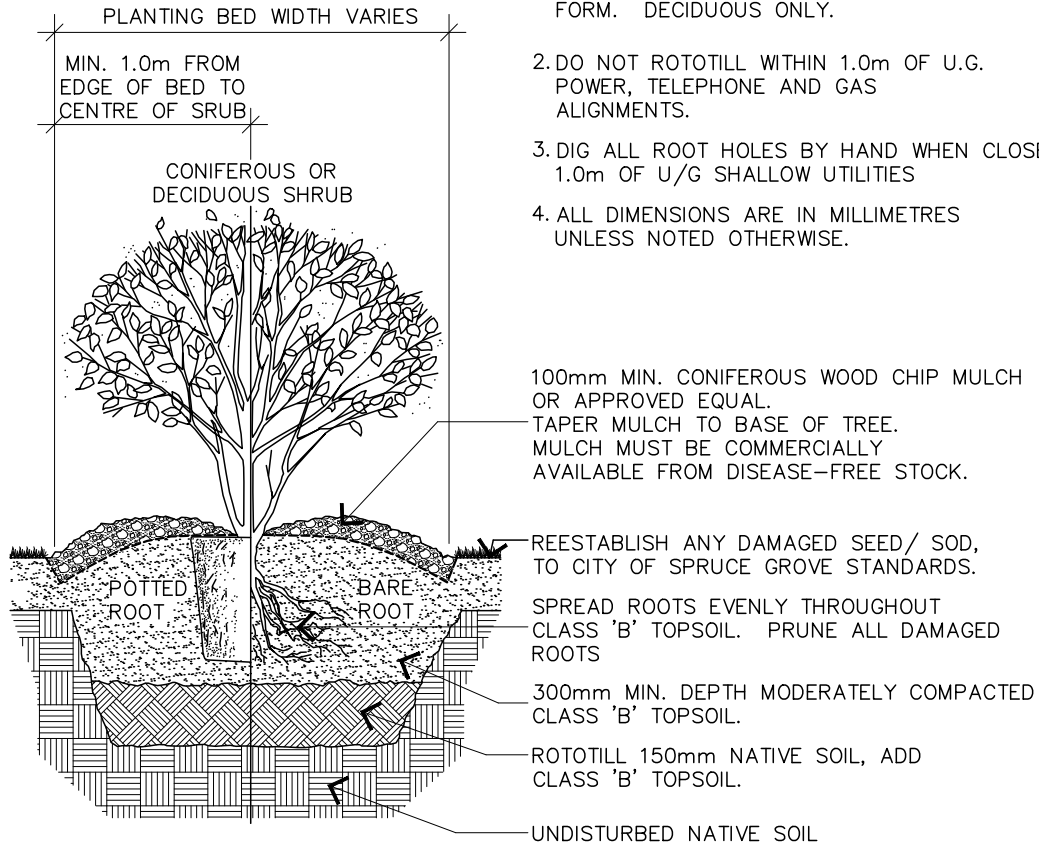

THE CITY OF
SPRUCE GROVE

PLANNING AND INFRASTRUCTURE

REVISIONS			SHRUB PLANTING		
DATE	DETAILS	DRAWN			
				DRAWN: A. STACHNIAK	DATE: FEBRUARY 19, 2020
				CHECKED: M. HUSSEY	SCALE: NOT TO SCALE
				APPROVED: M. HUSSEY	DRAWING No.: LG-02

TYPICAL SECTION

300 x 300 x 3000 P.T.
 TIMBER POST
 CHAMFER TOP
 50 DEEP REVEAL
 HGP LOGO TO BE ALUMINUM
 BACKED LOGO ON 2 SIDES
 TREAT ALL CUTS WITH
 TWO COATS GREEN PENTOX
 TWO COATS OLYMPIC
 SEMI-TRANS. STAIN CEDAR

LOGOS, LETTERS & ARROWS
 TO BE ALUMINUM BACKED
 REFLECTIVE DECALS
 AND TO BE RECESSED INTO
 POST FLUSH WITH FACE
 SIGNS TO BE SECURED TO
 POST WITH TAMPER-PROOF
 STAINLESS STEEL SCREWS
 CONSISTENT WITH EXISTING
 CITY STANDARD

PLOT HOLE TO BE
 BACKFILLED WITH COMPACTED
 20mm CRUSHED GRAVEL

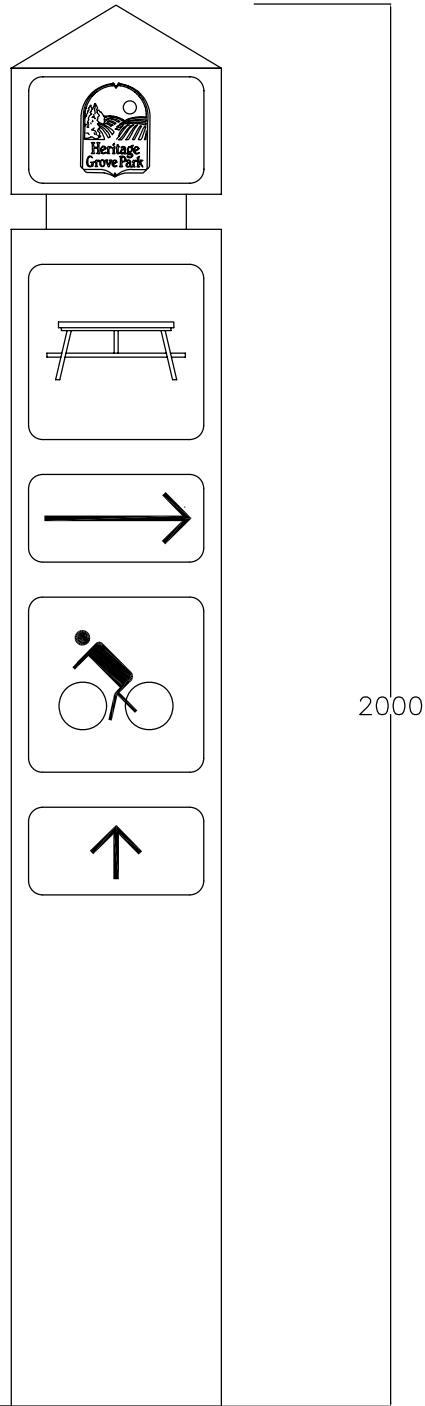

XREFS

C:\DETAILS\SHEET2-TK

THE CITY OF
 SPRUCE GROVE

PLANNING AND INFRASTRUCTURE

REVISIONS			TRAIL SIGN POST		
DATE	DETAILS	DRAWN			
				DRAWN: T. CRAWFORD	DATE: MARCH 6, 2006
				CHECKED: J. MUSTARD	SCALE: NOT TO SCALE
				APPROVED: J. MUSTARD	DRAWING No.: LG-03

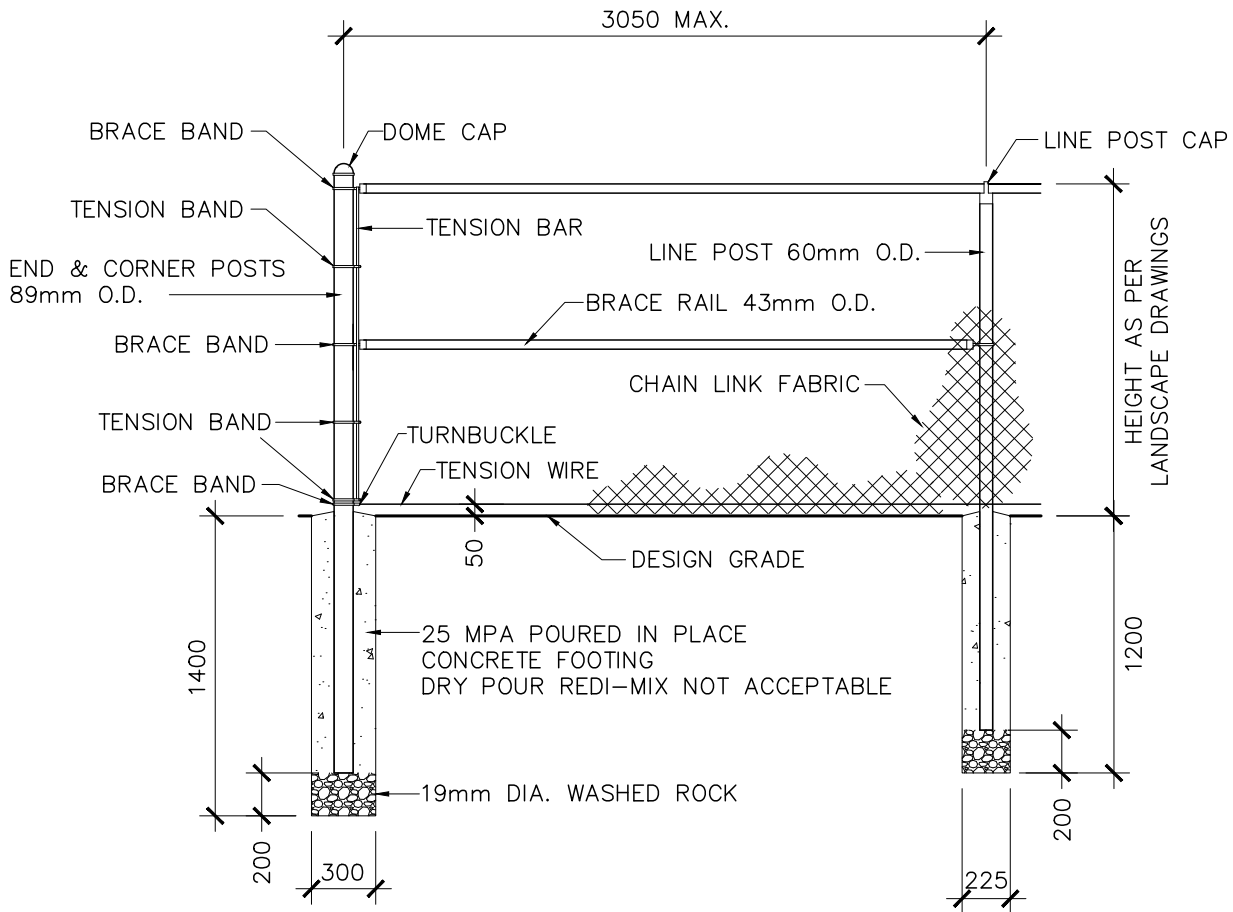

NOTES:

1. NO PORTION OF DEVELOPER FENCE MAY INCLUDE GATES OR PROVISIONS FOR FUTURE GATES UNLESS APPROVED BY THE CITY OF SPRUCE GROVE
2. FENCE MUST BE INSTALLED ENTIRELY WITHIN PRIVATE PROPERTY
3. NO PORTION OF FENCE MAY ENCROACH UTILITY EASEMENTS OR RIGHTS-OF-WAY
4. ALL PIPE SCHEDULE 40 HOT DIPPED GALVANIZED
5. ALL FASTENINGS, WIRE & HARDWARE GALVANIZED STEEL
6. MIDDLE BRACE RAIL REQUIRED AT ALL END SECTIONS
7. TIE-WIRES TO BE SPACED 300 O.C (FOR FABRIC TO LINE POSTS, RAILS & TENSION WIRE)
8. TENSION BANDS TO BE SPACED AT MINIMUM 300 O.C.

**THE CITY OF
SPRUCE GROVE**

PLANNING AND INFRASTRUCTURE

REVISIONS		
DATE	DETAILS	DRAWN

CHAIN LINK FENCE		
	DRAWN: A. STACHNIAK	DATE: FEBRUARY 13, 2020
	CHECKED: M. HUSSEY	SCALE: NOT TO SCALE
	APPROVED: M. HUSSEY	DRAWING No.: LG-04

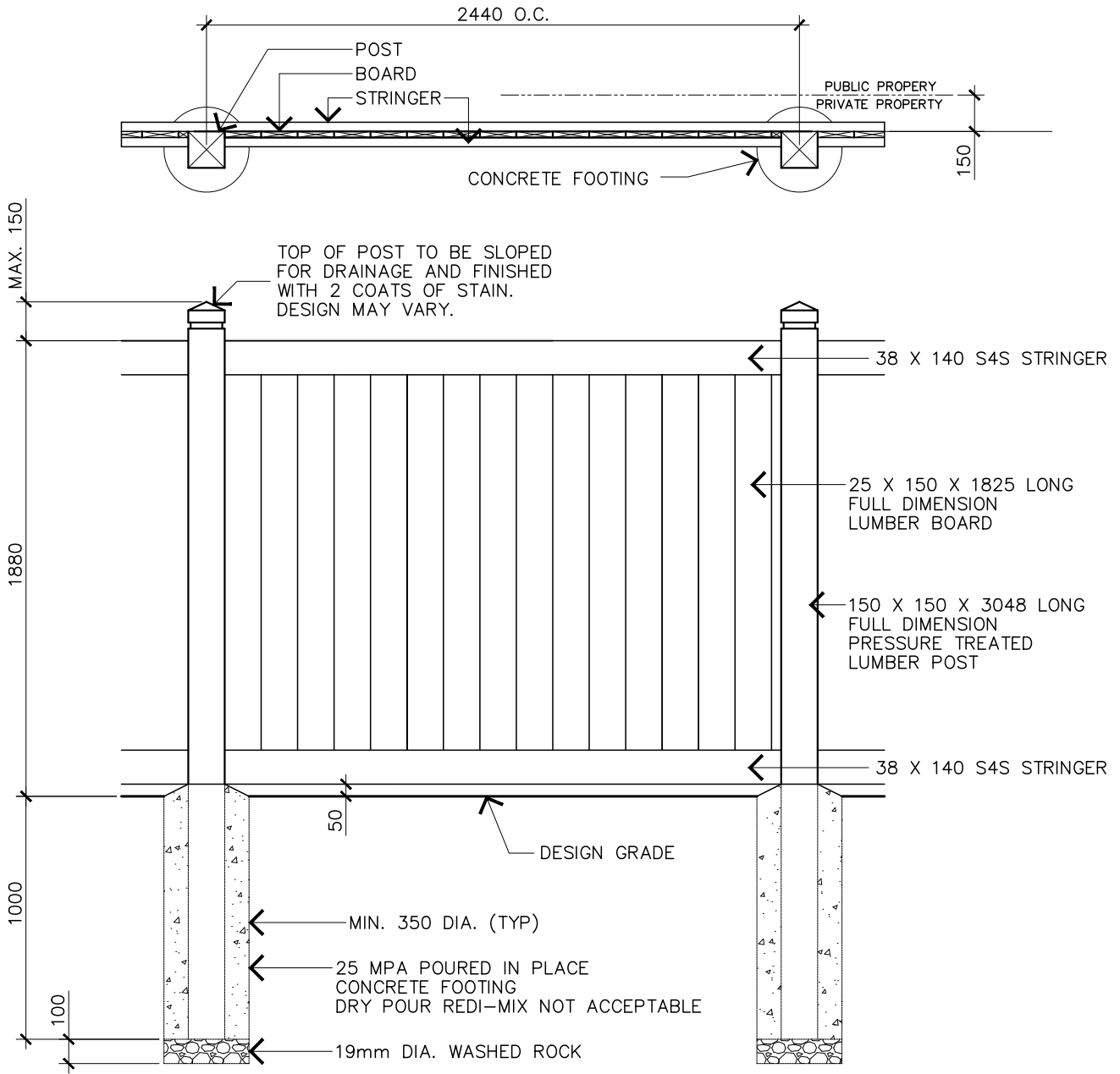

NOTES:

1. NO PORTION OF FENCE MAY ENCROACH UTILITY EASEMENTS OR RIGHTS-OF-WAY
2. ALL LUMBER TO RECEIVE 2 COATS OF STAIN.
3. BOARDS TO BE NAILED TO STRINGERS WITH GALVANIZED ARDOX NAILS MIN. 57 LONG, 3 PER BOARD PER STRINGER
4. MID-STRINGER OPTIONAL

THE CITY OF
SPRUCE GROVE

PLANNING AND INFRASTRUCTURE

REVISIONS		
DATE	DETAILS	DRAWN

TYPICAL WOOD SCREEN FENCE

DRAWN: A. STACHNIAK DATE: FEBRUARY 18, 2020

CHECKED: M. HUSSEY SCALE: NOT TO SCALE

APPROVED: M. HUSSEY DRAWING No.: LG-05

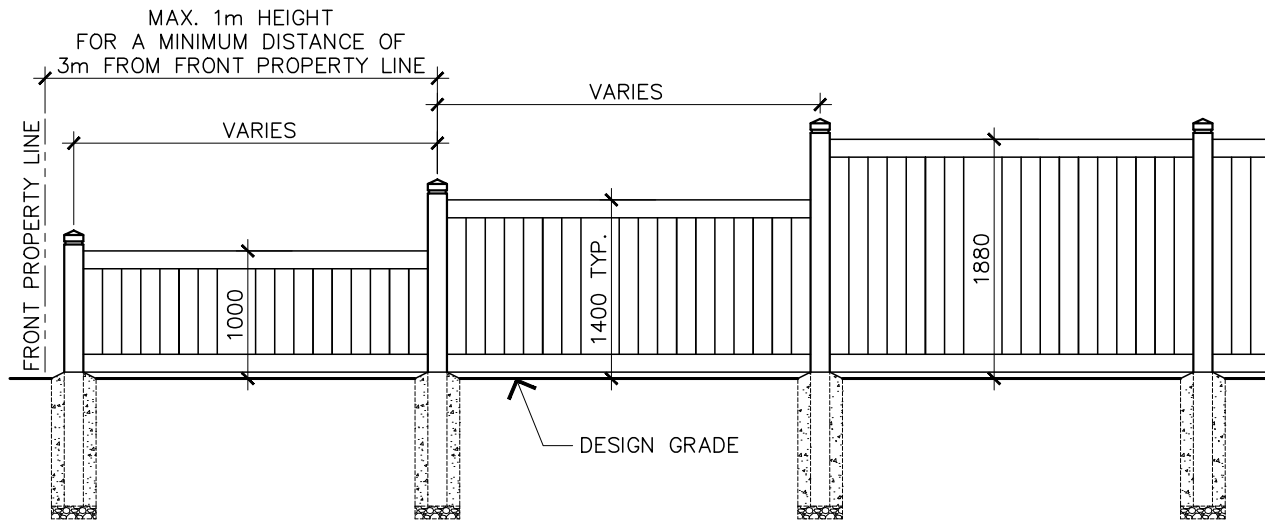

CORNER LOT WOOD FENCE STEP-DOWN DETAIL

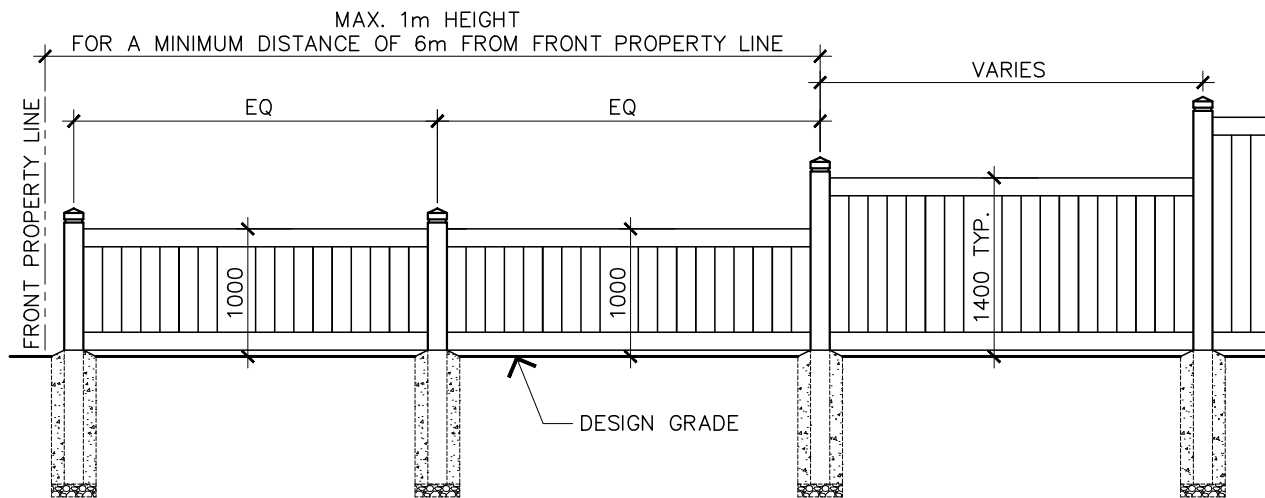

P.U.L. WOOD FENCE STEP-DOWN DETAIL

NOTES:

1. NO PORTION OF FENCE MAY ENCROACH UTILITY EASEMENTS OR RIGHTS-OF-WAY
2. FENCE MUST BE INSTALLED ENTIRELY WITHIN PRIVATE PROPERTY
3. SEE DETAIL LG-05 FOR SPECIFICATIONS ON FENCE MATERIALS, CONCRETE FOOTINGS, AND REQUIRED CLEARANCES

THE CITY OF
SPRUCE GROVE

PLANNING AND INFRASTRUCTURE

REVISIONS		
DATE	DETAILS	DRAWN

WOOD FENCE STEP-DOWN



DRAWN: A. STACHNIAK	DATE: FEBRUARY 12, 2020
CHECKED: M. HUSSEY	SCALE: NOT TO SCALE
APPROVED: M. HUSSEY	DRAWING No.: LG-06

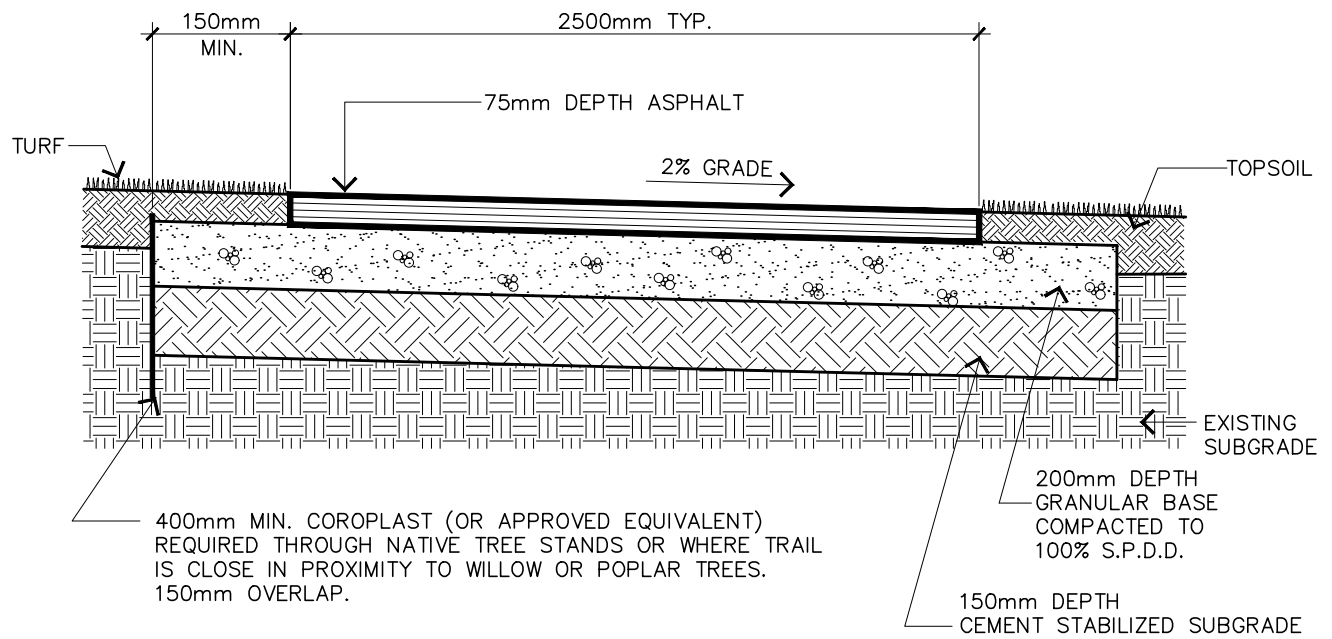

STANDARD ASPHALT TRAIL CROSS-SECTION

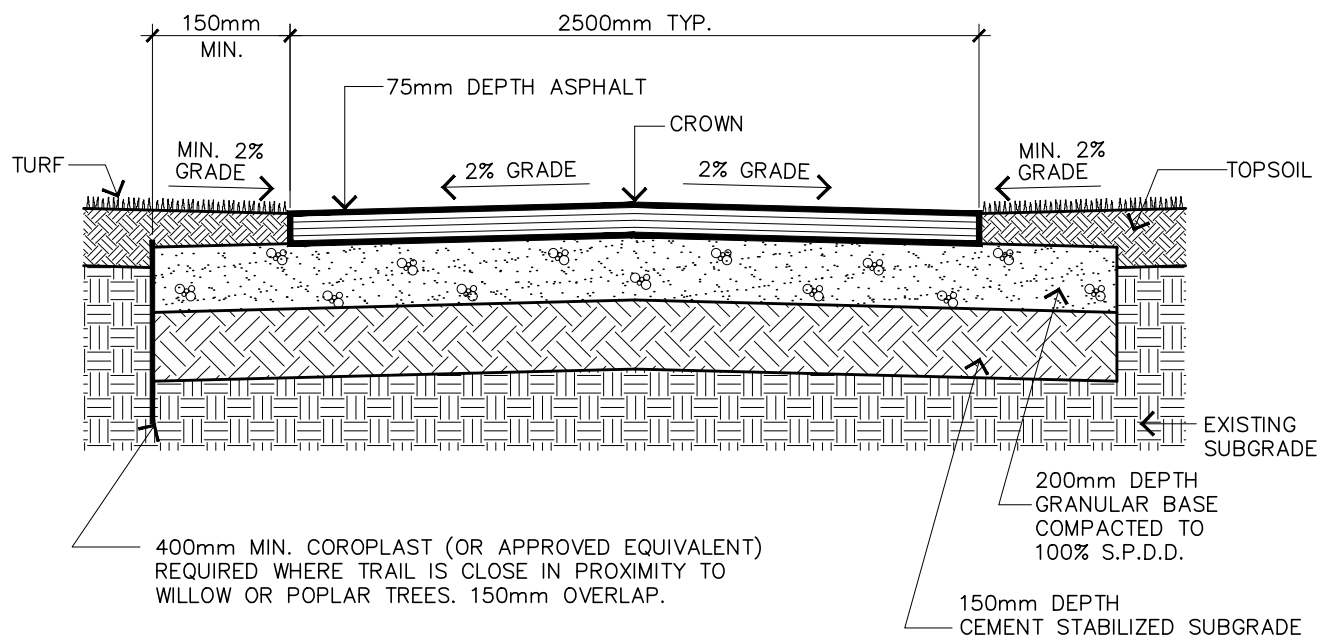

P.U.L. ASPHALT TRAIL CROSS-SECTION

NOTE:

CONTRACTOR IS RESPONSIBLE TO REHABILITATE ALL DISTURBED AREAS ALONG TRAIL EDGE WITH TOPSOIL AND SOD

THE CITY OF
SPRUCE GROVE

PLANNING AND INFRASTRUCTURE

REVISIONS

DATE	DETAILS	DRAWN
12/23	GBC compaction update	JC

ASPHALT TRAIL



DRAWN: A. STACHNIAK	DATE: JANUARY 13, 2021
CHECKED: M. HUSSEY	SCALE: NOT TO SCALE
APPROVED: M. HUSSEY	DRAWING No.: LG-07

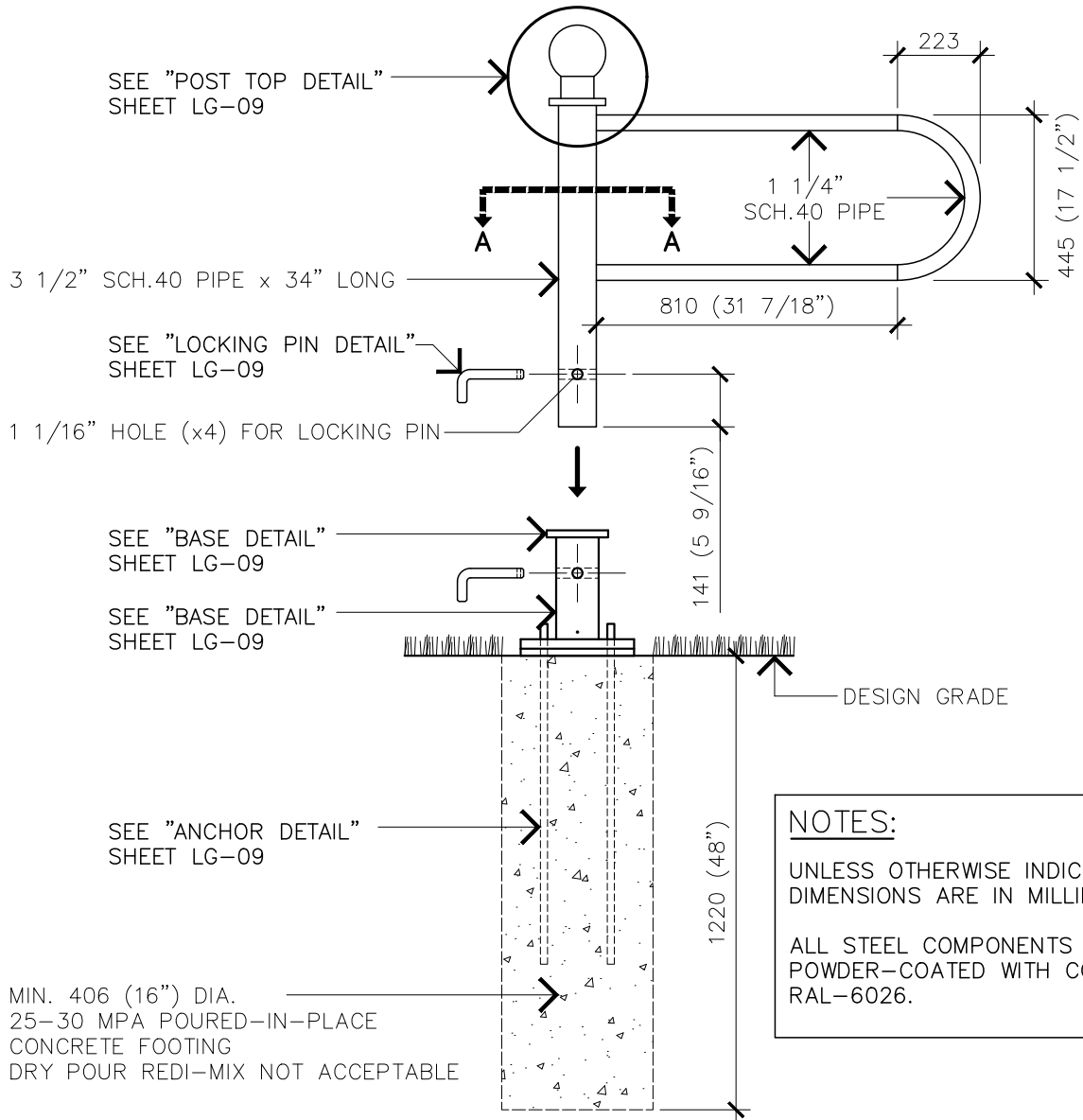
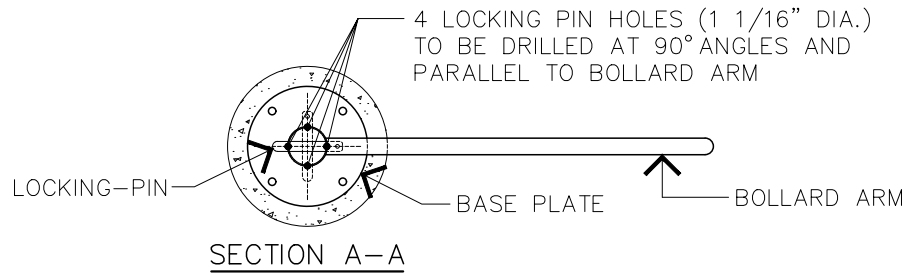

NOTES:
 UNLESS OTHERWISE INDICATED, ALL DIMENSIONS ARE IN MILLIMETRES
 ALL STEEL COMPONENTS TO BE POWDER-COATED WITH COLOUR RAL-6026.

ELEVATION VIEW

THE CITY OF
 SPRUCE GROVE

PLANNING AND INFRASTRUCTURE

REVISIONS		
DATE	DETAILS	DRAWN

"P" SWING GATE BOLLARD		
	DRAWN: A. STACHNIAK	DATE: MARCH 23, 2020
	CHECKED: M. HUSSEY	SCALE: NOT TO SCALE
	APPROVED: M. HUSSEY	DRAWING No.: LG-08

NOTES:

UNLESS OTHERWISE INDICATED, ALL DIMENSIONS ARE IN MILLIMETRES

ALL STEEL COMPONENTS TO BE POWDER COATED WITH COLOUR RAL-6026.

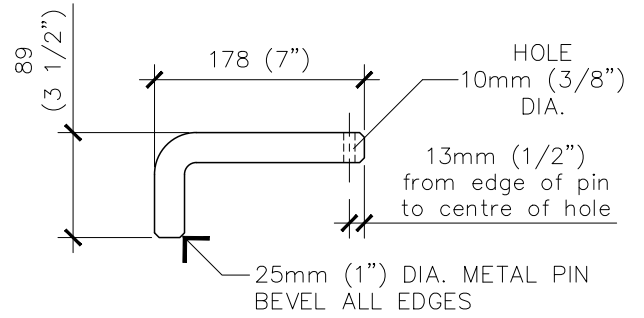

LOCKING PIN DETAIL

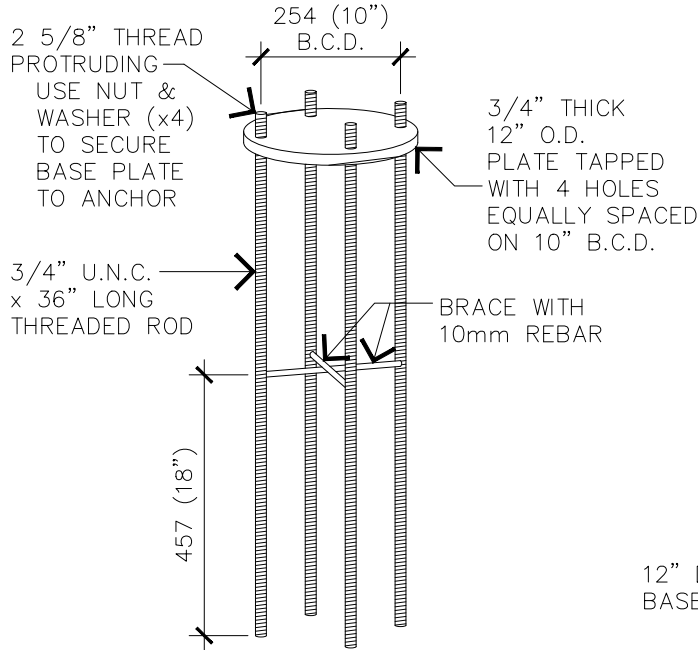

ANCHOR DETAIL

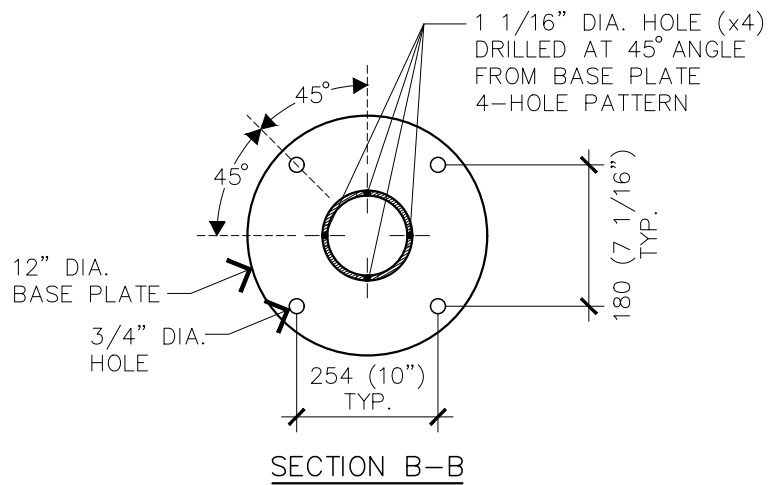

SECTION B-B

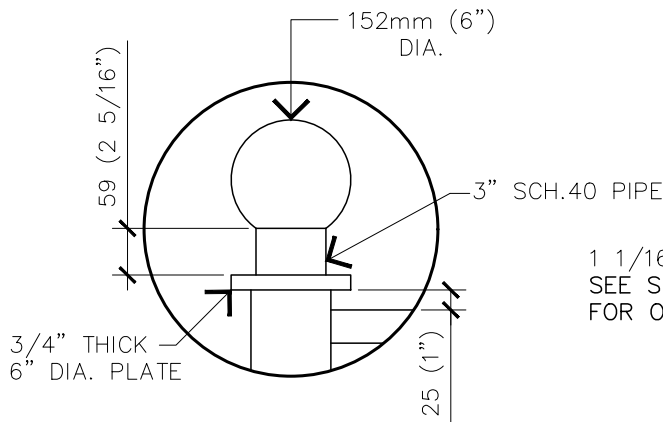

POST TOP DETAIL

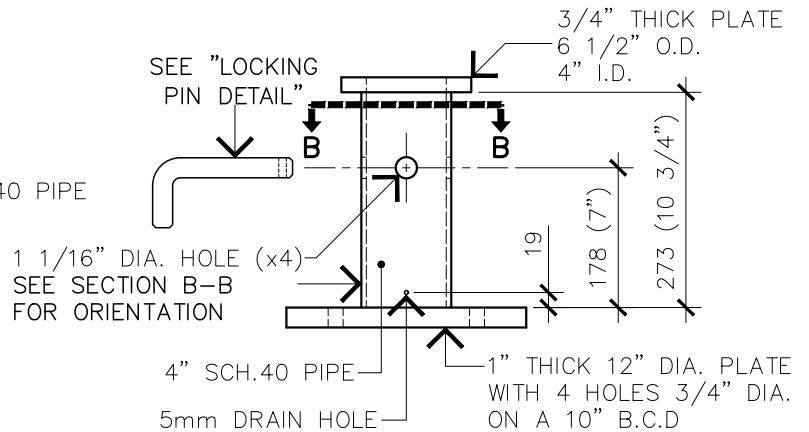

BASE DETAIL

THE CITY OF
SPRUCE GROVE

PLANNING AND INFRASTRUCTURE

REVISIONS		
DATE	DETAILS	DRAWN

"P" SWING GATE BOLLARD		
	DRAWN: A. STACHNIAK	DATE: MARCH 23, 2020
	CHECKED: M. HUSSEY	SCALE: NOT TO SCALE
	APPROVED: M. HUSSEY	DRAWING No.: LG-09

NOTES:

ALL DIMENSIONS ARE IN MILLIMETRES

A FIXED BOLLARD IS REQUIRED TO BE INSTALLED WHERE DISTANCE BETWEEN P-GATE BOLLARD AND ADJACENT FENCE EXCEEDS 1.5m.

DISTANCE BETWEEN FIXED BOLLARD AND P-GATE BOLLARD MAY NOT EXCEED 1.5m.

NO PORTION OF BOLLARD MAY ENCROACH UTILITY EASEMENTS OR RIGHTS-OF-WAY

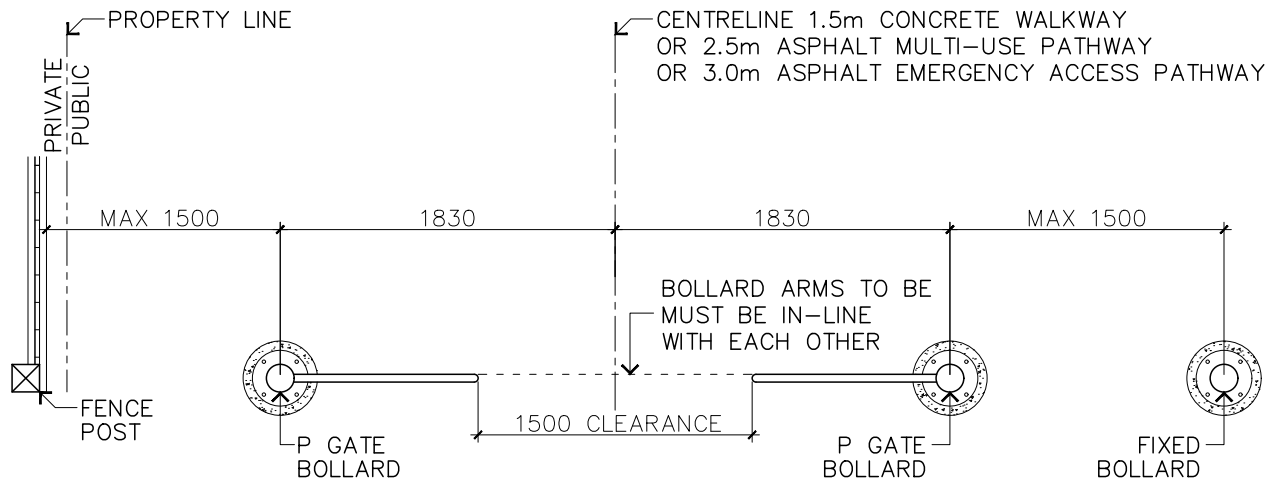

PLAN VIEW

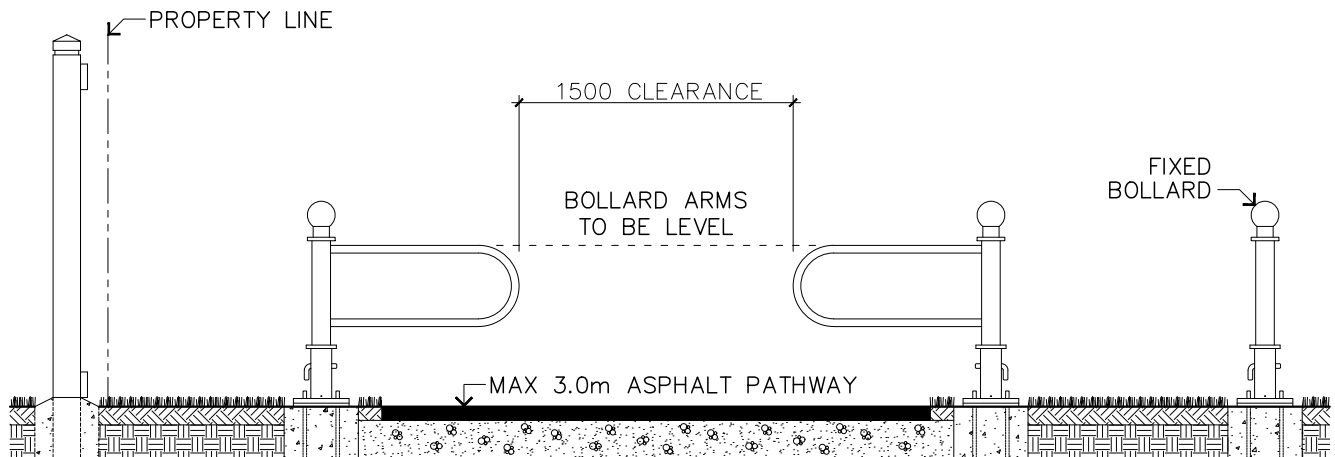

ELEVATION VIEW

THE CITY OF
SPRUCE GROVE

PLANNING AND INFRASTRUCTURE

REVISIONS		
DATE	DETAILS	DRAWN

P-GATE BOLLARD INSTALLATION

	DRAWN: A. STACHNIAK	DATE: MAY 27, 2020
	CHECKED: M. HUSSEY	SCALE: NOT TO SCALE
	APPROVED: M. HUSSEY	DRAWING No.: LG-10

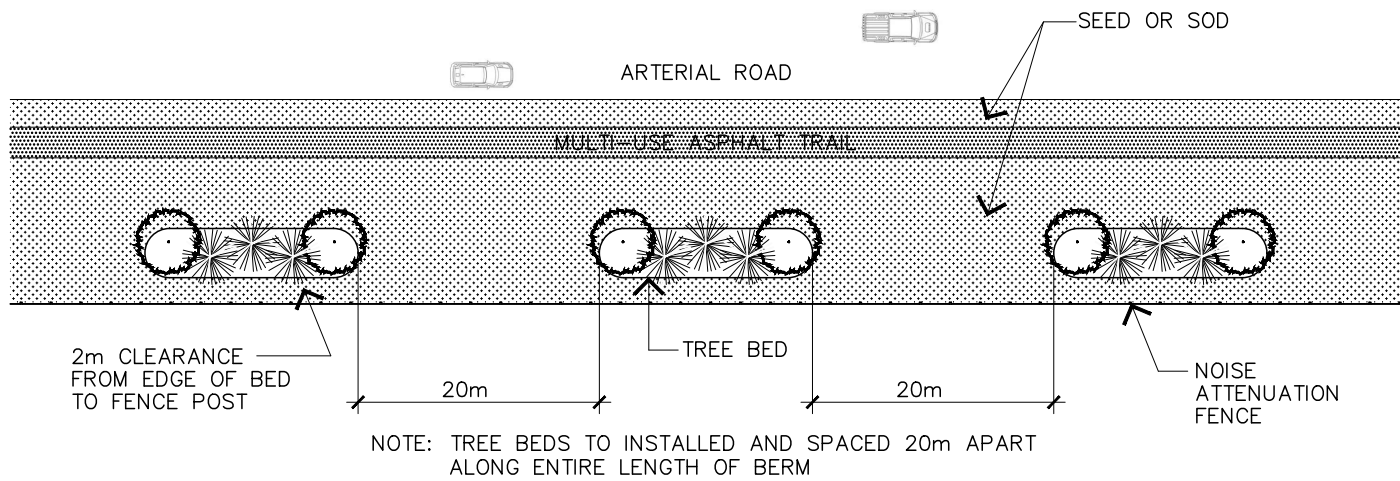

ARTERIAL BERM LANDSCAPE PLAN

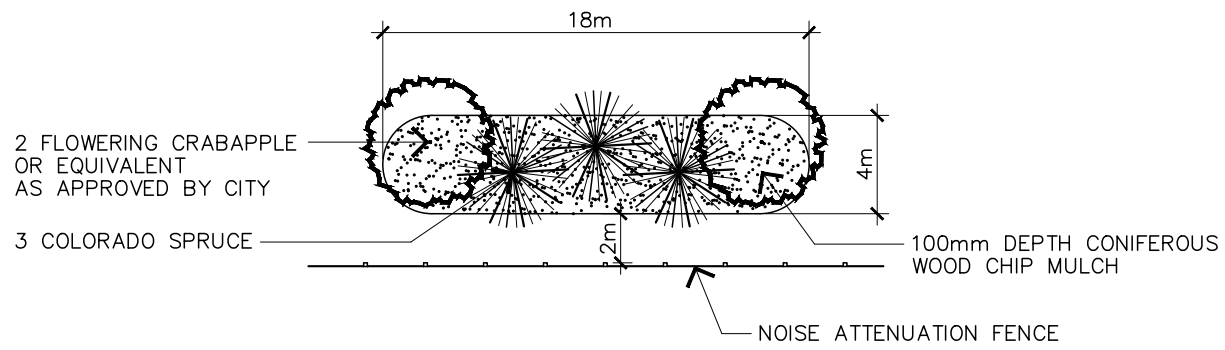

TREE BED LAYOUT

NOTES:

1. PLANT TREES AS PER DETAIL LG-01 OF THE CITY OF SPRUCE GROVE'S MUNICIPAL DEVELOPMENT STANDARDS IN ITS LATEST EDITION.
2. EDGES OF TREE BEDS SHALL BE CUT. DO NOT USE LANDSCAPE EDGER.
3. MULCH MUST BE COMMERCIALY AVAILABLE FROM DISEASE-FREE STOCK.
4. TOPSOIL, SEED AND SOD SHALL CONFORM TO "SECTION IX-LANDSCAPING" OF THE CITY OF SPRUCE GROVE'S MUNICIPAL DEVELOPMENT STANDARDS IN ITS LATEST EDITION.

THE CITY OF
SPRUCE GROVE

PLANNING AND INFRASTRUCTURE

REVISIONS		
DATE	DETAILS	DRAWN

ARTERIAL BERM LANDSCAPING



DRAWN: A. STACHNIAK	DATE: FEBRUARY 19, 2021
CHECKED: M. HUSSEY	SCALE: NOT TO SCALE
APPROVED: M. HUSSEY	DRAWING No.: LG-11

CAP END OF SANITARY (RED PLUG) AND STORM (GREEN PLUG)

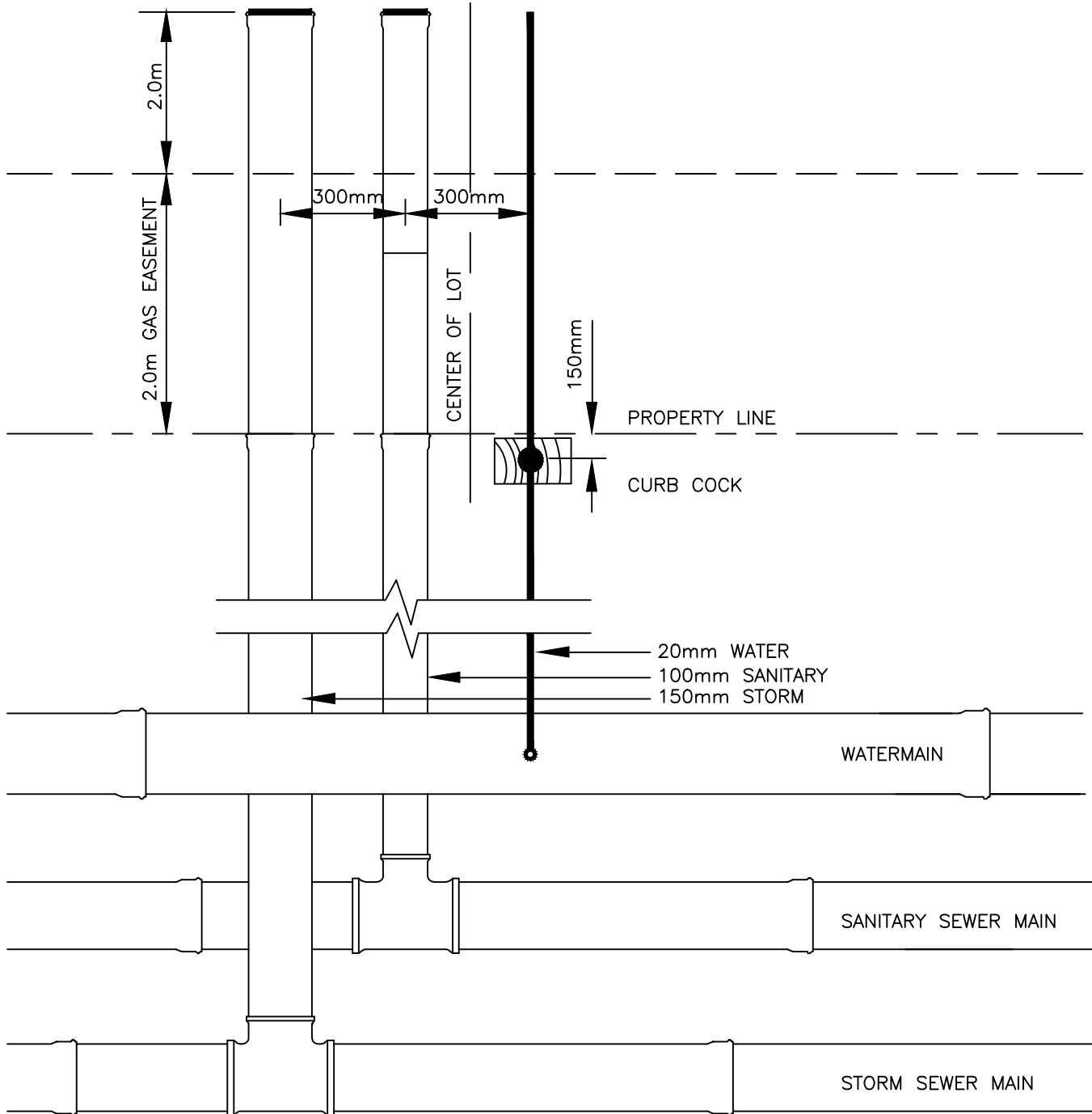

NOTES:

- THE CITY ACCEPTS NO RESPONSIBILITY FOR THE CONSTRUCTION OR MAINTENANCE OF THE SERVICES BEYOND PROPERTY LINE
- THE END OF THE WATER SERVICE SHOULD BE CLOSED WITH A PERMEABLE FILTER CLOTH TO PREVENT INTRUSION OF DEBRIS AND TO ALLOW TESTING FLOW OF CURBSTOP.
- MARK CURB COCK WITH A 50x100x750mm STAKE PAINTED RED.
- STORM SERVICE FOR FOUNDATION DRAINS REQUIRED ON ALL NEW DEVELOPMENTS.

THE CITY OF
SPRUCE GROVE

PLANNING AND INFRASTRUCTURE

REVISIONS

DATE	DETAILS	DRAWN
4/12	Add'n of Plug Colors	RP
4/12	Rev. Extension into PL	RP
4/19	Standards Update	WPS
2/22	Standards Update	

SINGLE SERVICE DETAIL



DRAWN: T. CRAWFORD	DATE: FEBRUARY 10, 2022
CHECKED: J. MUSTARD	SCALE: NOT TO SCALE
APPROVED: J. MUSTARD	DRAWING No.: SE-01

CAP END OF SANITARY (RED PLUG) AND STORM (GREEN PLUG)

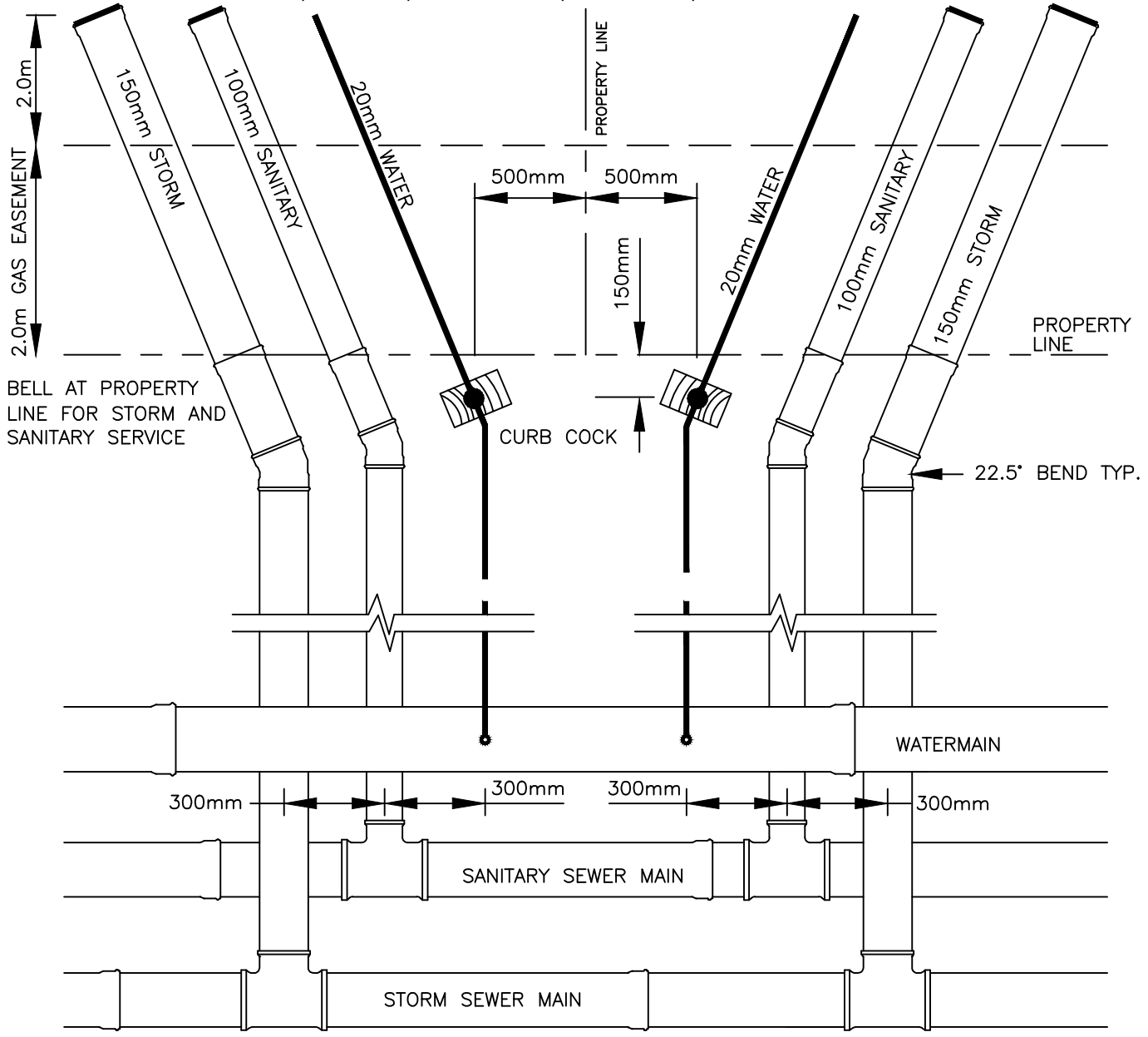

NOTES:

- THE CITY ACCEPTS NO RESPONSIBILITY FOR THE CONSTRUCTION OR MAINTENANCE OF THE SERVICES BEYOND PROPERTY LINE
- THE END OF THE WATER SERVICE SHOULD BE CLOSED WITH A PERMEABLE FILTER CLOTH TO PREVENT INTRUSION OF DEBRIS AND TO ALLOW TESTING FLOW OF CURBSTOP.
- STORM SERVICE FOR FOUNDATION DRAINS REQUIRED ON ALL NEW DEVELOPMENTS.

THE CITY OF
SPRUCE GROVE

PLANNING AND INFRASTRUCTURE

REVISIONS

DATE	DETAILS	DRAWN
4/12	Rev. Distance from PL	RP
4/12	Rev. Extension into PL	RP
4/19	Standards Update	WPS
2/22	Standards Update	

DOUBLE SERVICE DETAIL



DRAWN: T. CRAWFORD	DATE: FEBRUARY 10, 2022
CHECKED: J. MUSTARD	SCALE: NOT TO SCALE
APPROVED: J. MUSTARD	DRAWING No.: SE-02

NOTES:

1. FOR 25mm PIPE DIAMETERS—USE TYPE K COPPER PEX_a (CROSS LINKED POLYETHYLENE), PEX—AL—PEX OR ACCEPTED ALTERNATIVE.
2. FOR 50mm PIPE DIAMETERS—USE TYPE K COPPER PIPE OR ACCEPTED ALTERNATIVE.
3. PIPE CLAMP TO BE ALL BRASS OR ACCEPTED ALTERNATIVE
4. PEX_a PIPE REQUIRES 2" STAINLESS STEEL INSERTS BE PLACED ON BOTH SIDES OF THE "CC" CONNECTION
5. MAINSTOPS TAPS SHALL BE A MINIMUM OF 600MM APART AND NO LESS THAN 300MM TO A COUPLING OR COLLAR.
6. COPPER SERVICE SHALL BE ONE CONTINUOUS PIECE UNLESS LENGTH EXCEEDS 20M AND ONLY THEN WILL A DOUBLE UNION BE ALLOWED.
7. SERVICE CLAMPS REQUIRED WHERE MAIN STOP EXCEEDS 20MM FOR 150MM MAIN AND 25MM FOR 200MM—400MM MAINS.
8. SEWER SERVICE PIPE SHALL BE PVC PIPE, SDR 35, ASTM D3034, AND 100MM DIAMETER (MIN.) UNLESS OTHERWISE SPECIFIED.
9. INVERT ELEVATION AT PL SHALL BE MIN. 2.60M BELOW DESIGN FINISHED GRADE. USE DESIGN INVERT OF SERVICE WHERE INDICATED.

10. (A) SEWER SERVICES TO BE CONNECTED TO PVC MAIN WITH IN-LINE WYES OR TEE-WYES. (B) USE OTHER APPROVED CONNECTION TO OTHER THAN PVC PIPE.
11. ALL DIMENSIONS ARE IN MILLIMETERS UNLESS OTHERWISE INDICATED.

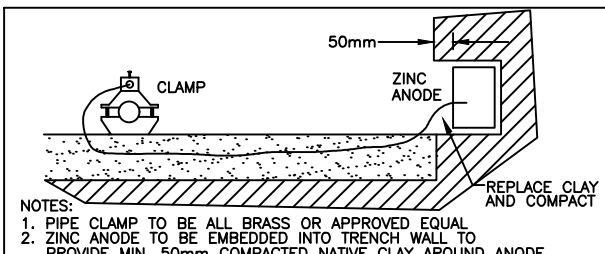

- NOTES:**
1. PIPE CLAMP TO BE ALL BRASS OR APPROVED EQUAL
 2. ZINC ANODE TO BE EMBEDDED INTO TRENCH WALL TO PROVIDE MIN. 50mm COMPACTED NATIVE CLAY AROUND ANODE

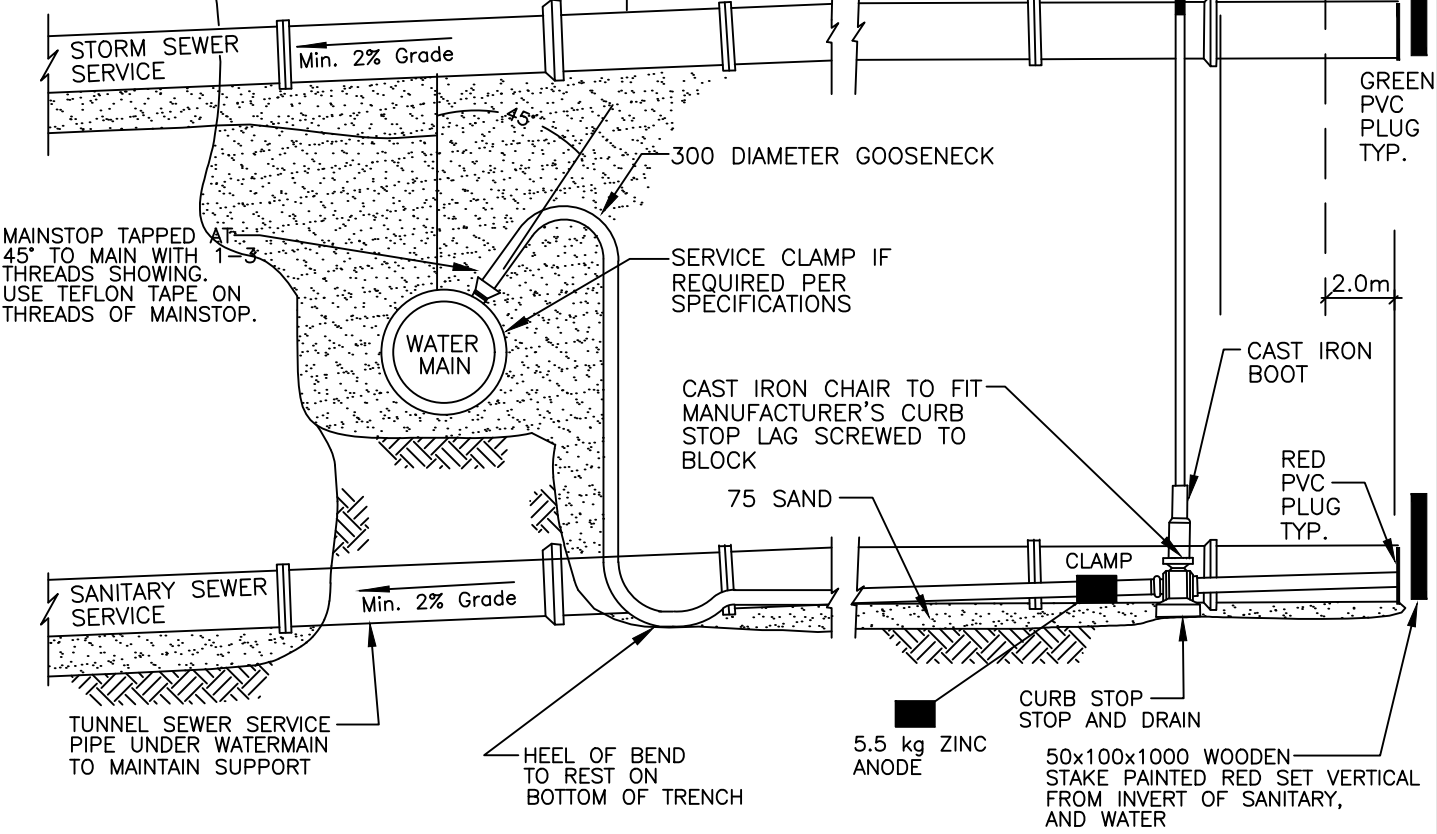

THE CITY OF SPRUCE GROVE PLANNING AND INFRASTRUCTURE

REVISIONS		
DATE	DETAILS	DRAWN
4/19	Standard Update	WPS
9/20	Standard Update	CA
2/22	Standard Update	

SERVICE CONNECTION DETAIL

	DRAWN: C. ALBARDA	DATE: FEBRUARY 10, 2022
	CHECKED: B. HANSEN	SCALE: NOT TO SCALE
	APPROVED: L. KRUSZEWSKI	DRAWING No.: SE-03

50x100 WOODEN STAKE
WITH EXPOSED PORTION
PAINTED RED.

NOTES:

1. SERVICE BOX TO BE EPOXY COATED WITH STAINLESS STEEL RODS.
2. ALL DIMENSIONS ARE IN MILLIMETERS UNLESS OTHERWISE INDICATED
3. SEE SECTION VI FOR MORE DETAILS.

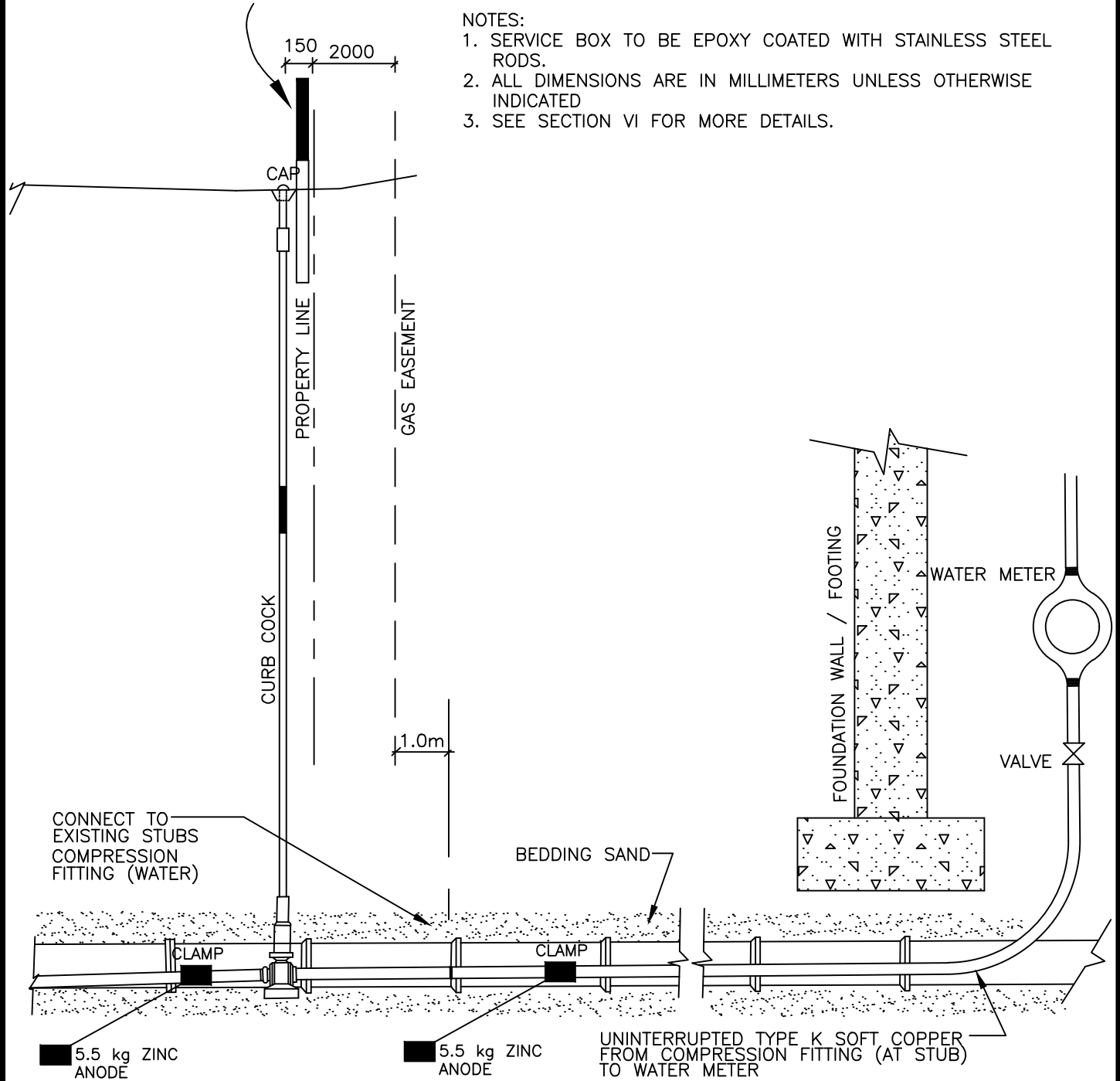

P:\Municipal Development Standards\2022 FULL MDS

THE CITY OF
SPRUCE GROVE

PLANNING AND INFRASTRUCTURE

REVISIONS

DATE	DETAILS	DRAWN
4/19	Standards Update	WPS
9/20	Standards Update	CA
2/22	Standards Update	

WATER AND SEWER TO HOUSE



DRAWN: C. ALBARDA	DATE: FEBRUARY 10, 2022
CHECKED: B. HANSEN	SCALE: NOT TO SCALE
APPROVED: L. KRUSZEWSKI	DRAWING No.: SE-04

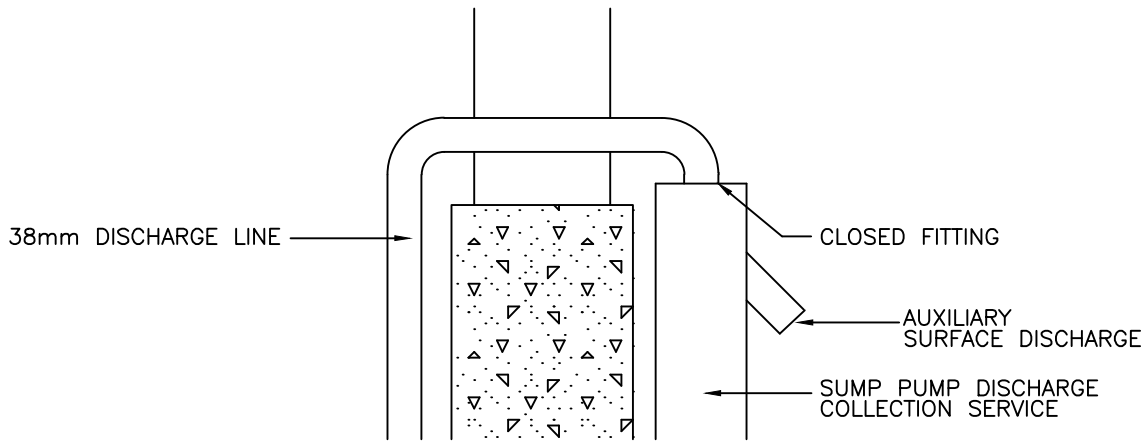

DETAIL A

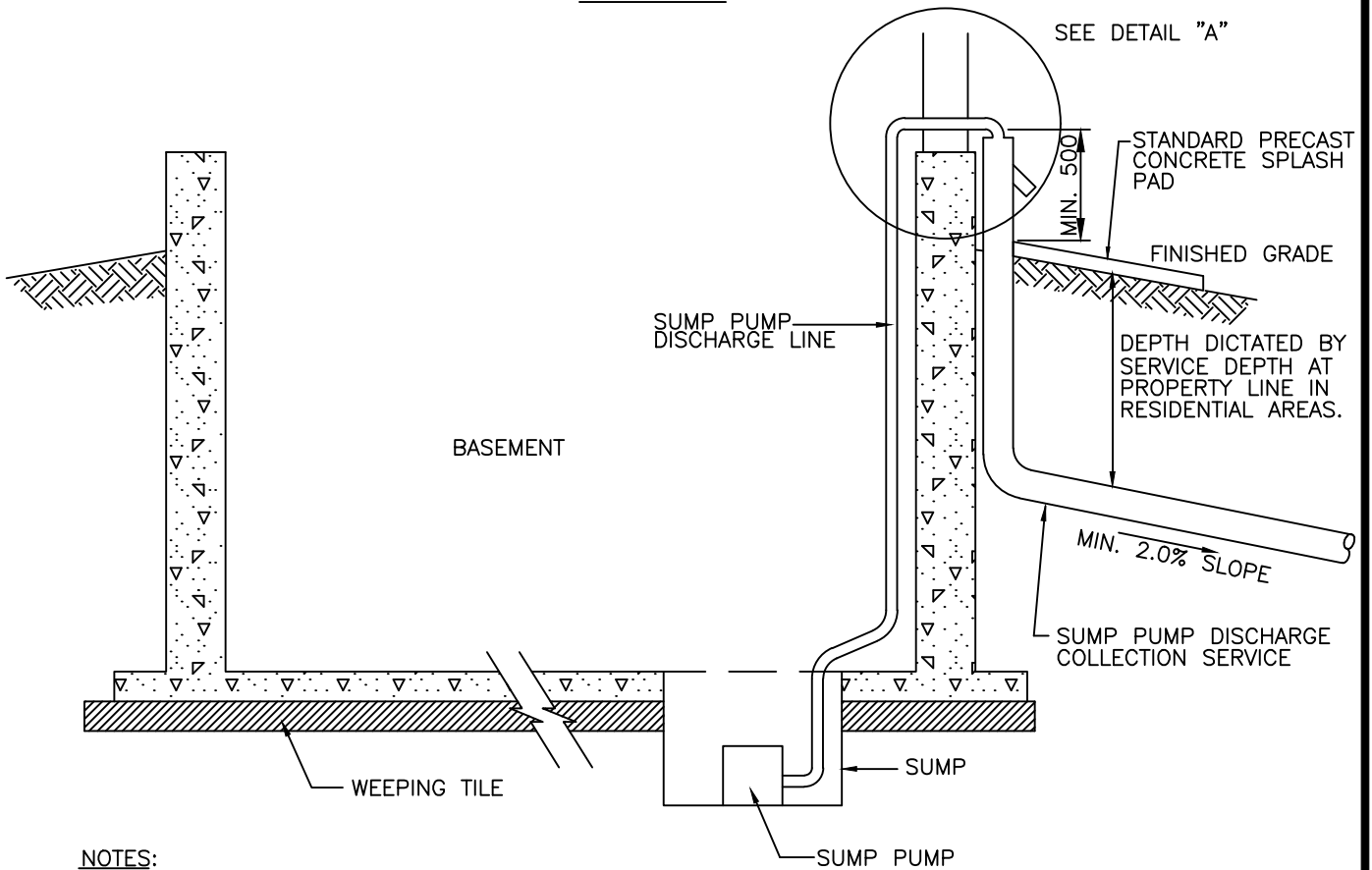

NOTES:

1. ROOF LEADERS (DOWNSPOUTS) OR ANY OTHER STORM WATER SOURCE MUST NOT BE CONNECTED TO THE SUMP DISCHARGE COLLECTION SERVICE LINE. UNLESS SPECIFICALLY REQUESTED BY THE CITY.
2. THE AUXILIARY SURFACE DISCHARGE MUST BE INSTALLED TO PROVIDE AN OVERFLOW IN THE EVENT THAT THE STORM DRAINAGE SYSTEM CANNOT ACCOMMODATE FLOWS DUE TO CAPACITY, FREEZING OR OTHER PROBLEMS.
3. SUMP PUMP BYPASS TO BE USED ONLY WHERE APPROVED BY THE CITY.
4. ALL DIMENSIONS ARE IN MILLIMETERS UNLESS OTHERWISE INDICATED.

THE CITY OF
SPRUCE GROVE

PLANNING AND INFRASTRUCTURE

REVISIONS

DATE	DETAILS	DRAWN
4/19	Standards Update	WPS
09/20	Standards Update	CA

SUMP PUMP CONNECTION



DRAWN: C. ALBARDA	DATE: SEPTEMBER 3, 2020
CHECKED: B HANSEN	SCALE: NOT TO SCALE
APPROVED: L. KRUSZEWSKI	DRAWING No.: SE-05

XREFS

C:\DETAILS\SHEET2-TK

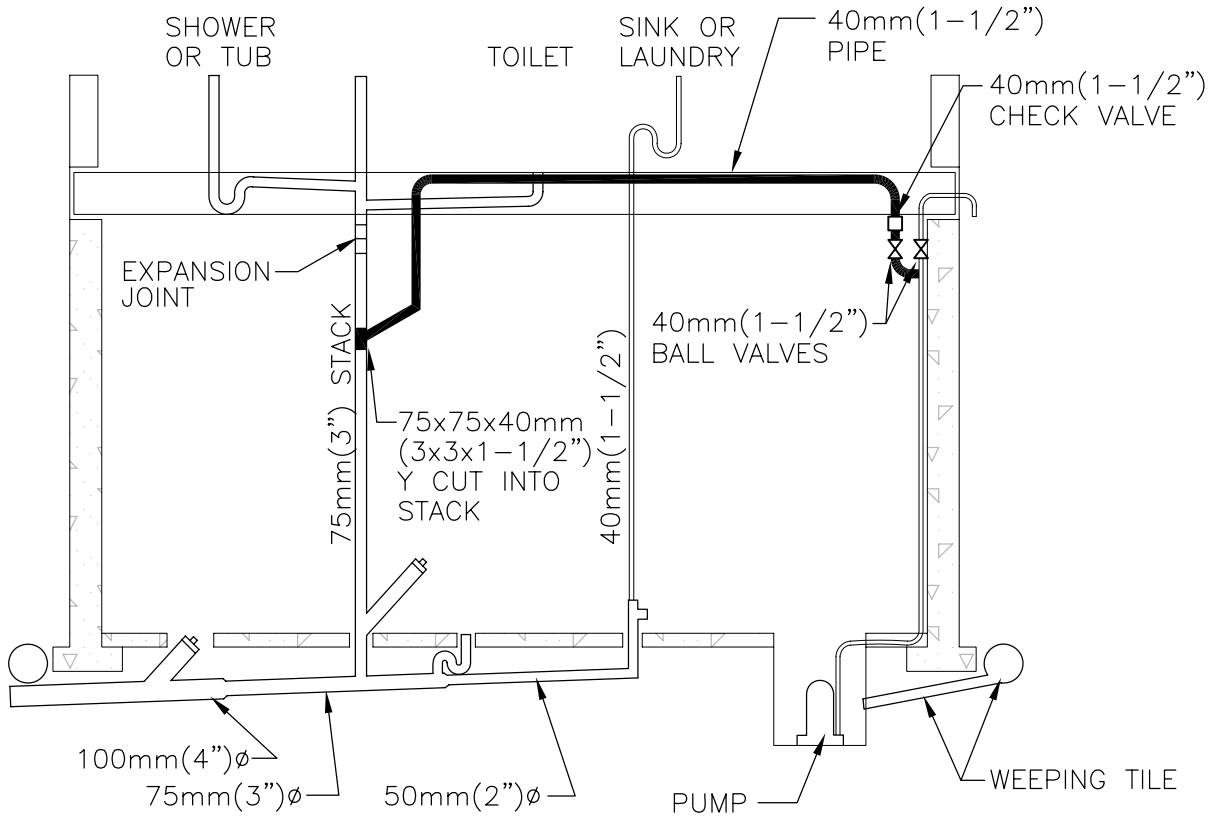

XREFS

THE CITY OF
SPRUCE GROVE

PLANNING AND INFRASTRUCTURE

C:\DETAILS\SHEET2-TK

REVISIONS			SUMP PUMP BYPASS – DUAL BALL VALVE		
DATE	DETAILS	DRAWN			
				DRAWN: T. CRAWFORD	DATE: MARCH 6, 2006
				CHECKED: J. MUSTARD	SCALE: NOT TO SCALE
				APPROVED: J. MUSTARD	DRAWING No.: SE-06

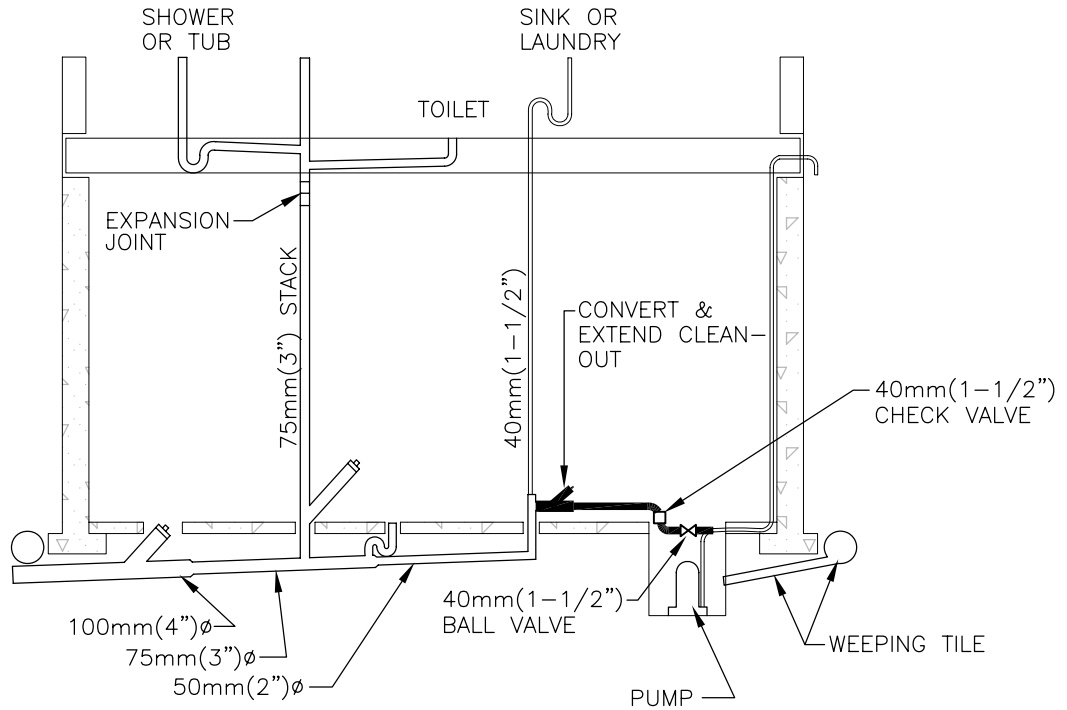

OPTION 1

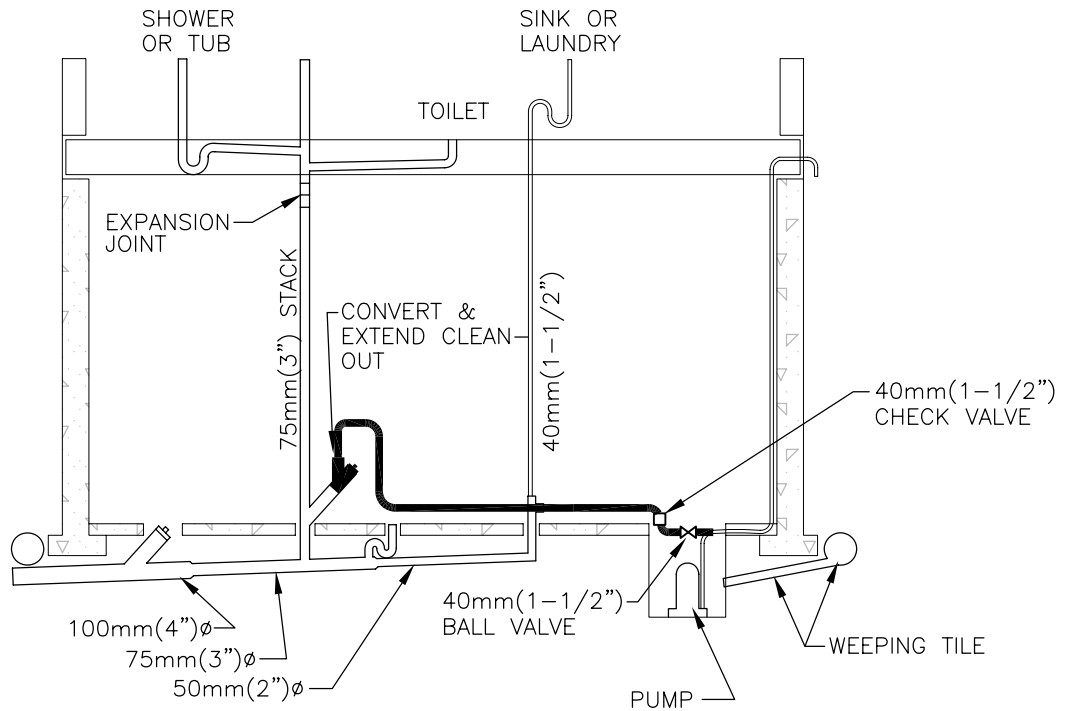

OPTION 2

THE CITY OF
SPRUCE GROVE

PLANNING AND INFRASTRUCTURE

SUMP PUMP BYPASS – SINGLE BALL VALVE

REVISIONS		
DATE	DETAILS	DRAWN



DRAWN: T. CRAWFORD

DATE: MARCH 6, 2006

CHECKED: J. MUSTARD

SCALE: NOT TO SCALE

APPROVED: J. MUSTARD

DRAWING No.: SE-07

XREFS

C:\DETAILS\SHEET2-TK

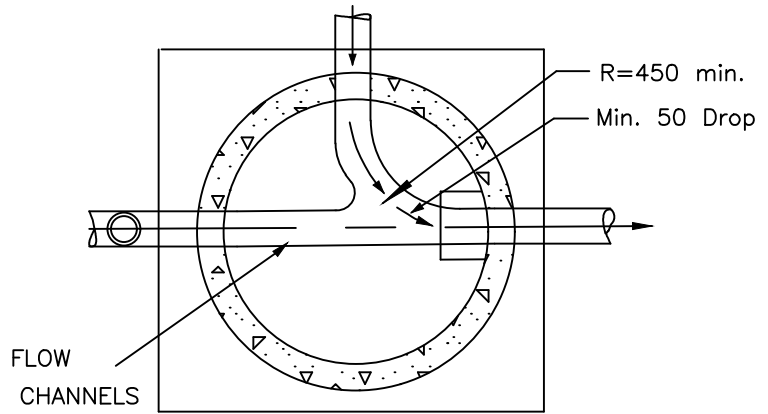
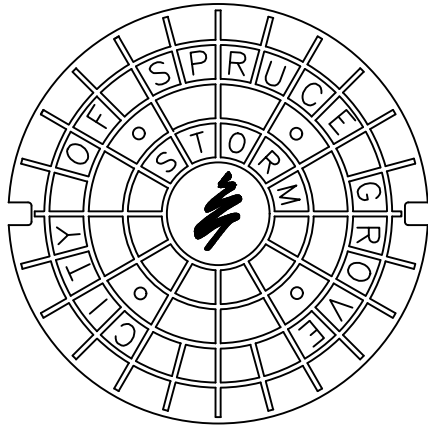

STANDARD FRAME & COVER

USE NORWOOD N.F.80 OR TROJAN T.F.80 ON ALL MANHOLES IN ROADWAYS OR WALKS (SEE DRAWING SM-06)

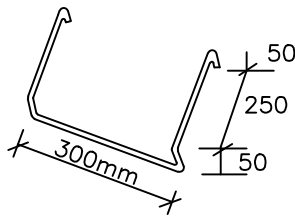

SAFETY TYPE M.H. RUNG

ALUMINUM SPACING TO BE 400mm CENTRE TO CENTRE

USE FLEXIBLE BOOT GASKET FOR WATERTIGHT COUPLING BETWEEN MH AND PVC PIPE
USE BELL & SPIGOT ADAPTOR FOR ULTRA-RIB PIPE

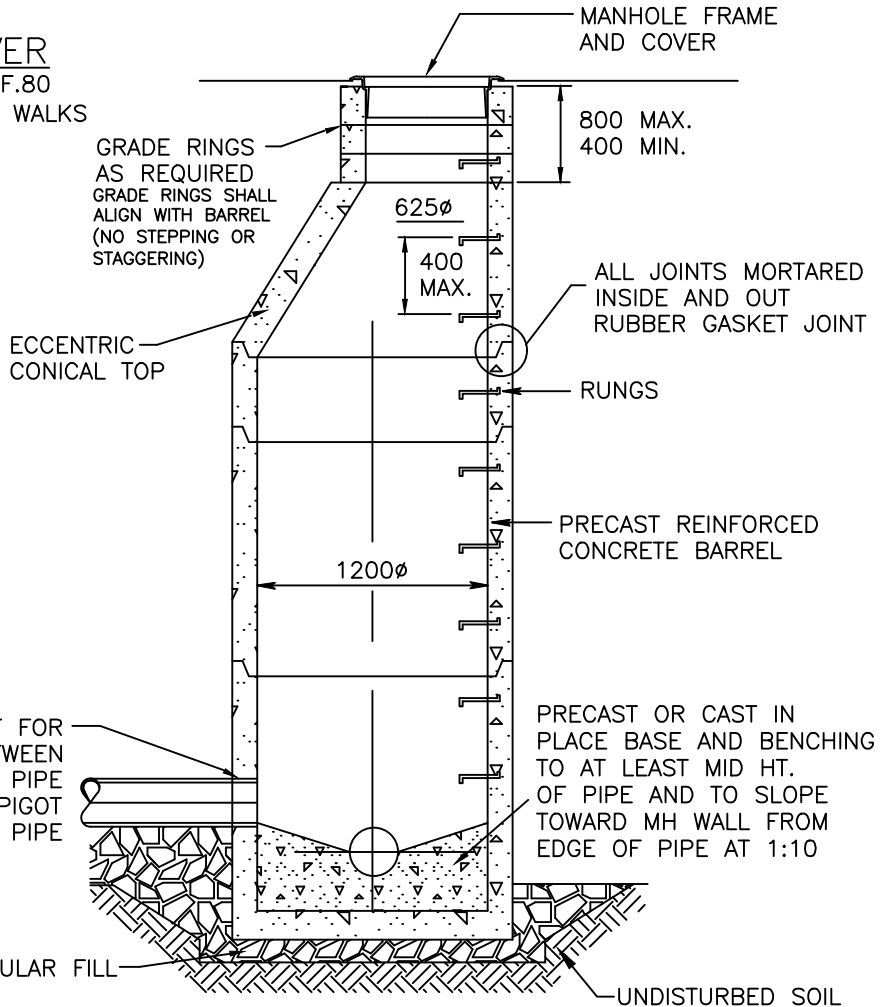

NOTES:

1. MANHOLES OF DEPTH GREATER THAN 7m REQUIRE AN ALUMINUM SAFETY PLATFORM.
2. ALL SEWER MAINS TYING INTO TRUNK MANHOLES MUST BE EXTENDED PAST CONCRETE SLAB SO THAT IT IS BOTH VISIBLE AND ACCESSIBLE FROM THE SURFACE.
3. ANY OVER EXCAVATION TO BE FILLED AS PER GEOTECHNICAL ENGINEER.
4. ALL DIMENSIONS ARE IN MILLIMETERS UNLESS OTHERWISE INDICATED.

THE CITY OF
SPRUCE GROVE

PLANNING AND INFRASTRUCTURE

REVISIONS

DATE	DETAILS	DRAWN
4/19	Standards Update	WPS
9/20	Standards Update	CA
2/22	Standards Update	

STANDARD STORM MANHOLE



DRAWN:	C. ALBARDA	DATE:	FEBRUARY 10, 2022
CHECKED:	B. HANSEN	SCALE:	NOT TO SCALE
APPROVED:	L. KRUSZEWSKI	DRAWING No.:	SM-01

NOTES

1. SAFETY STEPS TO BE SPACED AT 400 MAX. DISTANCE. FIRST STEP TO BE 150 MAX. BELOW FRAME, LAST STEP TO BE 300 MAX. ABOVE BENCHING.
2. ALL JOINTS TO BE SET WITH RUBBER GASKET AND FINISHED WITH NON-SHRINK GROUT INSIDE AND OUTSIDE FOR FULL CIRCUMFERENCE.
3. CHANNELLING AND BENCHING TO BE FINISHED TO TROWEL SMOOTHNESS.
4. COMPACT BACKFILL AROUND MANHOLES TO A MINIMUM OF 97% STANDARD PROCTOR DENSITY.
5. FOR MANHOLES EXCEEDING 7.0m IN DEPTH A SAFETY PLATFORM SHALL BE INSTALLED.
6. THE DEPTHS OF CONCRETE AND REINFORCEMENT FOR THE CONCRETE BASE MUST BE DESIGNED FOR THE SPECIFIC MANHOLE DEPTH AND SOIL CONDITIONS.
7. JOINTS BETWEEN GRADE RINGS, GRADE RINGS AND CONES, AND BETWEEN RINGS AND FRAMES MUST BE WATERTIGHT.
8. ALL DIMENSIONS ARE IN MILLIMETERS UNLESS OTHERWISE INDICATED.
9. ANY OVER EXCAVATION TO BE FILLED AS PER GEOTECHNICAL ENGINEER.

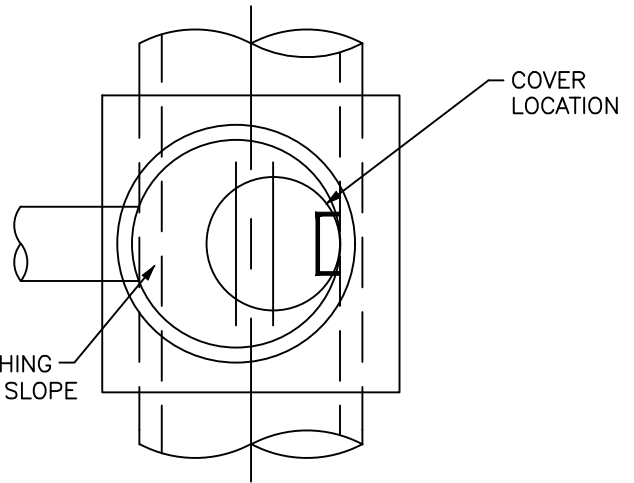

FRAME—COVER TO BE NF80/TF80
MANHOLE COVER OR ROUND
CATCH BASIN TOP AS INDICATED

ADJUSTMENT RINGS
400 MIN. 800 MAX.

MANHOLE RUNGS
CAST IN BARRELS
— 400 SPACING

CONNECTED FLUSH
WITH WALL

USE FLEXIBLE BOOT GASKET
FOR WATERTIGHT COUPLING
BETWEEN MH AND PVC PIPE
USE BELL & SPIGOT ADAPTER
FOR ULTRA-RIB PIPE

COMPACTED GRANULAR
BACKFILL TO LIMIT OF
EXCAVATION

25.0MPa CONCRETE
TWO LAYERS OF 10M REBAR
EACH WAY, 150mm APART,
75mm SEPARATION FROM
CONCRETE SURFACE

UNDISTURBED SOIL

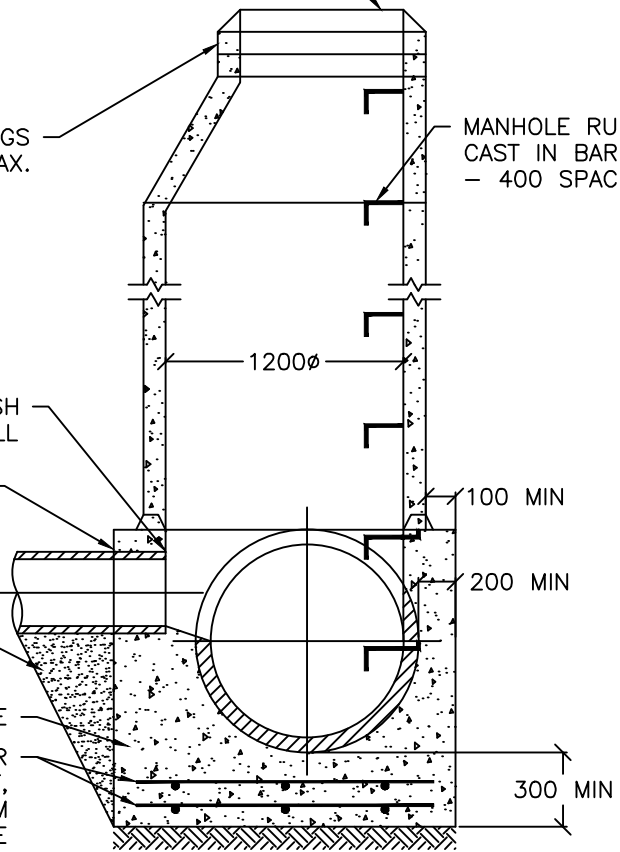

(625mm TO 1050mm PIPE)

THE CITY OF
SPRUCE GROVE

PLANNING AND INFRASTRUCTURE

REVISIONS

DATE	DETAILS	DRAWN
4/19	Standards Update	WPS
9/20	Standards Update	CA
2/22	Standards Update	

PERCHED MANHOLE



DRAWN: C. ALBARDA	DATE: FEBRUARY 10, 2022
CHECKED: B. HANSEN	SCALE: NOT TO SCALE
APPROVED: L. KRUSZEWSKI	DRAWING No.: SM-02

NOTES:

1. THIS TYPE OF MANHOLE IS TO BE BUILT ONLY ON MAINS OF 1200mm DIAMETER OR LARGER AND WHERE THERE IS NO CHANGE IN DIRECTION.
2. SAFETY STEPS TO BE SPACED AT 400 MAX. DISTANCE. FIRST STEP TO BE 150 MAX. BELOW FRAME, LAST STEP TO BE 300 MAX. ABOVE BENCHING.
3. FOR MANHOLES EXCEEDING 7.0m IN DEPTH A SAFETY PLATFORM SHALL BE INSTALLED.
4. WHERE REQUIRED, CATCH BASIN LEADS SHALL ENTER MANHOLE IN PIPEZONE.

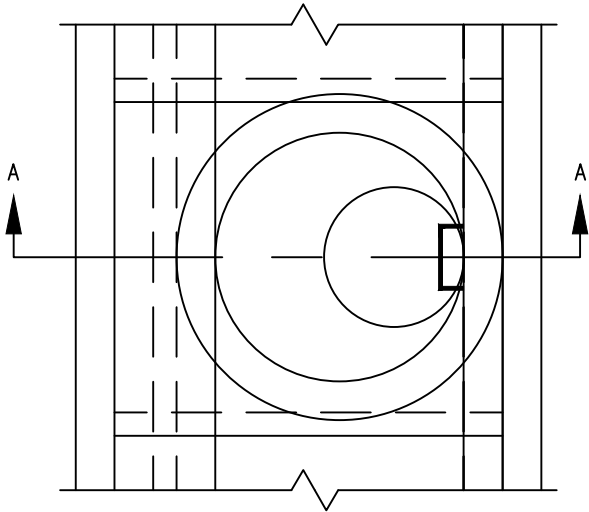

SEE TYPICAL MANHOLE DRAWINGS FOR DETAILS OF BARREL

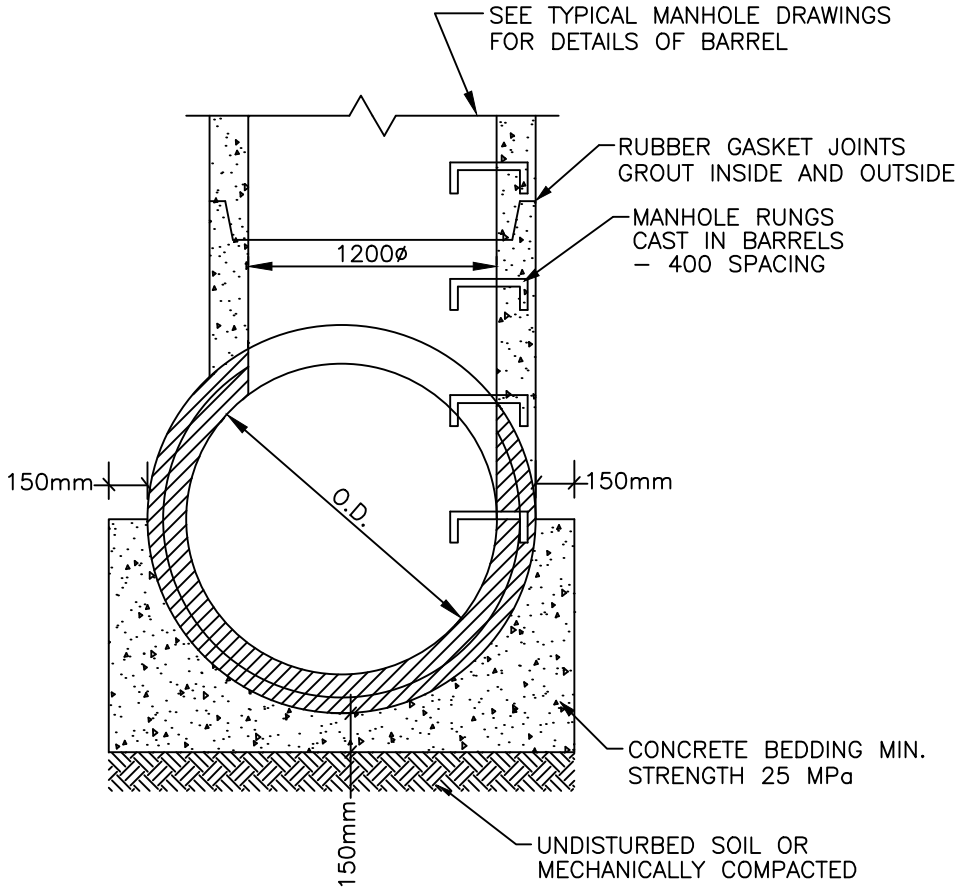

SECTION A-A

(1200mm AND LARGER PIPES)

THE CITY OF
SPRUCE GROVE

PLANNING AND INFRASTRUCTURE

REVISIONS

DATE	DETAILS	DRAWN

T-RISER MANHOLE



DRAWN: T. CRAWFORD	DATE: MARCH 6, 2006
CHECKED: J. MUSTARD	SCALE: NOT TO SCALE
APPROVED: J. MUSTARD	DRAWING No.: SM-03

XREFS

C:\DETAILS\SHEET2-TK

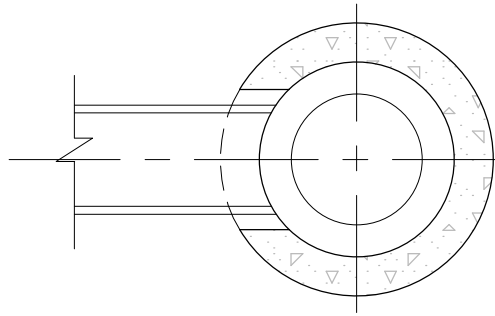

SECTION A-A

100 OR 150 NECK RING TO SUIT SUBGRADE.

FOR HIGH ROLL FACE CURB USE 150 OR 100 TAPERED NECK RING

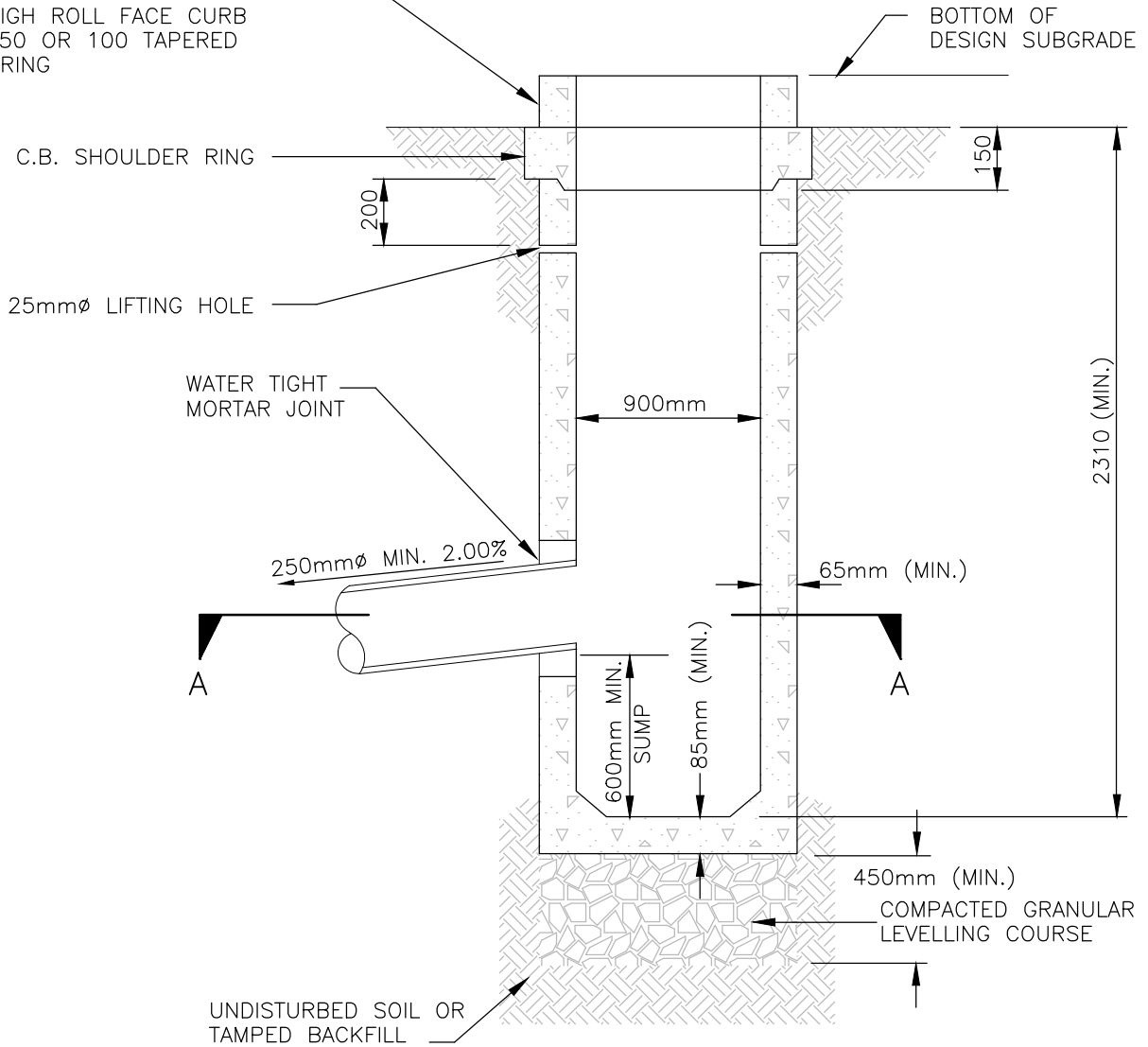

XREFS

C:\DETAILS\SHEET2-TK

THE CITY OF
SPRUCE GROVE

PLANNING AND INFRASTRUCTURE

REVISIONS

DATE	DETAILS	DRAWN
02/04/13	Change to depth	RP
02/04/13	Washed rock note	RP

PRECAST CATCH BASIN



DRAWN: T. CRAWFORD	DATE: MARCH 6, 2006
CHECKED: J. MUSTARD	SCALE: NOT TO SCALE
APPROVED: J. MUSTARD	DRAWING No.: SM-04

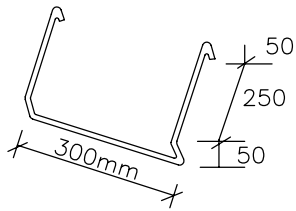

SAFETY TYPE M.H. RUNG

GALVANIZED IRON SPACING
TO BE 400mm CENTRE
TO CENTRE

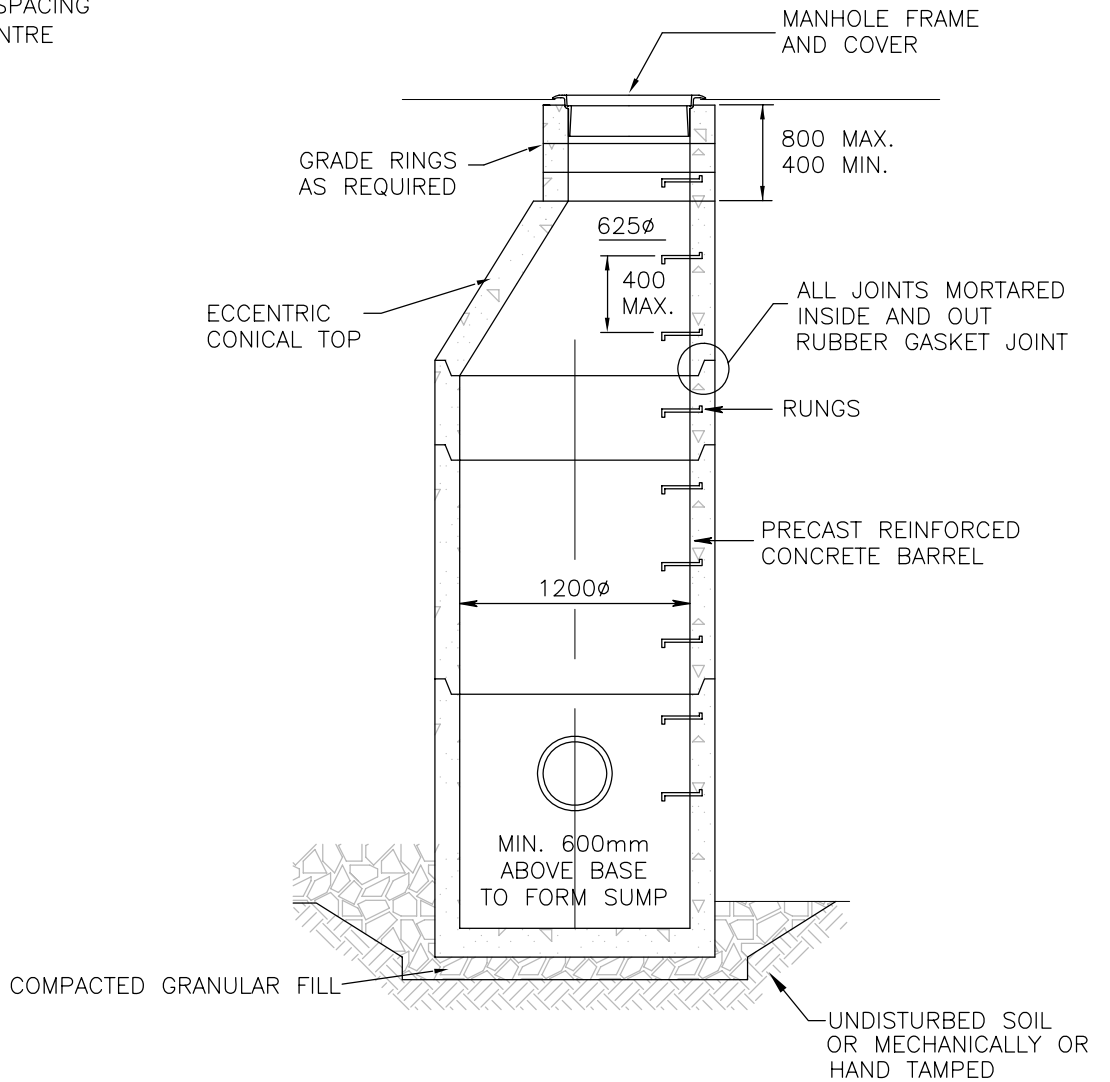

XREFS

C:\DETAILS\SHEET2-TK

THE CITY OF
SPRUCE GROVE

PLANNING AND INFRASTRUCTURE

STANDARD CB MANHOLE

REVISIONS		
DATE	DETAILS	DRAWN



DRAWN: T. CRAWFORD	DATE: MARCH 6, 2006
CHECKED: J. MUSTARD	SCALE: NOT TO SCALE
APPROVED: J. MUSTARD	DRAWING No.: SM-05

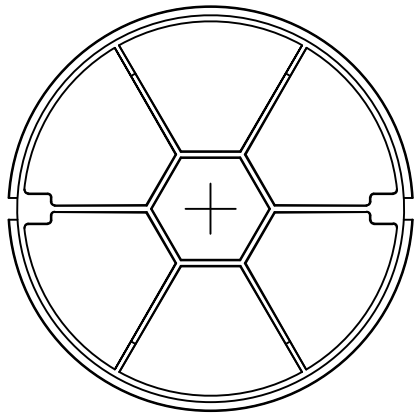

BOTTOM VIEW

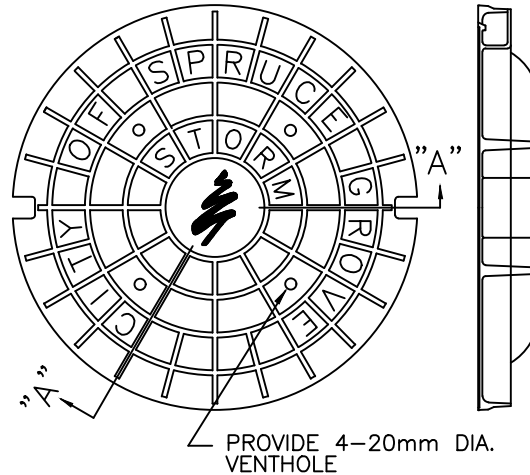

TOP VIEW

SECTION "A-A"

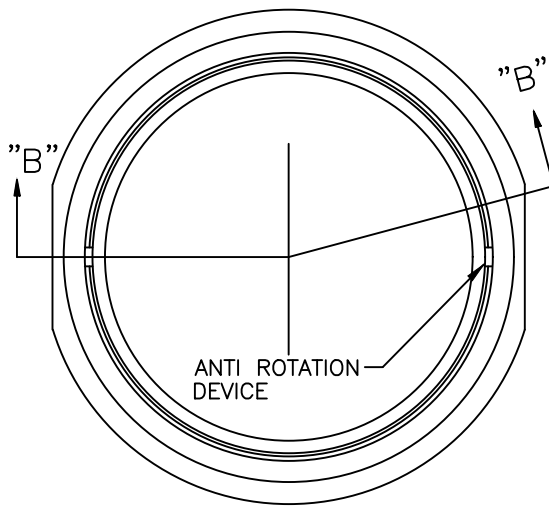

PLAN

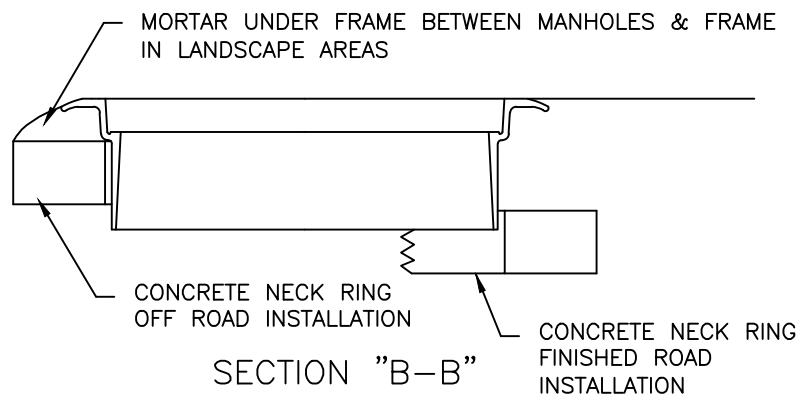

SECTION "B-B"

NOTES

1. NORWOOD FOUNDRY TYPE NF80 OR TROJAN FOUNDRY TYPE TF80 GROUT TO BE INSTALLED BETWEEN FLANGE AND MANHOLE BARREL ON RAISED MANHOLES.

XREFS

C:\DETAILS\SHEET2-TK

THE CITY OF
SPRUCE GROVE

PLANNING AND INFRASTRUCTURE

REVISIONS		
DATE	DETAILS	DRAWN
04/12	Drawing Number	RP
04/19	Standards Update	WPS
09/20	Standards Update	CA

NF/TF-80 FRAME AND COVER - STORM



DRAWN: C. ALBARDA	DATE: September 3, 2020
CHECKED: B. HANSON	SCALE: NOT TO SCALE
APPROVED: L. KRUSZEWSKI	DRAWING No.: SM-06

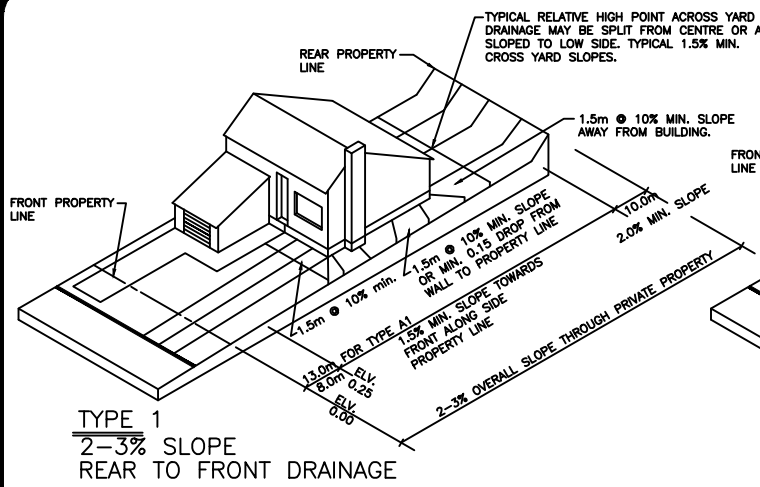

TYPE 1
2-3% SLOPE
REAR TO FRONT DRAINAGE

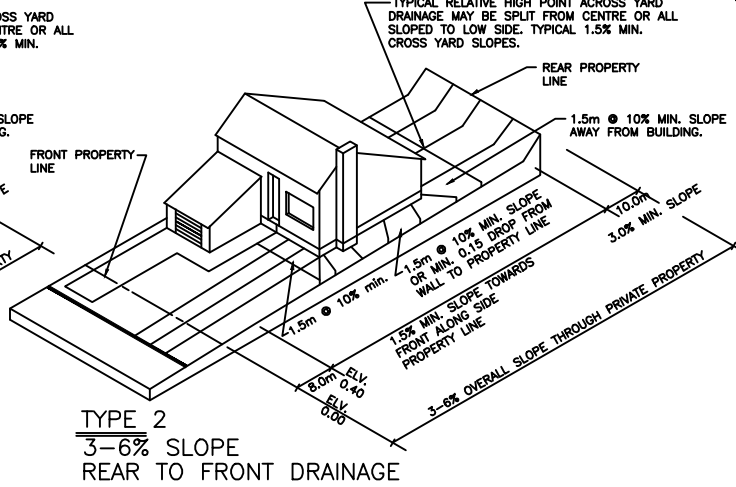

TYPE 2
3-6% SLOPE
REAR TO FRONT DRAINAGE

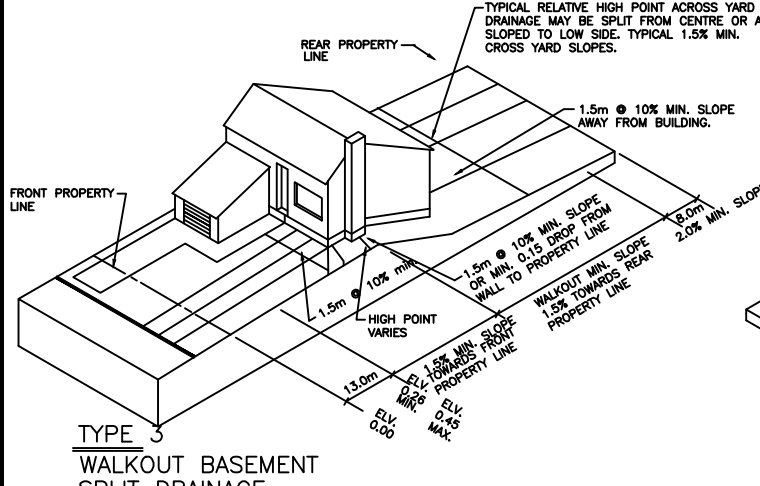

TYPE 3
WALKOUT BASEMENT
SPLIT DRAINAGE

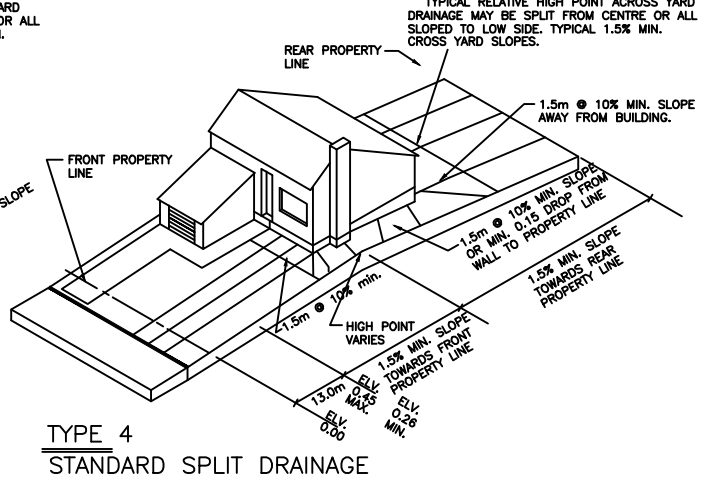

TYPE 4
STANDARD SPLIT DRAINAGE

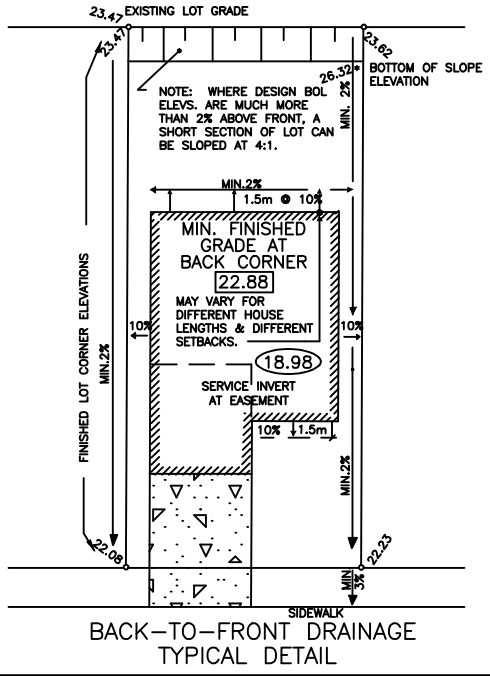

BACK-TO-FRONT DRAINAGE
TYPICAL DETAIL

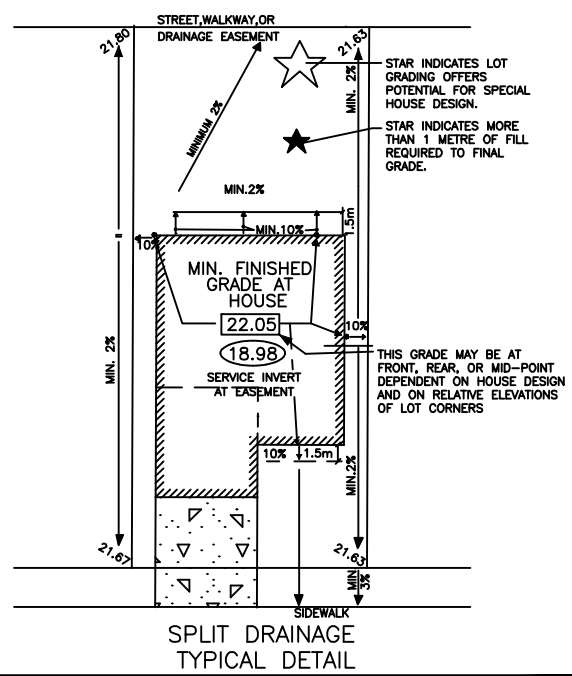

SPLIT DRAINAGE
TYPICAL DETAIL

THE CITY OF SPRUCE GROVE PLANNING AND INFRASTRUCTURE

P:\Municipal Development Standards\2022 FULL MDS

REVISIONS		
DATE	DETAILS	DRAWN
4/12	Drawing Number	RP
4/12	Changes to notes	RP
2/22	Standards Update	

LOT GRADING		
	DRAWN: T. CRAWFORD	DATE: FEBRUARY 18, 2022
	CHECKED: J. MUSTARD	SCALE: NOT TO SCALE
	APPROVED: J. MUSTARD	DRAWING No.: SM-07A

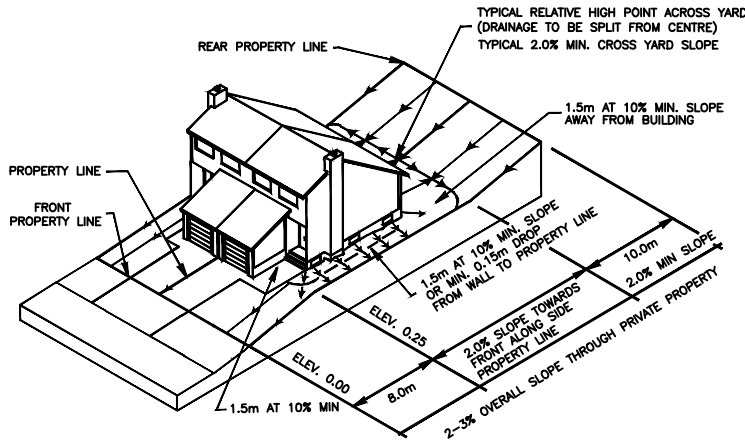

TYPE 5
 DUPLEX 2-3% SLOPE
 REAR TO FRONT DRAINAGE

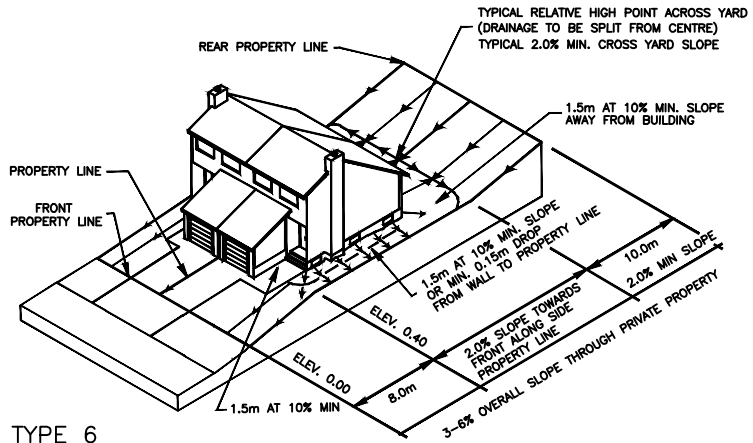

TYPE 6
 DUPLEX 3-6% SLOPE
 REAR TO FRONT DRAINAGE

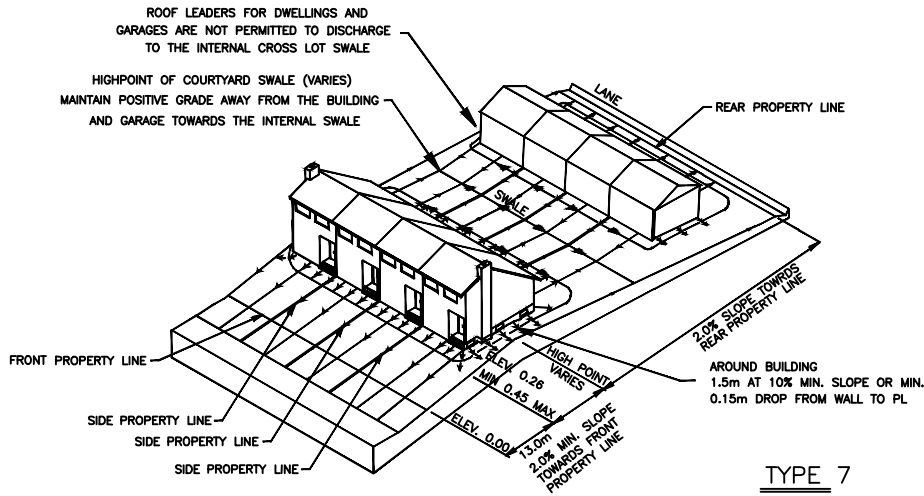

TYPE 7
 FOURPLEX
 SPLIT DRAINAGE

THE CITY OF
 SPRUCE GROVE

PLANNING AND INFRASTRUCTURE

REVISIONS

DATE	DETAILS	DRAWN
2/22	Standards Update	

LOT GRADING FOR DUPLEX



DRAWN:	DATE: FEBRUARY 18, 2022
CHECKED: M. HUSSEY	SCALE: NOT TO SCALE
APPROVED: M. HUSSEY	DRAWING No.: SM-07B

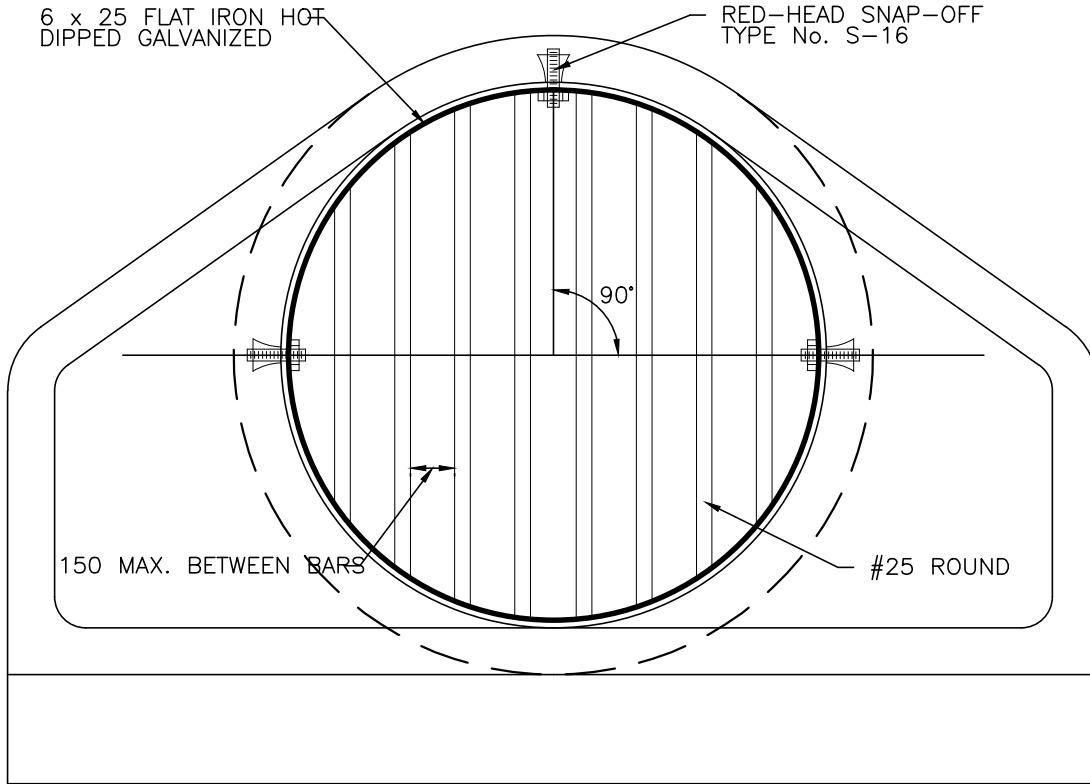

FRONT VIEW

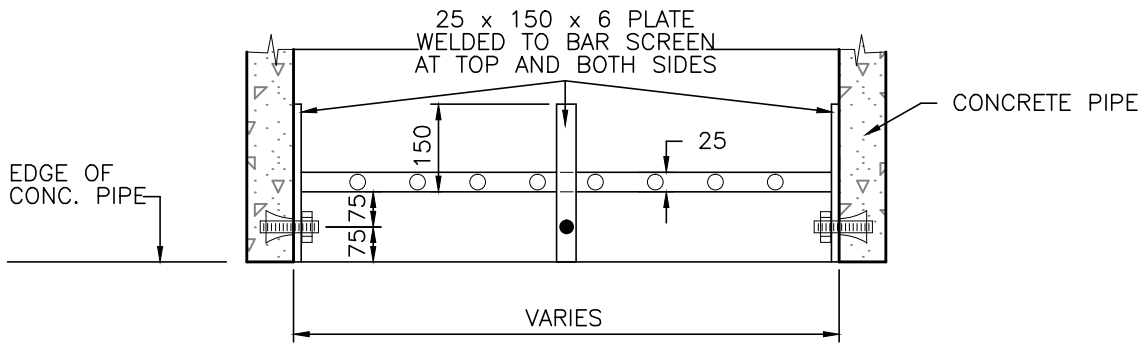

TOP VIEW

NOTE: ALL DIMENSIONS ARE IN MILLIMETERS UNLESS SHOWN OTHERWISE.

THE CITY OF
SPRUCE GROVE

PLANNING AND INFRASTRUCTURE

REVISIONS

DATE	DETAILS	DRAWN
02/14	Drawing Number	RP

VERTICAL BAR SCREEN



DRAWN: T. CRAWFORD	DATE: MARCH 6, 2006
CHECKED: J. MUSTARD	SCALE: NOT TO SCALE
APPROVED: J. MUSTARD	DRAWING No.: SM-08

XREFS

C:\DETAILS\SHEET2-TK

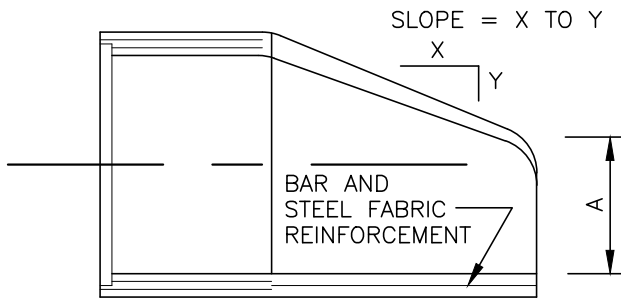

LONGITUDINAL SECTION

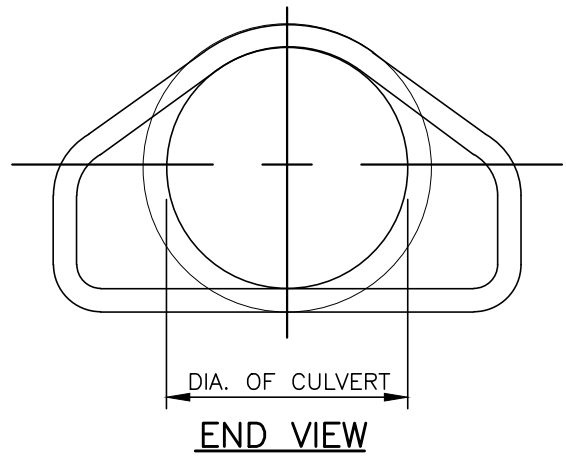

END VIEW

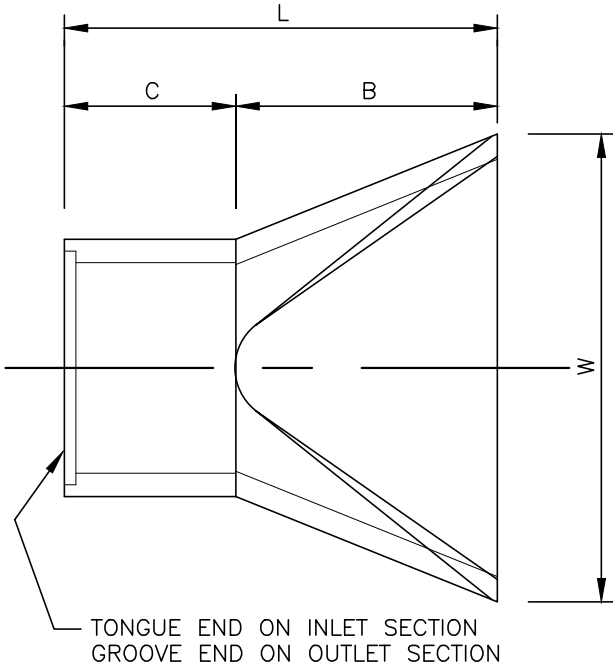

PLAN VIEW

DIA. (mm)	WT SEC (kg)	SLOPE	A (mm)	B (mm)	C (mm)	D (mm)	E (mm)
450	450	3T01	225	680	1150	1825	900
600	690	3T01	240	940	750	1850	1200
750	990	3T01	300	1090	750	1830	1500
900	1860	3T01	375	1350	475	2440	1800
1200	2900	3T01	600	1800	650	2450	2100

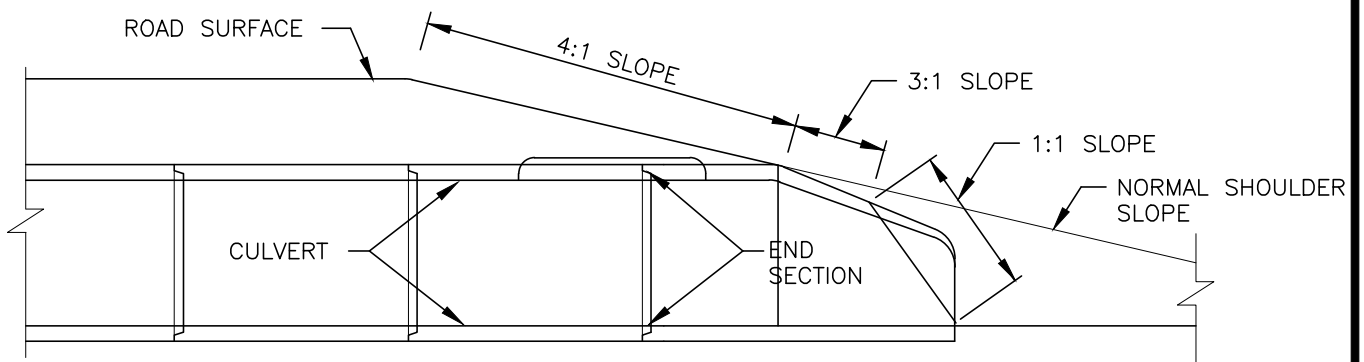

TYPICAL SLOPE DETAIL

THE CITY OF
SPRUCE GROVE

PLANNING AND INFRASTRUCTURE

REVISIONS

DATE	DETAILS	DRAWN
4/12	Drawing Number	RP

CONCRETE CULVERT



DRAWN: T. CRAWFORD	DATE: MARCH 6, 2006
CHECKED: J. MUSTARD	SCALE: NOT TO SCALE
APPROVED: J. MUSTARD	DRAWING No.: SM-09

XREFS

C:\DETAILS\SHEET2-TK

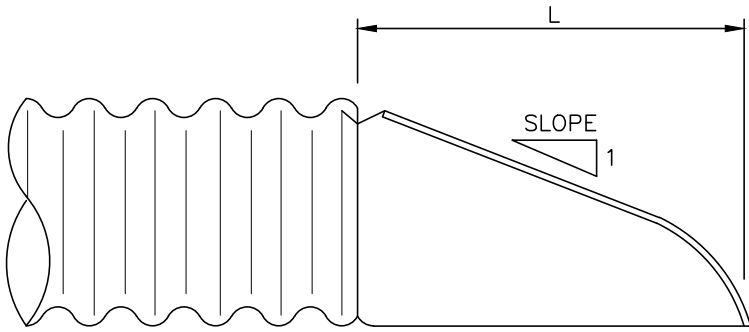

TYPICAL CROSS SECTION

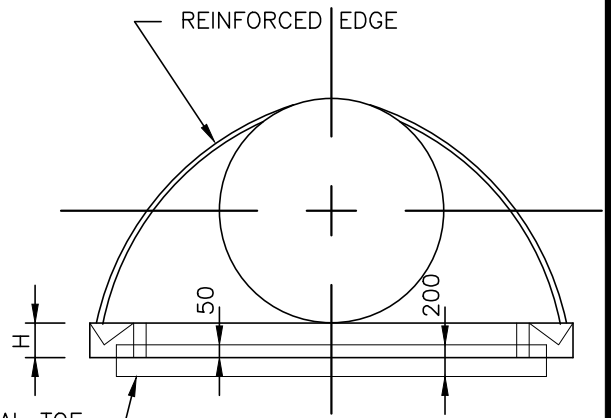

ELEVATION

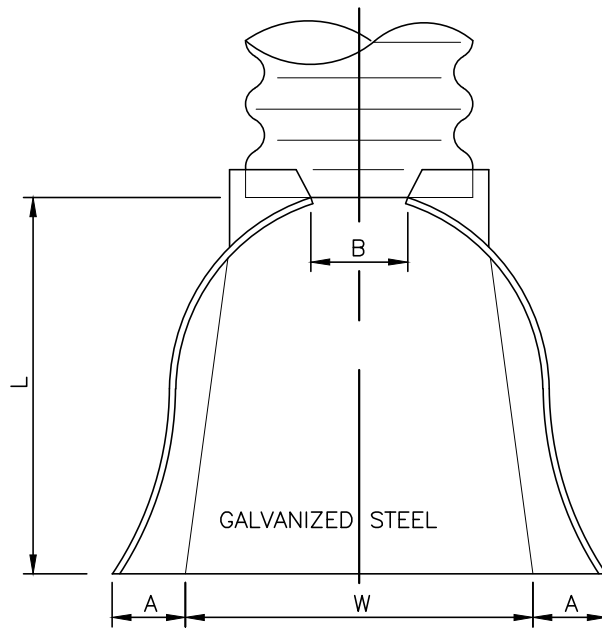

PLAN

PIPE DIAMETER "D" mm	GALVANIZED METAL THICKNESS mm	DIMENSIONS, mm					APPROXIMATE SLOPE	BODY
		A mm ±	B MAX mm	H mm ±	L mm ±	W mm ±		
300	1.6	150	140	150	535	610	2.5	1 Pc
600	1.6	250	300	150	1040	1220	2.5	1 Pc
1200	1.6	460	625	305	1980	2285	2.25	2 Pc

THE CITY OF
SPRUCE GROVE

PLANNING AND INFRASTRUCTURE

REVISIONS

DATE	DETAILS	DRAWN
02/14	Drawing Number	RP

STEEL CULVERT



DRAWN: T. CRAWFORD	DATE: MARCH 6, 2006
CHECKED: J. MUSTARD	SCALE: NOT TO SCALE
APPROVED: J. MUSTARD	DRAWING No.: SM-10

XREFS

C:\DETAILS\SHEET2-TK

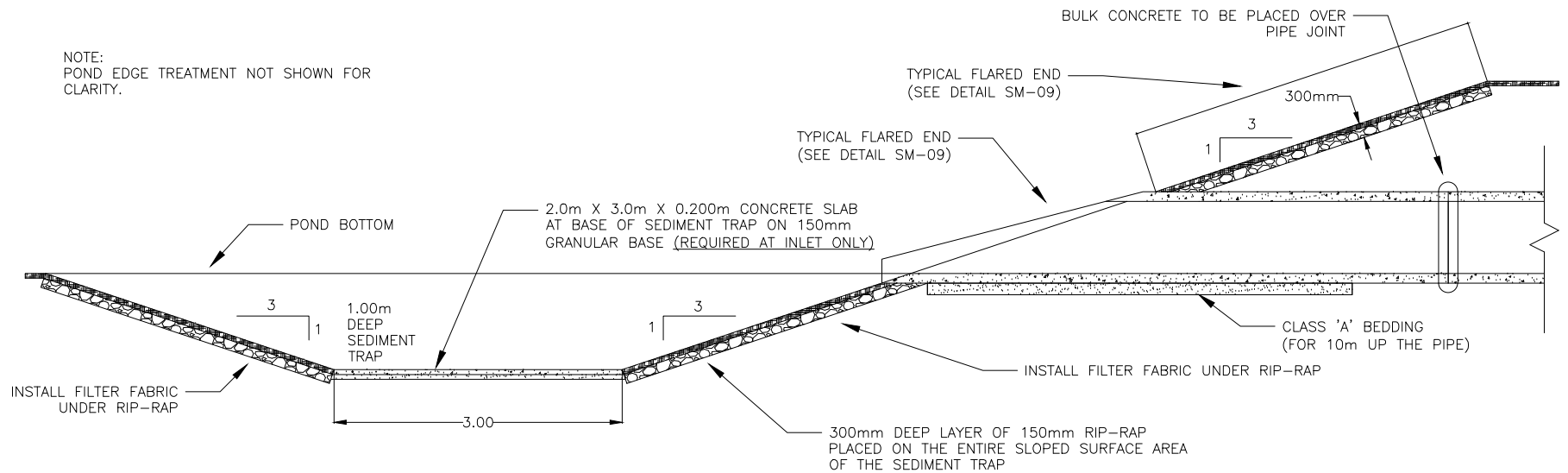

THE CITY OF
SPRUCE GROVE

PLANNING AND INFRASTRUCTURE

REVISIONS		
DATE	DETAILS	DRAWN

INLET/OUTLET DETAIL



DRAWN: S.WILLIAMS	DATE: MARCH 4, 2014
CHECKED: J. MUSTARD	SCALE: NOT TO SCALE
APPROVED: J. MUSTARD	DRAWING No.: SM-11

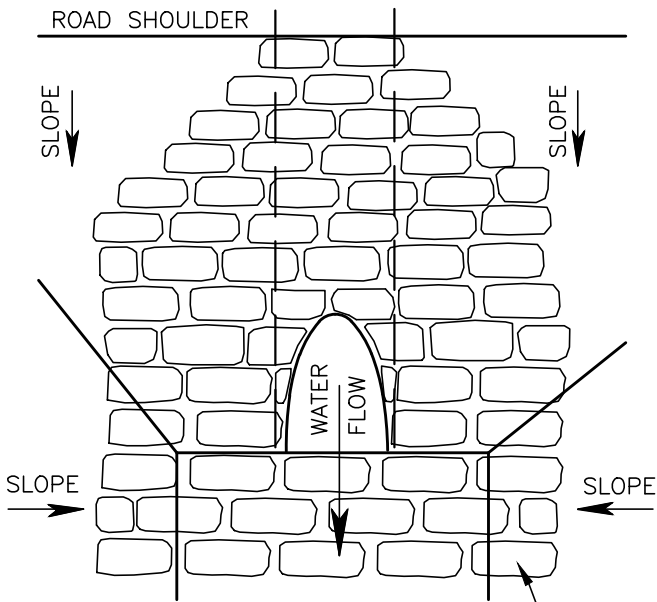

PLAN VIEW

RIP-RAP SLOPE AND
END PROTECTION

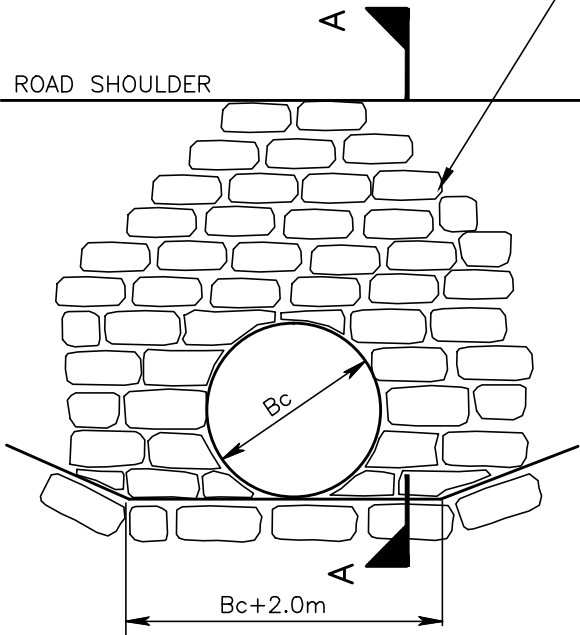

FRONT VIEW

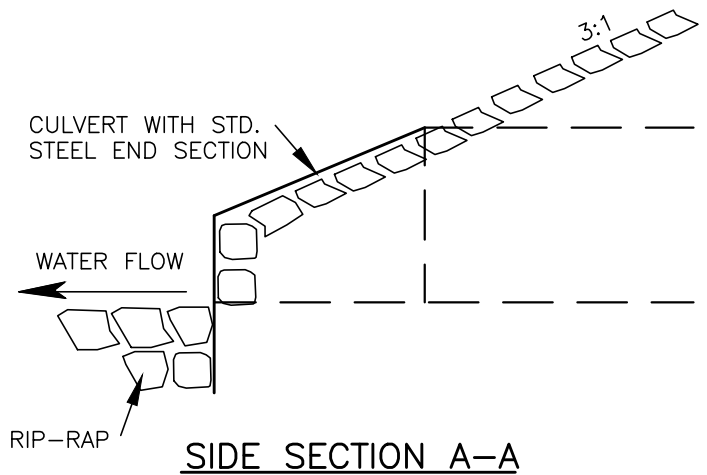

SIDE SECTION A-A

XREFS

C:\DETAILS\SHEET2-TK

THE CITY OF
SPRUCE GROVE

PLANNING AND INFRASTRUCTURE

RIP-RAP

REVISIONS		
DATE	DETAILS	DRAWN
4/12	Drawing Number	RP



DRAWN: T. CRAWFORD
CHECKED: J. MUSTARD
APPROVED: J. MUSTARD

DATE: MARCH 6, 2006
SCALE: NOT TO SCALE
DRAWING No.: SM-12

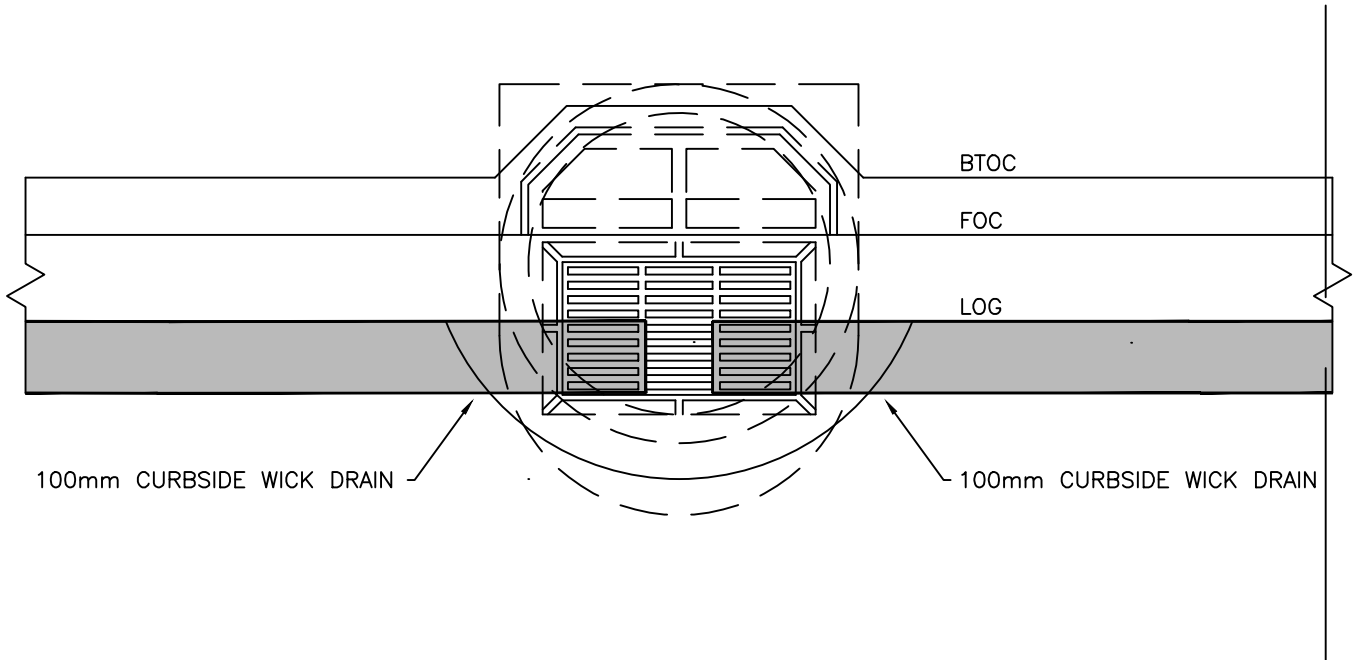

NOTES:

1. ALL DIMENSIONS ARE IN MILLIMETERS UNLESS OTHERWISE NOTED.
2. WICK DRAINS TO BE CUT 300mm INSIDE CB AND MUST BE VISIBLE.

XREFS

THE CITY OF
SPRUCE GROVE

PLANNING AND INFRASTRUCTURE

C:\DETAILS\SHEET2-TK

REVISIONS			WICK DRAIN CONNECTION TO CB		
DATE	DETAILS	DRAWN			
04/12	Removed Tranv Wick Drain	RP		DRAWN: T. CRAWFORD	DATE: MARCH 6, 2006
04/12	Drawing Number	RP		CHECKED: J. MUSTARD	SCALE: NOT TO SCALE
02/14	Additional Note	RP			
04/19	Standards Update	WPS		APPROVED: J. MUSTARD	DRAWING No.: SM-13

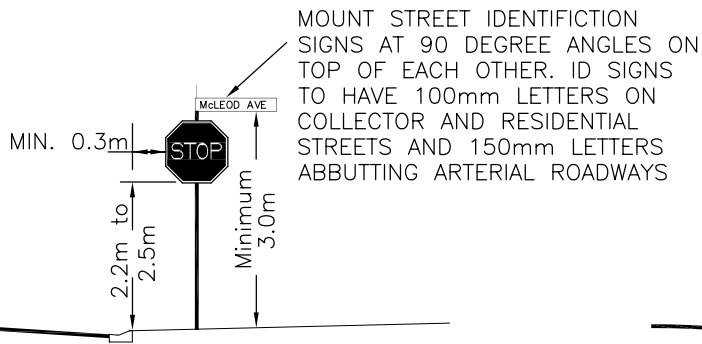

MOUNT STREET IDENTIFICATION SIGNS AT 90 DEGREE ANGLES ON TOP OF EACH OTHER. ID SIGNS TO HAVE 100mm LETTERS ON COLLECTOR AND RESIDENTIAL STREETS AND 150mm LETTERS ABUTTING ARTERIAL ROADWAYS

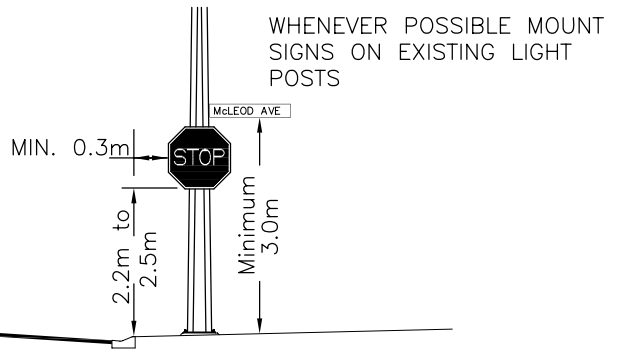

WHENEVER POSSIBLE MOUNT SIGNS ON EXISTING LIGHT POSTS

LOCAL RESIDENTIAL STREET

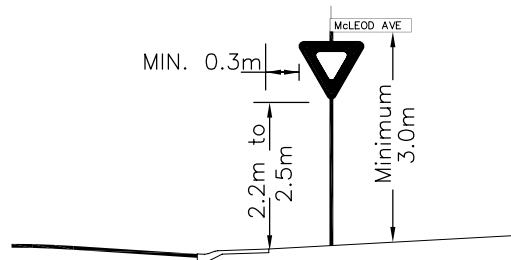

LOCAL RESIDENTIAL STREET

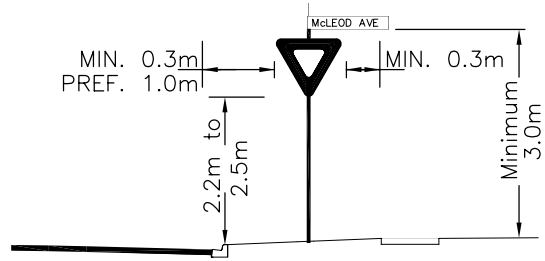

COLLECTOR STREET

** WHERE PRACTICAL MOUNT STREET NAME SIGNS:

- 1) ON A STREET LIGHT STANDARD AT THE INTERSECTION.
- 2) ON THE TOP OF A YIELD OR STOP SIGN POST AT THE INTERSECTION.
- 3) ON A SEPARATE POST ONLY IF THE ABOVE 2 LOCATIONS ARE NOT SUITABLE.

THE CITY OF
SPRUCE GROVE

PLANNING AND INFRASTRUCTURE

REVISIONS

DATE	DETAILS	DRAWN

TRAFFIC SIGNAGE



DRAWN: T. CRAWFORD	DATE: MARCH 6, 2006
CHECKED: J. MUSTARD	SCALE: NOT TO SCALE
APPROVED: J. MUSTARD	DRAWING No.: SN-01

XREFS

C:\DETAILS\SHEET2-TK

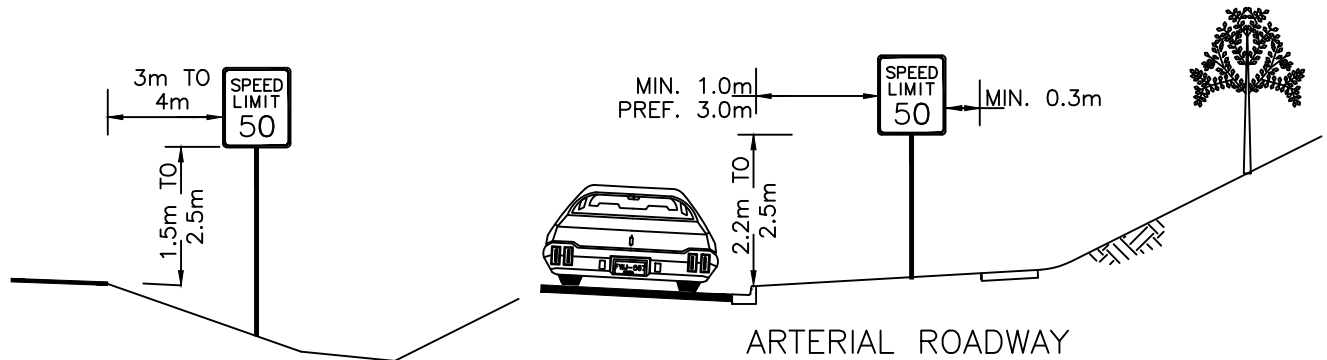

RURAL/INDUSTRIAL

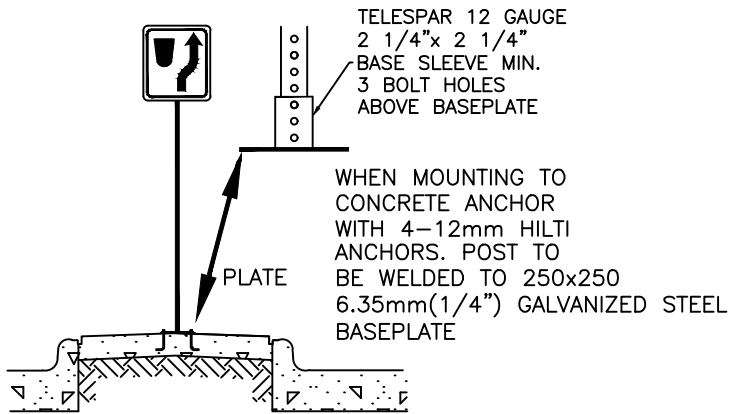

MEDIAN/CONCRETE DETAIL

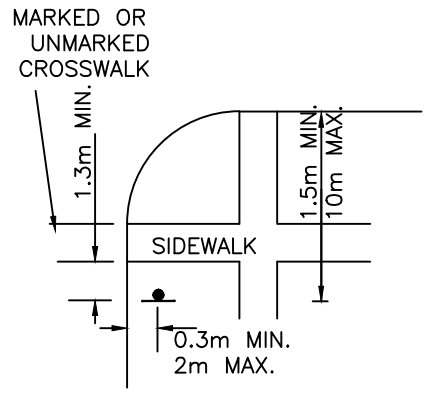

INTERSECTION DETAIL

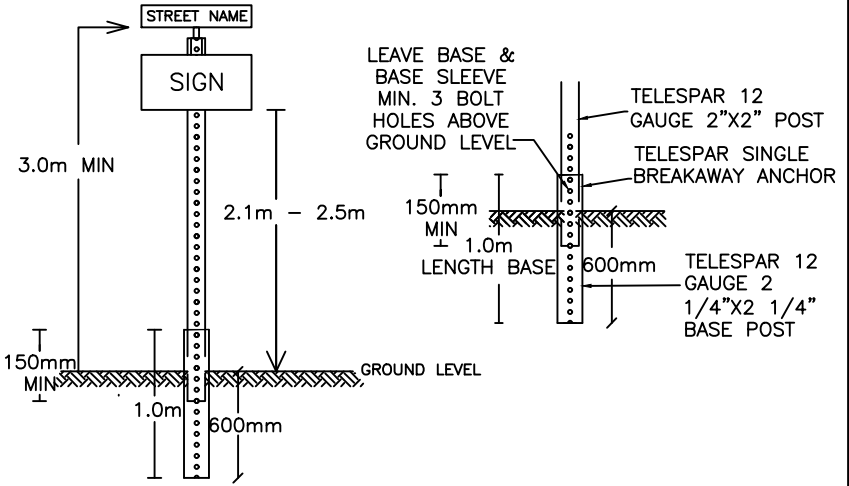

MATERIALS DETAIL

1. ALL DIMENSIONS ARE IN MILLIMETERS UNLESS OTHERWISE INDICATED
2. WHERE SIGN ROTATION DUE TO WIND IS EXPECTED, TELESPAR OMNI-DIRECTIONAL ANCHOR OR APPROVED EQUAL SHALL BE USED.

THE CITY OF
SPRUCE GROVE

PLANNING AND INFRASTRUCTURE

REVISIONS

DATE	DETAILS	DRAWN
02/14	MATERIAL SIZE	RP
04/15	ADDT'L MATERIAL	RP
09/20	STANDARDS UPDATE	WPS

TRAFFIC SIGNAGE



DRAWN: T. CRAWFORD	DATE: MARCH 6, 2006
CHECKED: J. MUSTARD	SCALE: NOT TO SCALE
APPROVED: J. MUSTARD	DRAWING No.: SN-02

XREFS

C:\DETAILS\SHEET2-TK

PARALLEL LINES

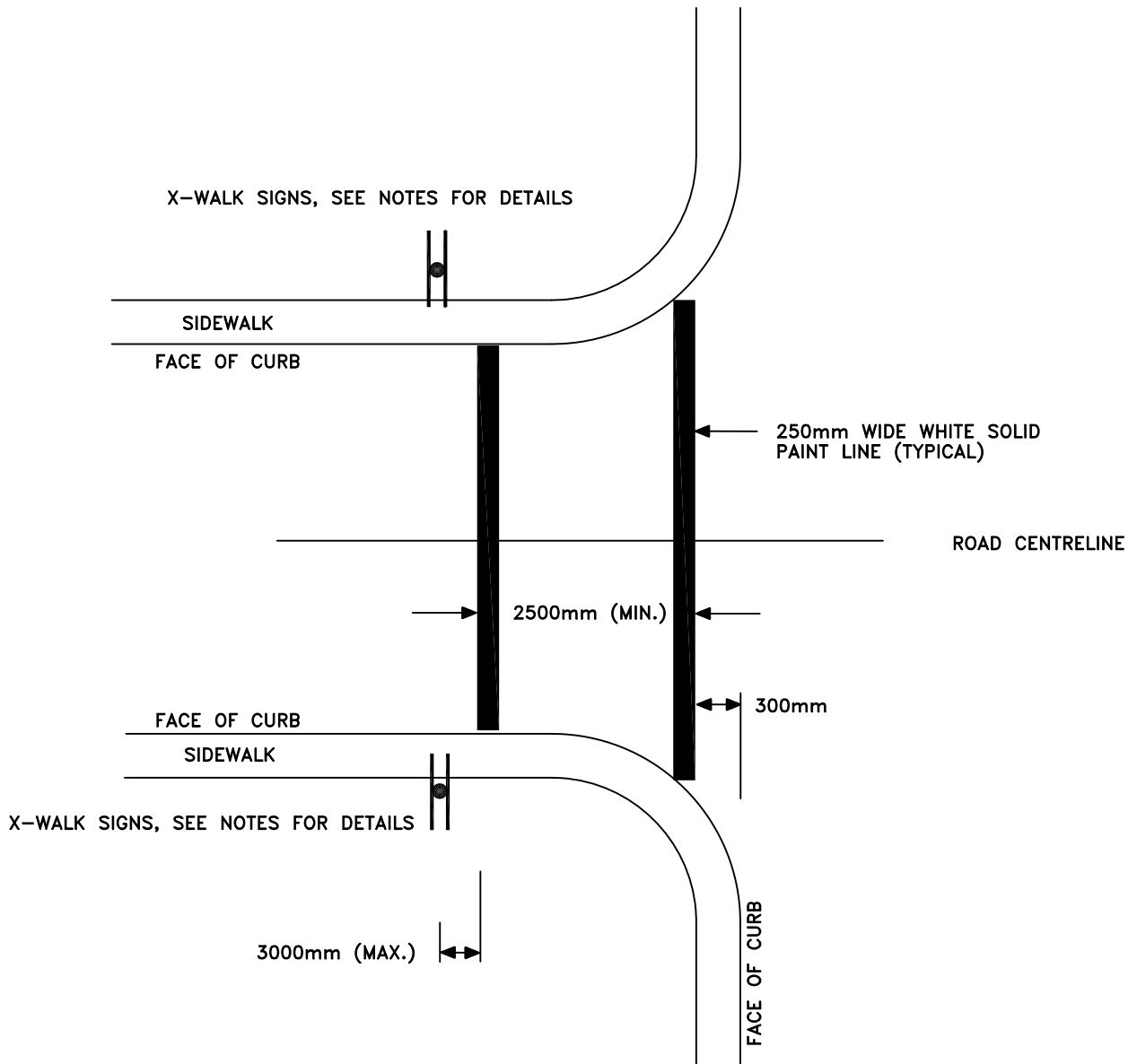

NOTES:

1. WHEN WARRANTED, USE AT PASSIVE X-WALKS ON COLLECTOR AND LOCAL ROADS UNLESS SPECIAL CIRCUMSTANCES EXIST (SEE SN-04) IN WHICH CASE, ZEBRA LINES ARE TO BE USED
2. USE FLUORESCENT LIME YELLOW RA-4R/L SIGNS
3. MOUNT SIGNS BACK-TO-BACK ON BOTH SIDES OF AN UNDIVIDED ROAD AND WHEN THE ROAD IS DIVIDED, MOUNT SINGLE SIDED ON THE RIGHT SIDE OF THE ROAD AND BACK-TO BACK ON THE MEDIAN
4. MOUNT SIGNS IN ADVANCE OF THE X-WALK WHERE PRACTICAL

THE CITY OF
SPRUCE GROVE

PLANNING AND INFRASTRUCTURE

REVISIONS

DATE	DETAILS	DRAWN
01/21	LINE WIDTH & DIST. BTW	HW
01/21	ADD SIGN	HW
01/21	UPDATE NOTES	HW
01/21	TITLE CHANGE	HW

PASSIVE CROSSWALK – PARALLEL LINES



DRAWN: T. CRAWFORD	DATE: MARCH 6, 2006
CHECKED: J. MUSTARD	SCALE: NOT TO SCALE
APPROVED: J. MUSTARD	DRAWING No.: SN-03

XREFS

C:\DETAILS\SHEET2-TK

ZEBRA LINES

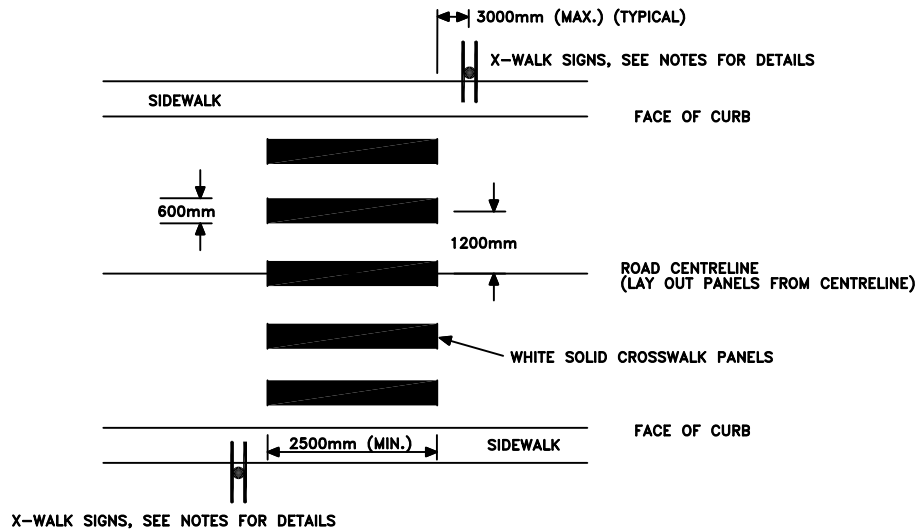

NOTES:

1. USE FLUORESCENT LIME YELLOW RA-3R/L SIGNS IN NON-SCHOOL AREA/ZONE
2. USE FLUORESCENT LIME YELLOW RA-4R/L SIGNS IN SCHOOL AREA/ZONE
3. USE AT PASSIVE X-WALKS ON ALL ARTERIAL ROADS AND ON COLLECTOR AND LOCAL ROADS WHEN THE FOLLOWING CIRCUMSTANCES EXIST: SCHOOL/PLAYGROUND AREA OR ZONE, WITHIN 100m OF SCHOOL GROUNDS, CONNECTS A PATHWAY, MID-BLOCK, OR FREQUENTLY USED BY ELDERLY & MOBILITY IMPAIRED
4. MOUNT SIGNS BACK-TO-BACK ON BOTH SIDES OF AN UNDIVIDED ROAD AND WHEN THE ROAD IS DIVIDED, MOUNT SINGLE SIDED ON THE RIGHT SIDE OF THE ROAD AND BACK-TO BACK ON THE MEDIAN

CHANNELIZED RIGHT TURN

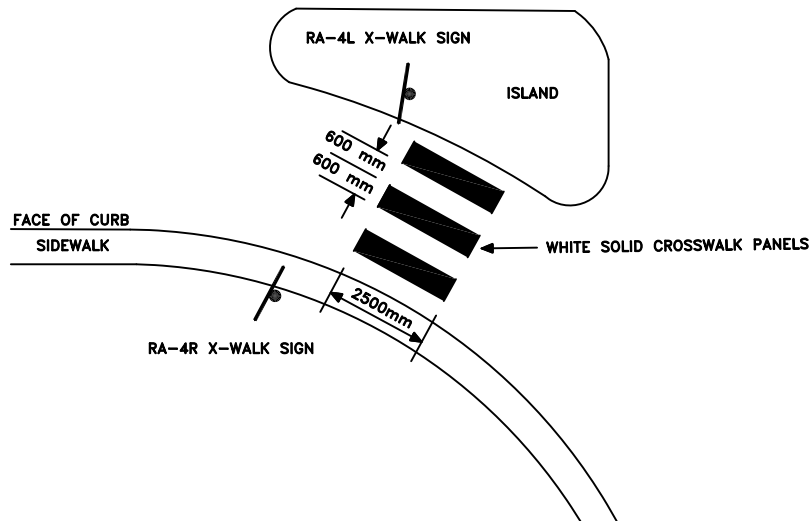

THE CITY OF
SPRUCE GROVE

PLANNING AND INFRASTRUCTURE

REVISIONS

DATE	DETAILS	DRAWN
01/21	LINE LENGTH & DIST BTW	HW
01/21	ADD SIGNS	HW
01/21	UPDATE NOTES	HW
01/21	TITLE CHANGE	HW

PASSIVE CROSSWALK – ZEBRA LINES



DRAWN: T. CRAWFORD

DATE: MARCH 6, 2006

CHECKED: J. MUSTARD

SCALE: NOT TO SCALE

APPROVED: J. MUSTARD

DRAWING No.: SN-04

XREFS

C:\DETAILS\SHEET2-TK

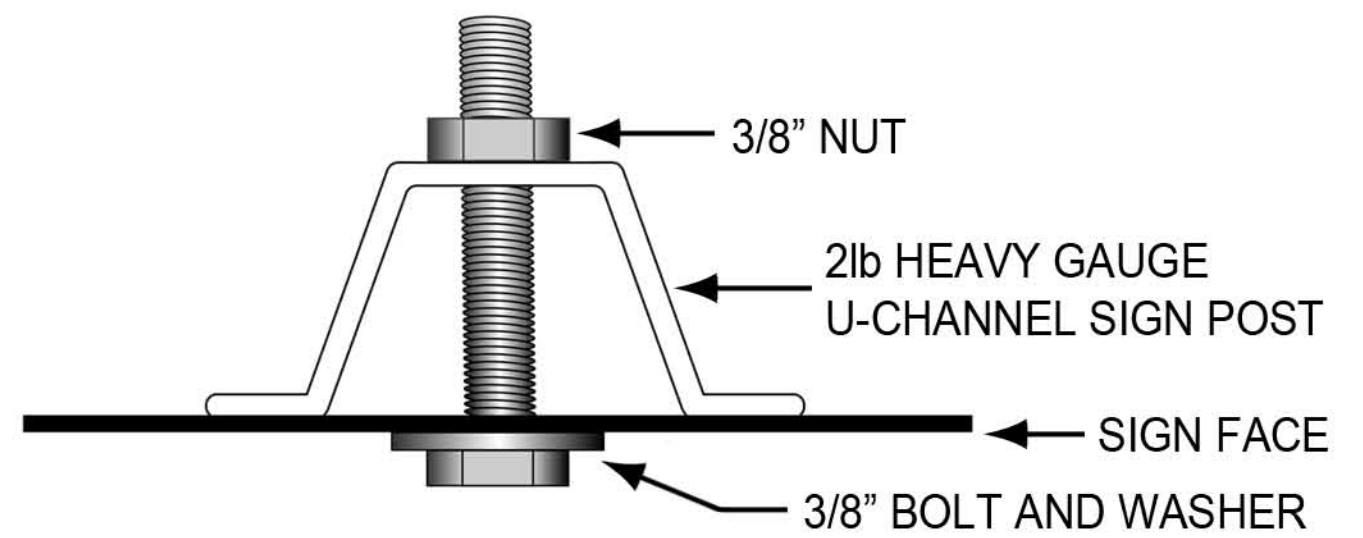

SIGN MOUNTING DETAIL

2.8m

12 ft LENGTH
2lb HEAVY GAUGE
U-CHANNEL SIGN POST

1.0m DEPTH
MIN. 300mm DIA.
25 MPA POURED IN PLACE CONCRETE FOOTING
DRY POUR REDI-MIX NOT ACCEPTABLE

FINISH GRADE

FINISH GRADE

THE CITY OF
SPRUCE GROVE

PLANNING AND INFRASTRUCTURE

REVISIONS		
DATE	DETAILS	DRAWN

SWMF SIGNAGE INSTALLATION



DRAWN: A. STACHNIAK DATE: NOVEMBER 23, 2020
 CHECKED: M. HUSSEY SCALE: NOT TO SCALE
 APPROVED: M. HUSSEY DRAWING No.: SN-05

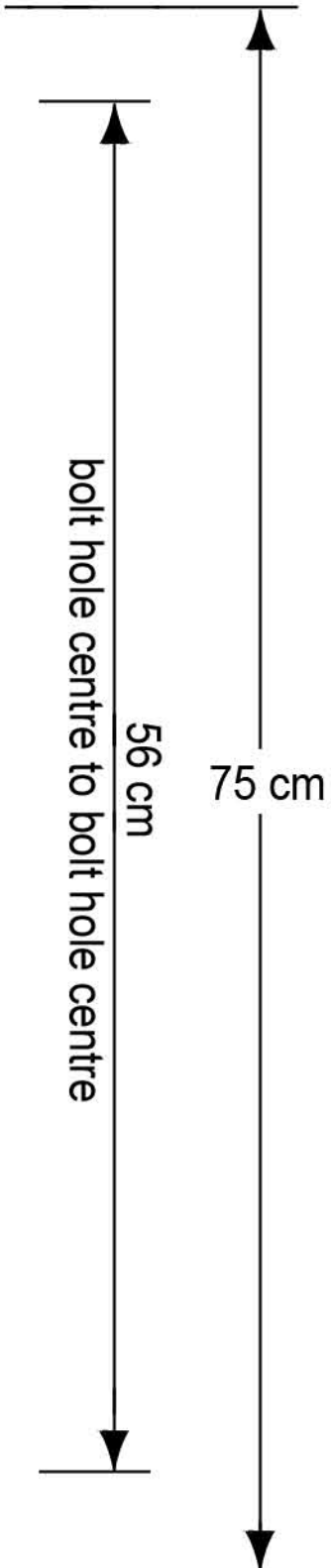

PROHIBITIVE SIGN SPECIFICATIONS:

BOLT HOLES TO BE 1cm IN DIAMETER TO ACCOMMODATE 3/8" BOLTS

0.08 ALUMINUM APPLIED WITH 3M DIAMOND GRADE WHITE REFLECTIVE SHEETING AND 8150 PRINT WITH OVERLAMINATE OR EQUIVALENT

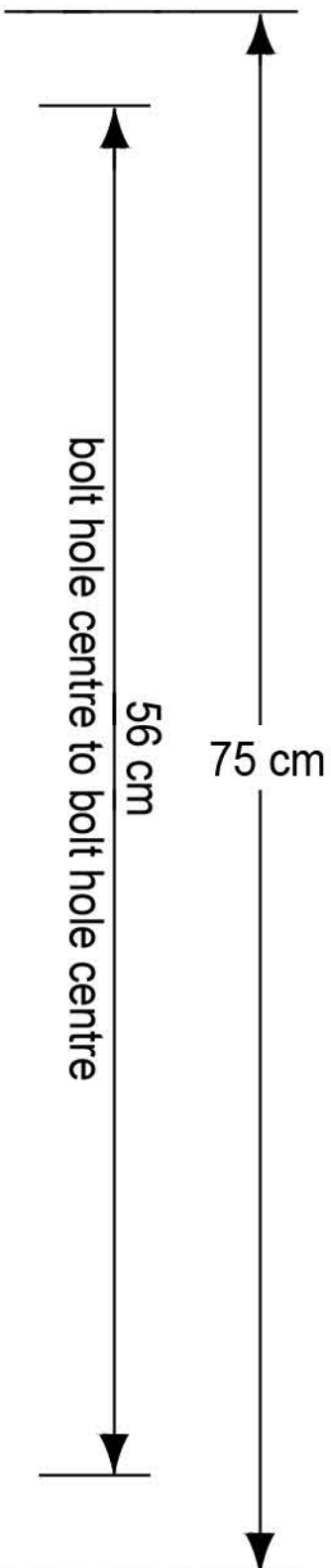

THE CITY OF SPRUCE GROVE

PLANNING AND INFRASTRUCTURE

REVISIONS		
DATE	DETAILS	DRAWN

PROHIBITIVE SWMF SIGNAGE



DRAWN: A. STACHNIAK	DATE: NOVEMBER 19, 2020
CHECKED: M. HUSSEY	SCALE: NOT TO SCALE
APPROVED: M. HUSSEY	DRAWING No.: SN-06



“DOG ON LEASH” SIGN SPECIFICATIONS:

BOLT HOLES TO BE 1cm IN DIAMETER TO ACCOMMODATE 3/8” BOLTS

0.08 ALUMINUM APPLIED WITH 3M DIAMOND GRADE WHITE REFLECTIVE SHEETING AND 1170 SERIES BLUE ELECTRO CUT GRAPHIC FILM OR EQUIVALENT

THE CITY OF
SPRUCE GROVE

PLANNING AND INFRASTRUCTURE

REVISIONS		
DATE	DETAILS	DRAWN

“DOG ON LEASH” SWMF SIGNAGE		
	DRAWN: A. STACHNIAK	DATE: NOVEMBER 19, 2020
	CHECKED: M. HUSSEY	SCALE: NOT TO SCALE
	APPROVED: M. HUSSEY	DRAWING No.: SN-07

ROUNDBABOUT

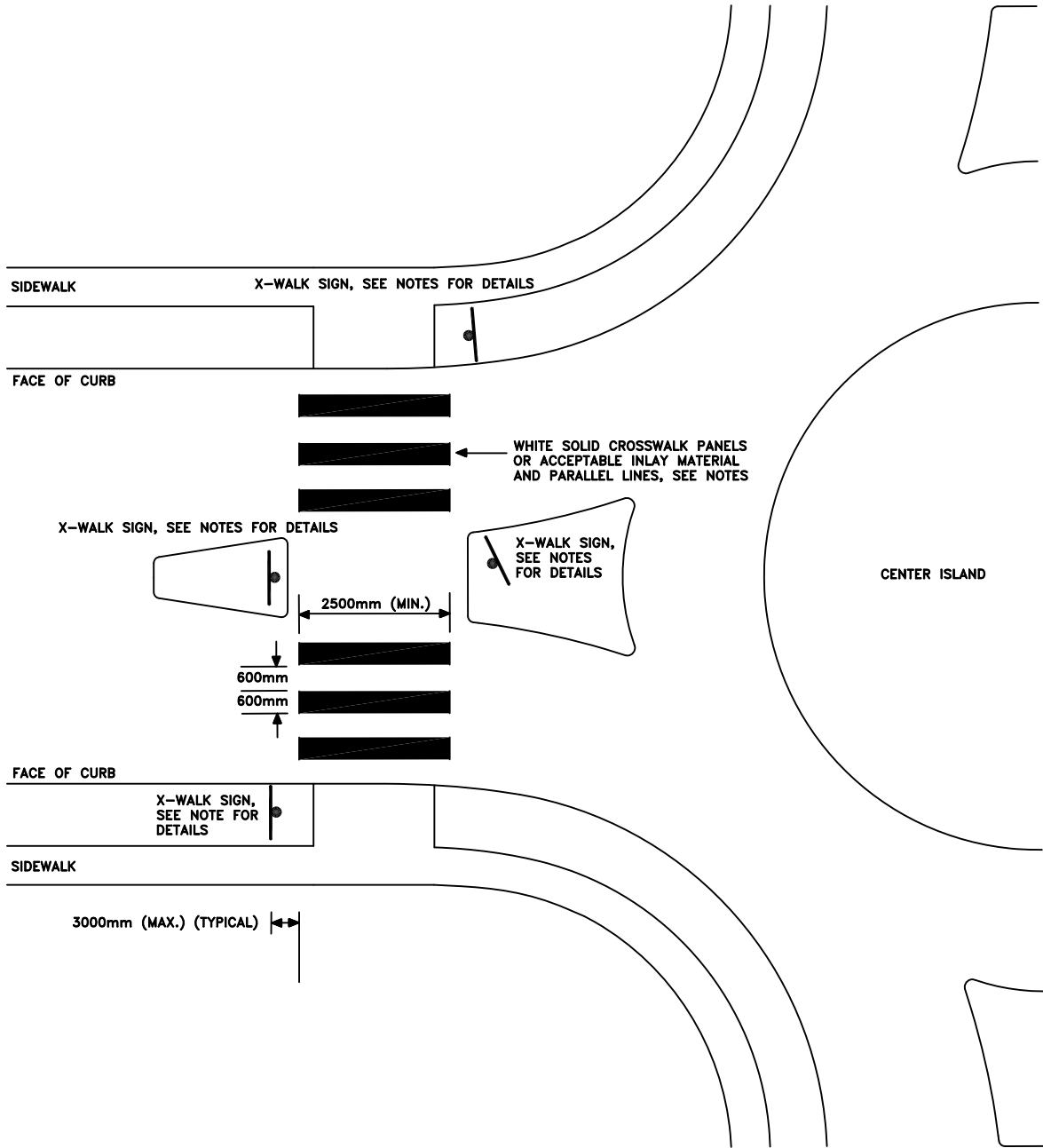

NOTES:

1. USE ZEBRA LINES OR ACCEPTABLE INLAY MATERIAL WITH PARALLEL LINES WHEN ONE OR MORE ROAD ENTERING THE ROUNDABOUT IS AN ARTERIAL OR COLLECTOR ROAD
2. USE PARALLEL LINES WHEN ALL ROADS ENTERING THE ROUNDABOUT ARE LOCAL ROADS
3. USE FLUORESCENT LIME YELLOW RA-3R/L SIGNS IN NON-SCHOOL AREA/ZONE
4. USE FLUORESCENT LIME YELLOW RA-4R/L SIGNS IN SCHOOL AREA/ZONE
5. ACCEPTABLE INLAY MATERIAL INCLUDES BRICK OR EQUIVALENT STAMPED COLORED CONCRETE
6. INLAY MATERIAL IS TO BE PLACED ON THE ENTIRE AREA BETWEEN THE CURB RAMP, ISLAND AND PARALLEL LINES

THE CITY OF
SPRUCE GROVE

PLANNING AND INFRASTRUCTURE

REVISIONS

DATE	DETAILS	DRAWN

PASSIVE CROSSWALK – ROUNDABOUTS



DRAWN: H. WHITE	DATE: JANUARY 11, 2021
CHECKED: D. FLYNN	SCALE: NOT TO SCALE
APPROVED: D. FLYNN	DRAWING No.: SN-08

XREFS

C:\DETAILS\SHEET2-TK

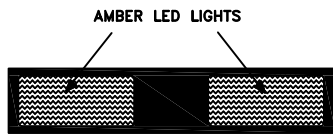
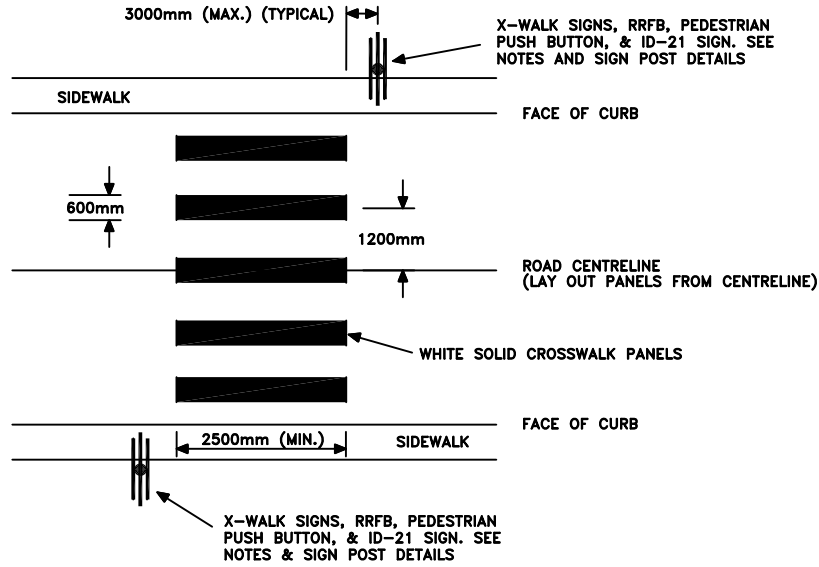

RRFB DETAIL

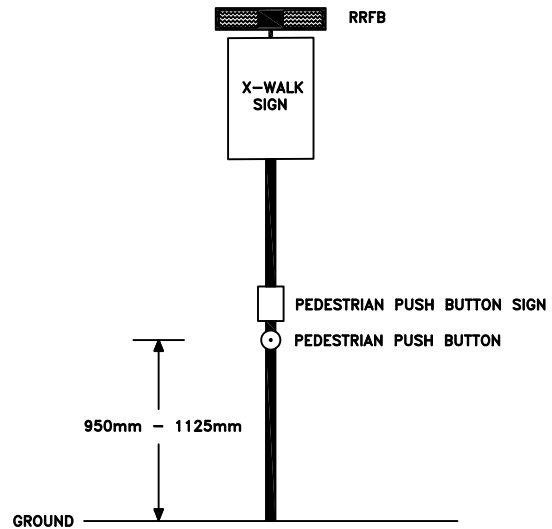

SIGN POST DETAIL

NOTES:

1. USE FLUORESCENT LIME YELLOW RA-3R/L SIGNS IN NON-SCHOOL AREA/ZONE
2. USE FLUORESCENT LIME YELLOW RA-4R/L SIGNS IN SCHOOL AREA/ZONE
3. MOUNT X-WALK SIGNS BACK-TO-BACK ON BOTH SIDES OF AN UNDIVIDED ROAD AND WHEN THE ROAD IS DIVIDED, MOUNT SINGLE SIDED ON THE RIGHT SIDE OF THE ROADS AND BACK-TO BACK ON THE MEDIAN
4. MOUNT RRFB DIRECTLY ABOVE X-WALK SIGN
5. MOUNT PEDESTRIAN PUSHBUTTON SIGN (ID-21) DIRECTLY ABOVE PEDESTRIAN PUSH BUTTON

THE CITY OF
SPRUCE GROVE

PLANNING AND INFRASTRUCTURE

REVISIONS

DATE	DETAILS	DRAWN

ACTIVE CROSSWALK – RRFB



DRAWN: H.WHITE	DATE: JANUARY 11, 2021
CHECKED: D. FLYNN	SCALE: NOT TO SCALE
APPROVED: D. FLYNN	DRAWING No.: SN-09

XREFS

C:\DETAILS\SHEET2-TK

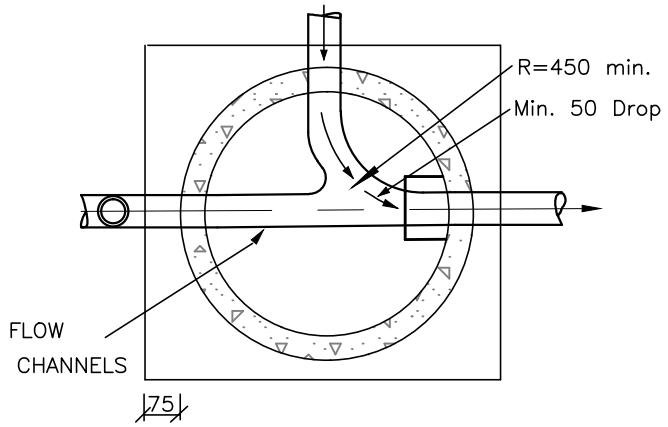
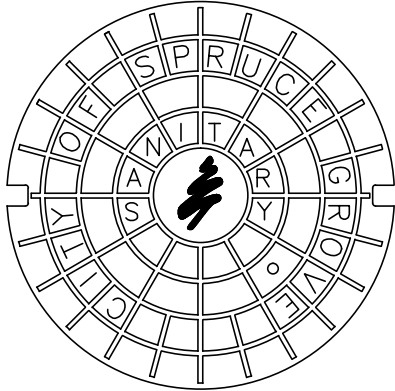

STANDARD FRAME & COVER

Use Norwood N.F.80 or Trojan T.F 80 on all manholes in roadways or walks (SEE DRAWING SY-05)

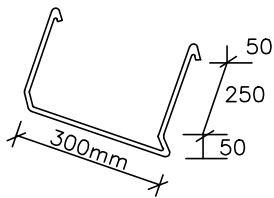

SAFETY TYPE M.H. RUNG

ALUMINUM SPACING TO BE 400mm CENTRE TO CENTRE

USE DURASEAL FOR WATERTIGHT COUPLING BETWEEN MH AND PVC PIPE

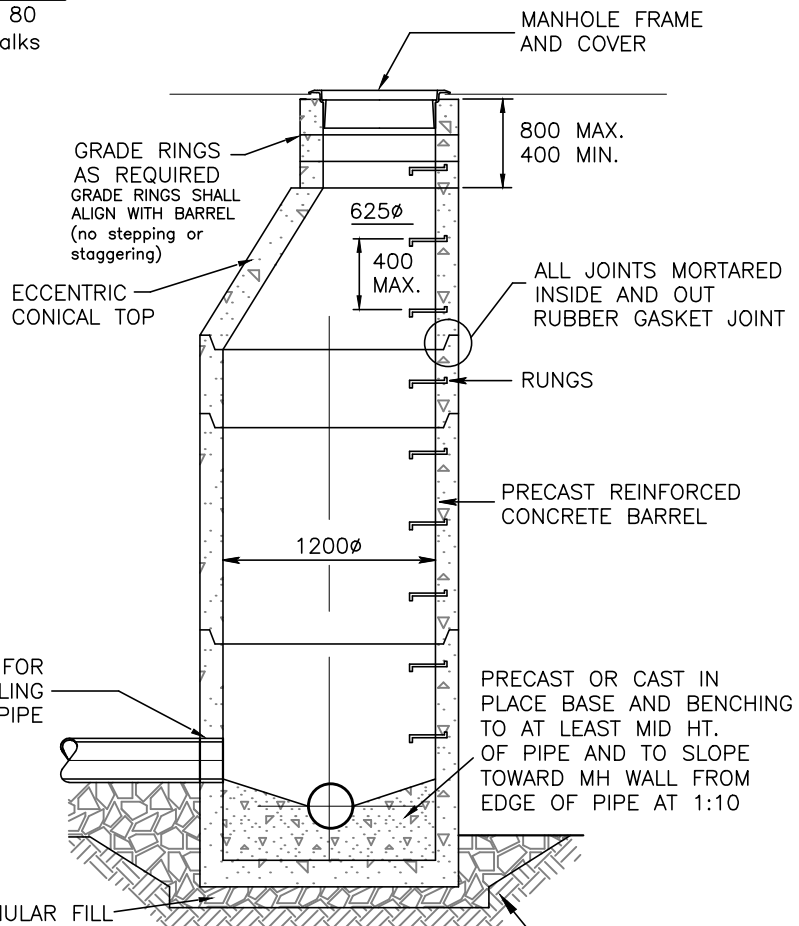

NOTES:

1. MANHOLES OF DEPTH GREATER THAN 7m REQUIRE AN ALUMINUM SAFETY PLATFORM.
2. ALL SEWER MAINS TYING INTO TRUNK MANHOLES MUST BE EXTENDED PAST CONCRETE SLAB SO THAT IT IS BOTH VISIBLE AND ACCESSIBLE FROM THE SURFACE.

XREFS

C:\DETAILS\SHEET2-TK

THE CITY OF
SPRUCE GROVE

PLANNING AND INFRASTRUCTURE

REVISIONS		
DATE	DETAILS	DRAWN
04/15	ADDITIONAL NOTES	RP

STANDARD SANITARY MANHOLE



DRAWN: T. CRAWFORD	DATE: MARCH 6, 2006
CHECKED: J. MUSTARD	SCALE: NOT TO SCALE
APPROVED: J. MUSTARD	DRAWING No.: SY-01

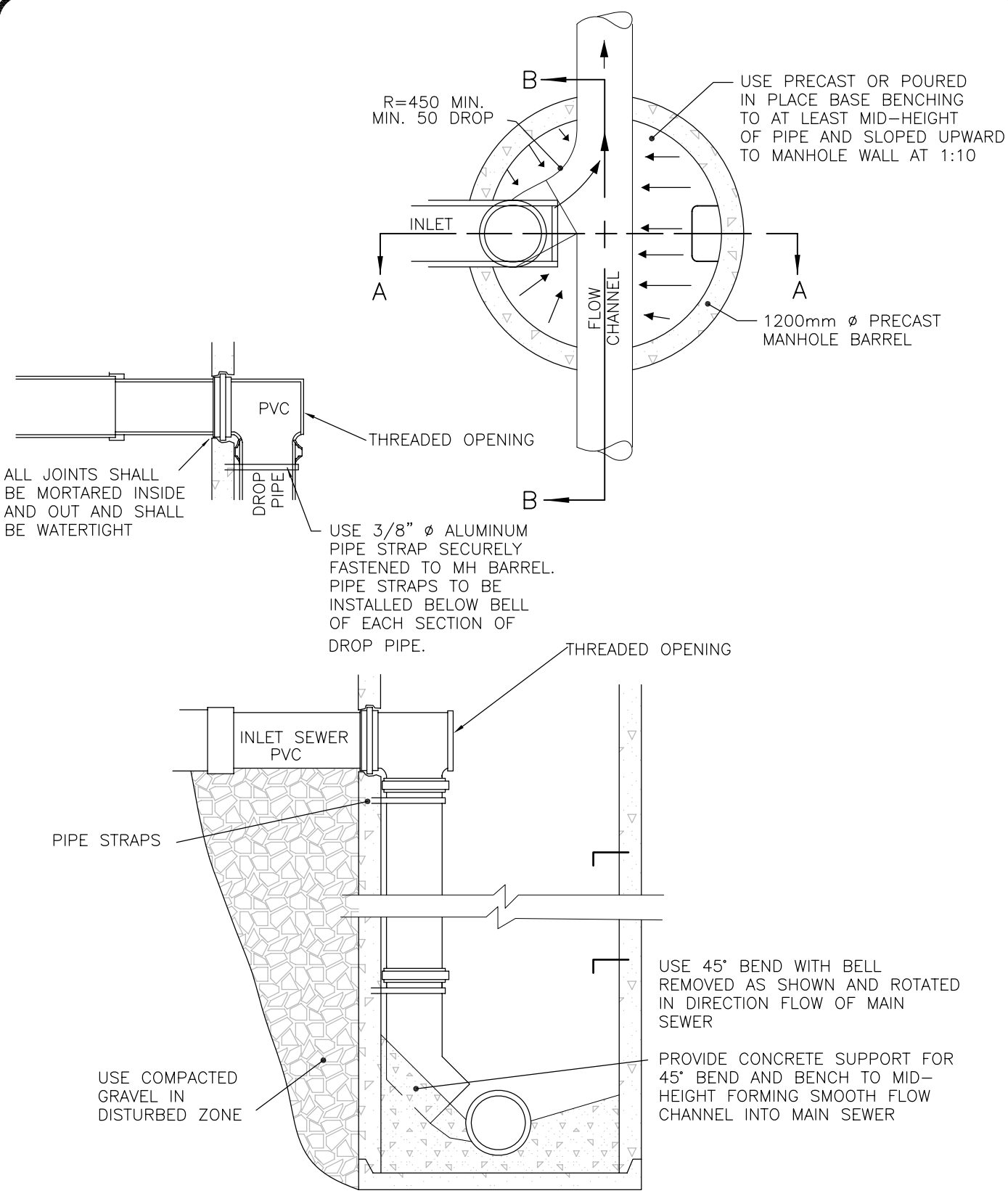

THE CITY OF
SPRUCE GROVE

PLANNING AND INFRASTRUCTURE

INTERIOR DROP MANHOLE

REVISIONS		
DATE	DETAILS	DRAWN



DRAWN: T. CRAWFORD	DATE: MARCH 6, 2006
CHECKED: J. MUSTARD	SCALE: NOT TO SCALE
APPROVED: J. MUSTARD	DRAWING No.: SY-02

XREFS

C:\DETAILS\SHEET2-TK

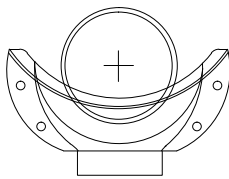

DROP BOWL MOUNTING POSITION

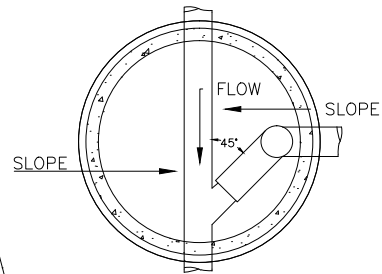

INSIDE DROP - PLAN

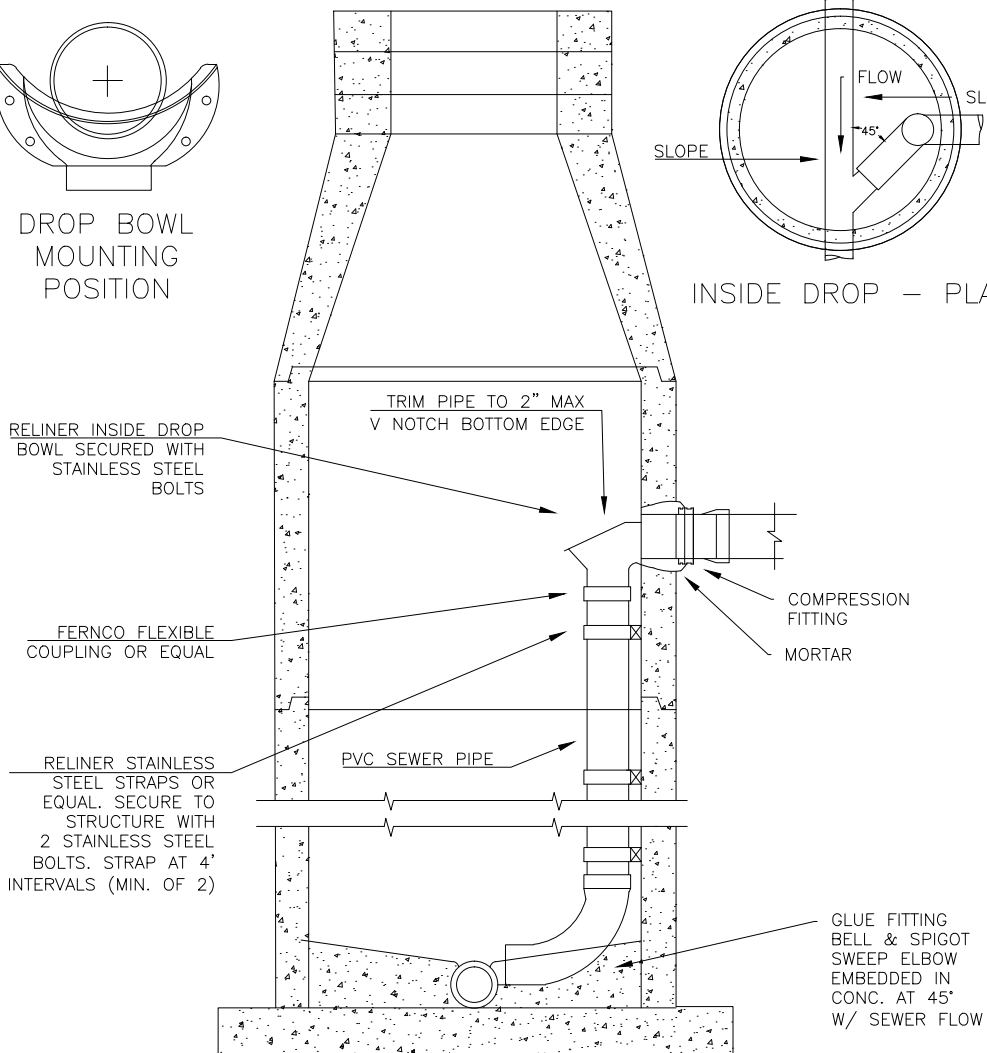

NOTES:

1. SECURE DROP PIPE TO MANHOLE WITH RELINER-DURAN INC. STAINLESS STEEL ADJUSTABLE CLAMPING BRACKETS.
2. FOR MORE INFORMATION ON DROP BOWL TYPES, SIZES AND BRACKETS, GO TO WWW.RELINER.COM

XREFS

C:\DETAILS\SHHEET2-TK

THE CITY OF
SPRUCE GROVE

PLANNING AND INFRASTRUCTURE

REVISIONS		
DATE	DETAILS	DRAWN

INTERIOR DROP MANHOLE - ALTERNATIVE



DRAWN: S.WILLIAMS	DATE: MARCH 7, 2014
CHECKED: J. MUSTARD	SCALE:
APPROVED: J. MUSTARD	DRAWING No.: SY-03

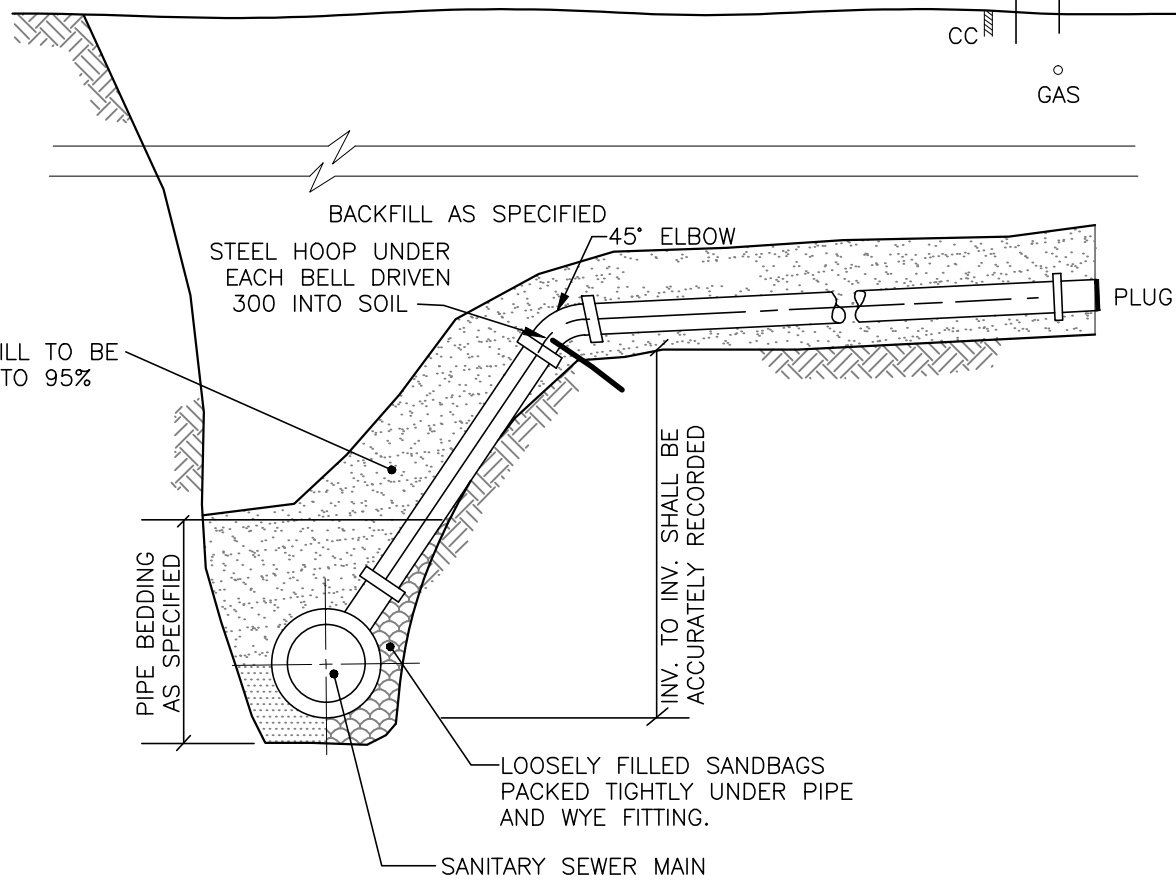
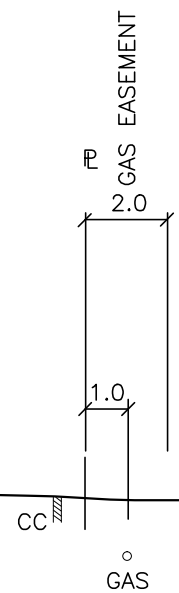
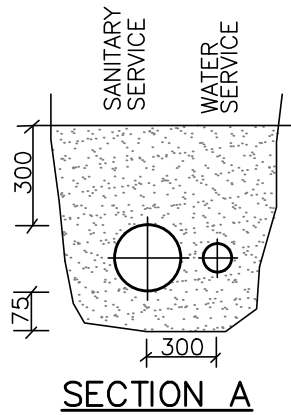

THE CITY OF
SPRUCE GROVE

PLANNING AND INFRASTRUCTURE

REVISIONS

DATE	DETAILS	DRAWN

SANITARY RISER



DRAWN: T. CRAWFORD	DATE: MARCH 6, 2006
CHECKED: J. MUSTARD	SCALE: NOT TO SCALE
APPROVED: J. MUSTARD	DRAWING No.: SY-04

XREFS

C:\DETAILS\SHEET2-TK

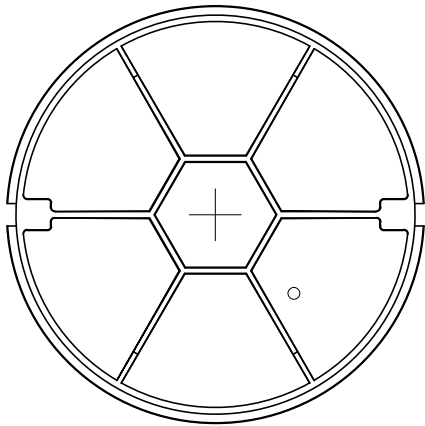

BOTTOM VIEW

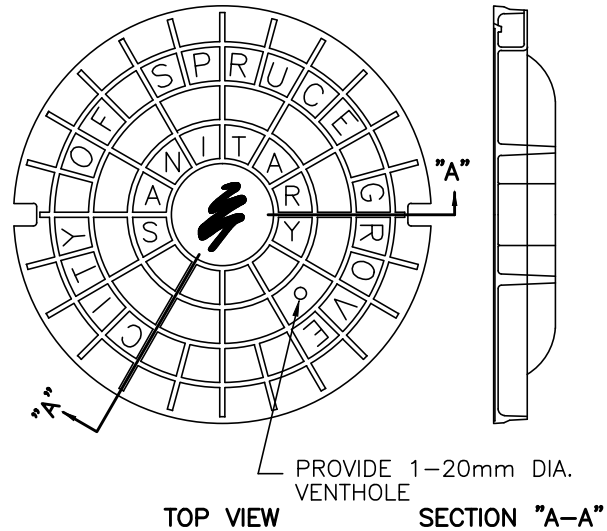

TOP VIEW

SECTION "A-A"

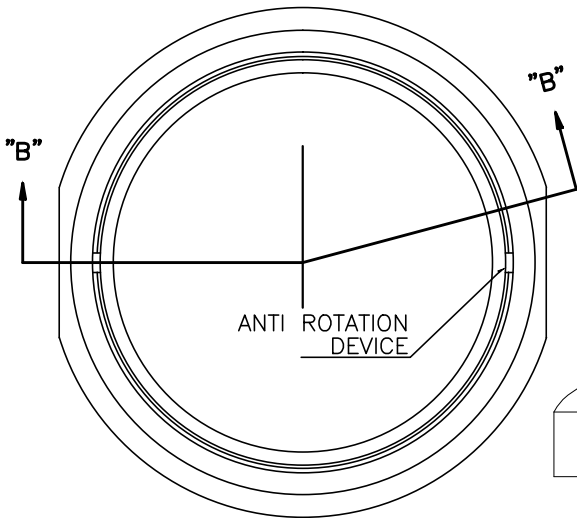

PLAN

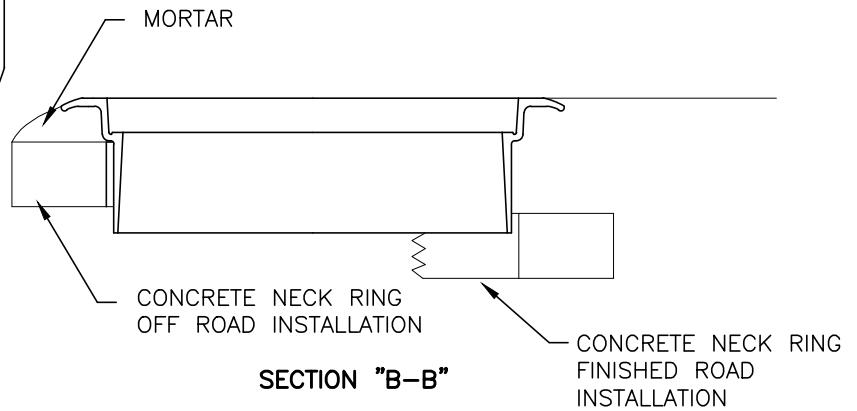

SECTION "B-B"

NOTES:

1. NORWOOD FOUNDRY TYPE NF80 OR TROJAN FOUNDRY TYPE TF80
2. GROUT TO BE INSTALLED BETWEEN FLANGE AND MANHOLE BARREL ON RAISED MANHOLES.
3. SINGLE HOLE IN MANHOLE COVER SHALL BE PLUGGED IN ALL LOW AREAS OR POTENTIAL PONDING AREAS.

THE CITY OF
SPRUCE GROVE

PLANNING AND INFRASTRUCTURE

XREFS

C:\DETAILS\SHEET2-TK

REVISIONS			NF/TF-80 FRAME AND COVER - SANITARY				
DATE	DETAILS	DRAWN		DRAWN:	DATE:		
04/15	ADDITIONAL NOTES	RP		CHECKED:	J. MUSTARD	SCALE:	NOT TO SCALE
				APPROVED:	J. MUSTARD	DRAWING No.:	SY-05

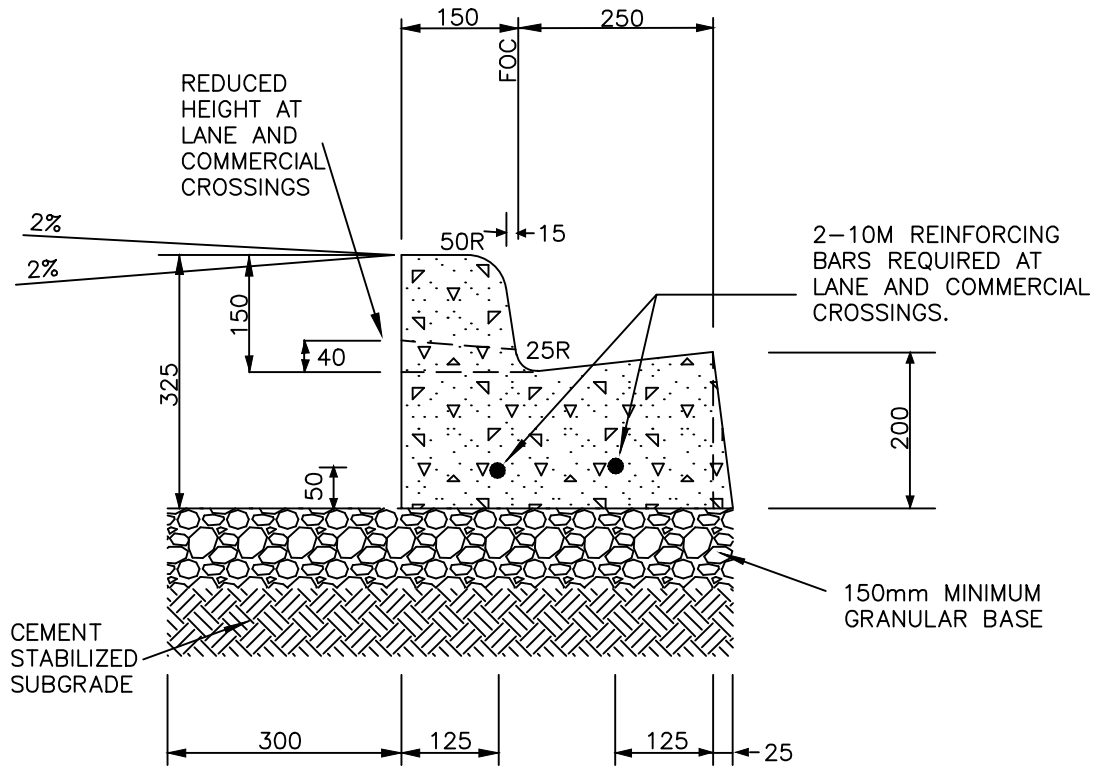

NOTES:

1. ALL DIMENSIONS ARE IN MILLIMETERS UNLESS OTHERWISE INDICATED.

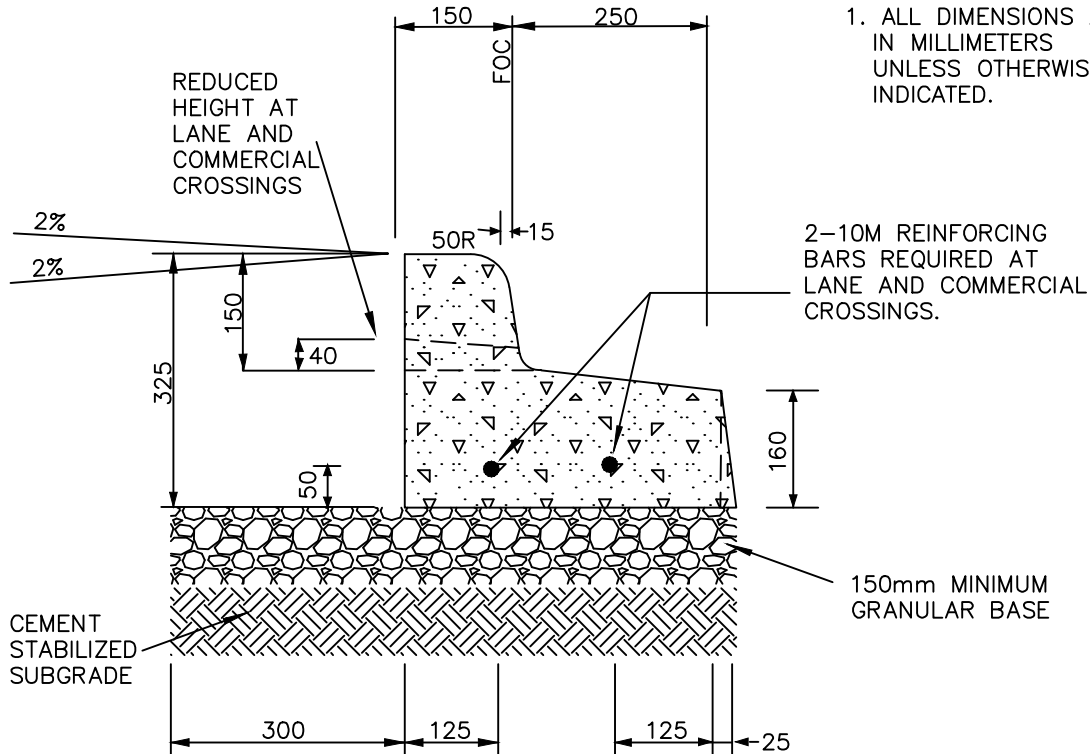

XREFS

C:\DETAILS\SHEET2-TK

THE CITY OF
SPRUCE GROVE

PLANNING AND INFRASTRUCTURE

REVISIONS

DATE	DETAILS	DRAWN
03/13	GRANULAR BASE	SW
09/20	STANDARDS UPDATE	WSP

STANDARD CURB & GUTTER



DRAWN: T. CRAWFORD
 CHECKED: J. MUSTARD
 APPROVED: J. MUSTARD

DATE: MARCH 6, 2006
 SCALE: NOT TO SCALE
 DRAWING No.: TN-01

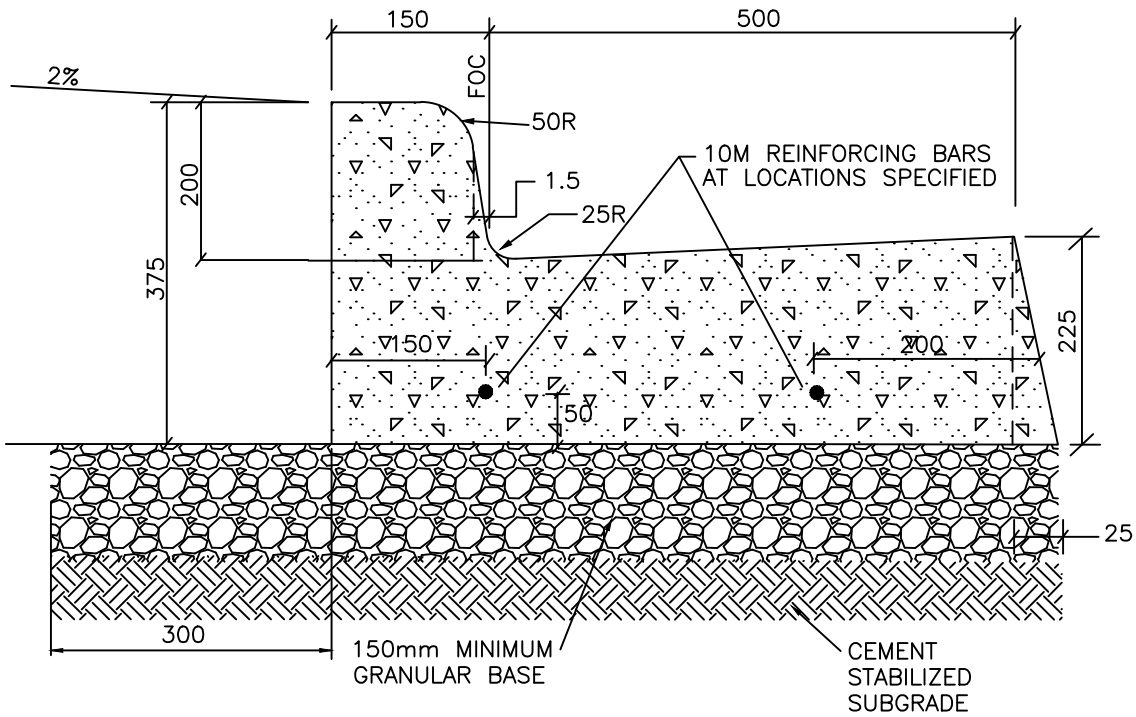

NOTES:

1. ALL DIMENSIONS ARE IN MILLIMETERS UNLESS OTHERWISE INDICATED.

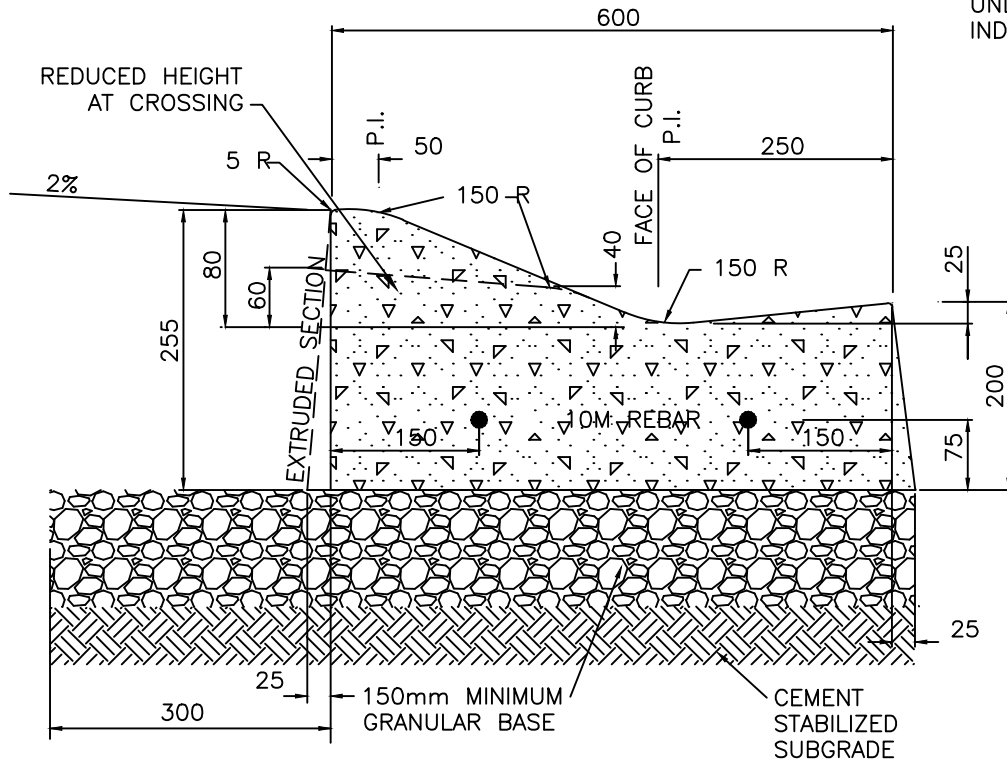

XREFS

C:\DETAILS\SHEET2-TK

THE CITY OF
SPRUCE GROVE

PLANNING AND INFRASTRUCTURE

REVISIONS		
DATE	DETAILS	DRAWN
03/13	GRANULAR BASE	SW
09/20	STANDARDS UPDATE	WPS



STD. ARTERIAL CURB AND GUTTER ROLLED CURB AND GUTTER

DRAWN: T. CRAWFORD	DATE: MARCH 6, 2006
CHECKED: J. MUSTARD	SCALE: NOT TO SCALE
APPROVED: J. MUSTARD	DRAWING No.: TN-02

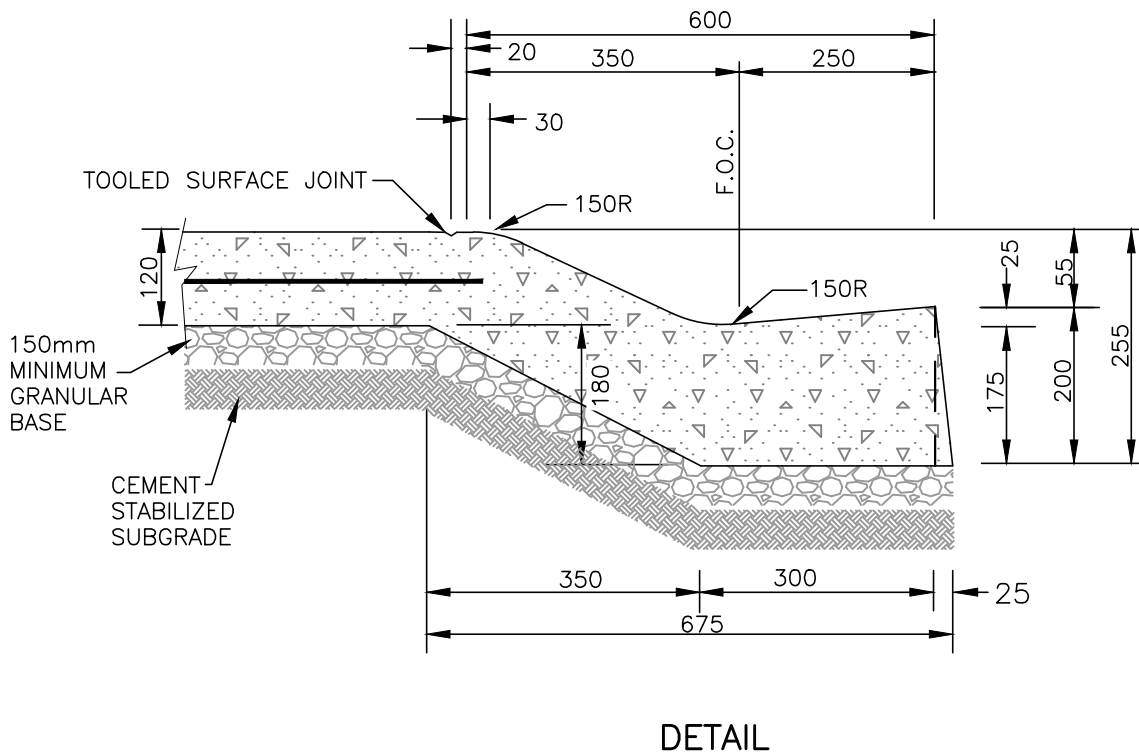
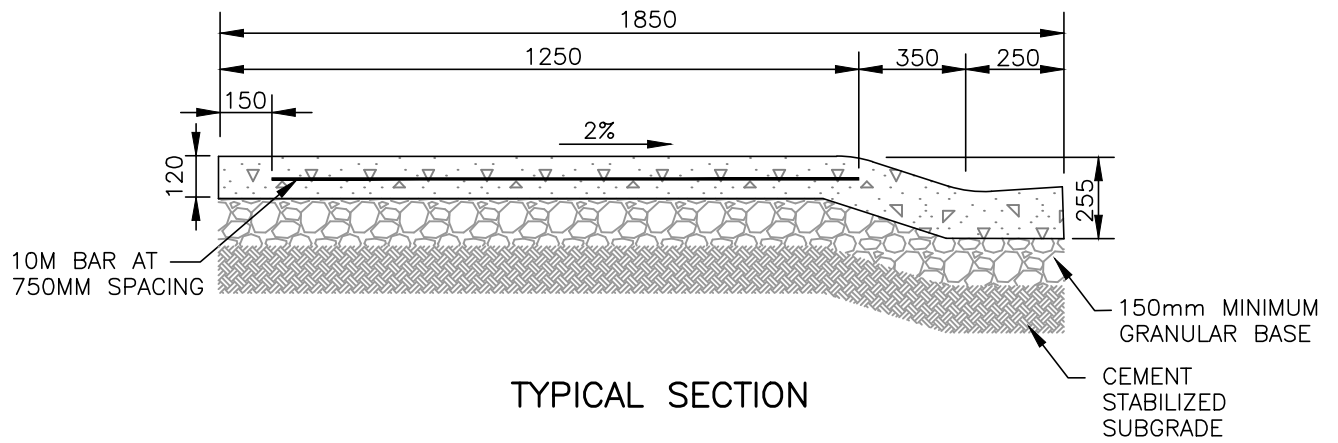

XREFS

C:\DETAILS\SHEET2-TK

THE CITY OF
SPRUCE GROVE

PLANNING AND INFRASTRUCTURE

REVISIONS		
DATE	DETAILS	DRAWN
03/13	GRANULAR BASE	SW

ROLLED MONO CURB & GUTTER

	DRAWN: T. CRAWFORD	DATE: MARCH 6, 2006
	CHECKED: J. MUSTARD	SCALE: NOT TO SCALE
	APPROVED: J. MUSTARD	DRAWING No.: TN-03

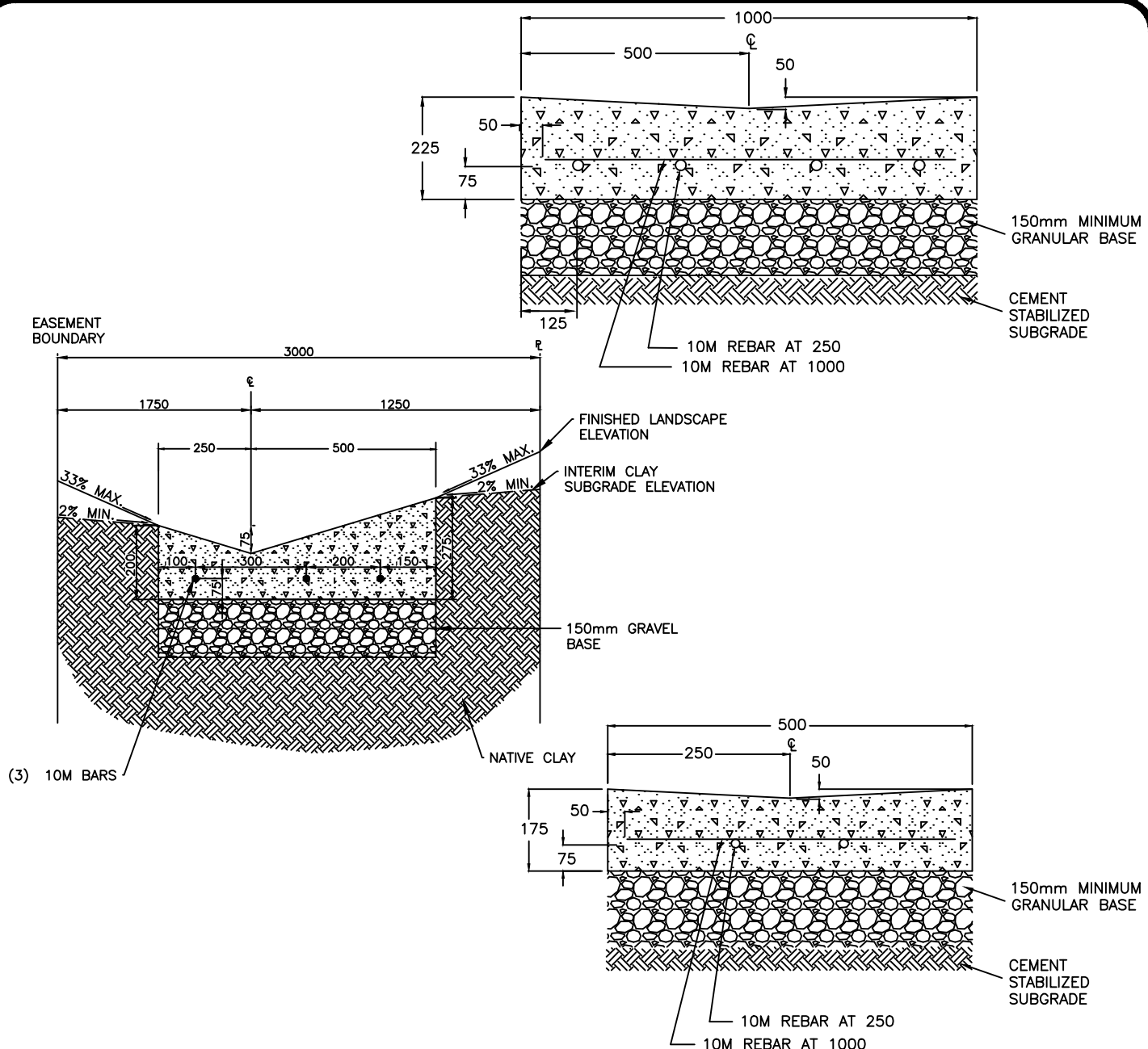

NOTES:

- C SWALE TO MATCH GUTTER ELEVATION AT UPSTREAM END. LOWER GUTTER LIP TO MEET SWALE EDGE.
- SWALE EDGE TO MATCH GUTTER ELEVATION IN DOWNSTREAM END. LOWER GUTTER LIP TO MATCH C OF SWALE.
- EXPANSION JOINTS TO BE CONSTRUCTED AT ENDS OF SWALE WHERE SWALE ABUTS GUTTERS.
- CONTRACTION JOINTS 50 DEEP AND 5 WIDE TO BE CONSTRUCTED 3m ON CENTERS ALONG SWALE.
- CROWN OF ROAD TO BE TAPERED, STARTING 15m FROM SWALE, TO PROVIDE SMOOTH VEHICULAR CROSSING OF SWALE.
- MINIMUM GRADE - 0.6%
- CONCRETE SWALE TO BE USED WHEN ASPHALT GRADE IS LESS THAN 1%

THE CITY OF
SPRUCE GROVE

PLANNING AND INFRASTRUCTURE

REVISIONS

DATE	DETAILS	DRAWN
4/12	Rev. CL depth	RP
3/13	GRANULAR BASE	SW
2/22	Standards Update	

CONCRETE SWALE



DRAWN: T. CRAWFORD	DATE: FEBRUARY 18, 2022
CHECKED: J. MUSTARD	SCALE: NOT TO SCALE
APPROVED: J. MUSTARD	DRAWING No.: TN-04

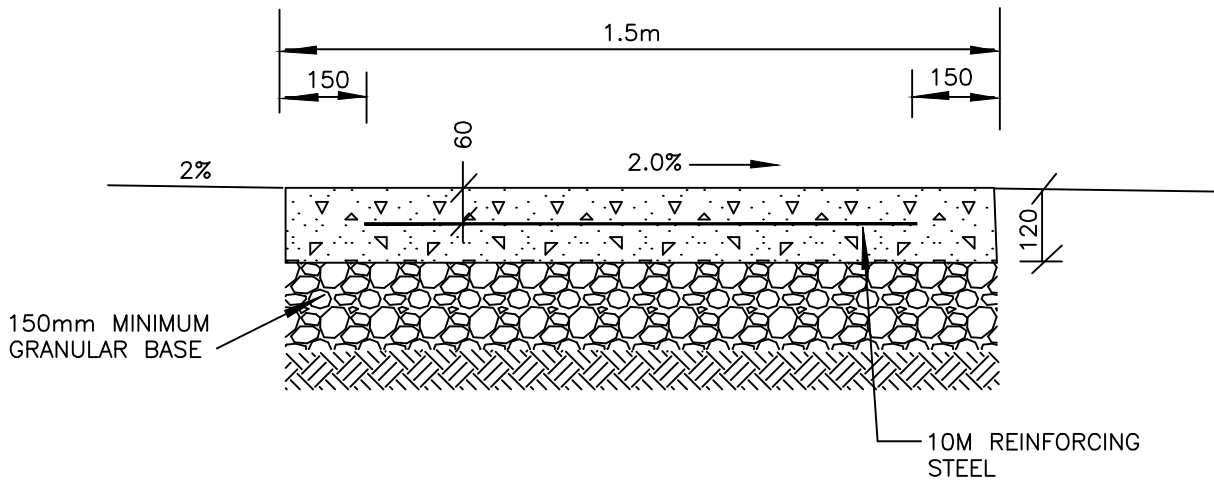
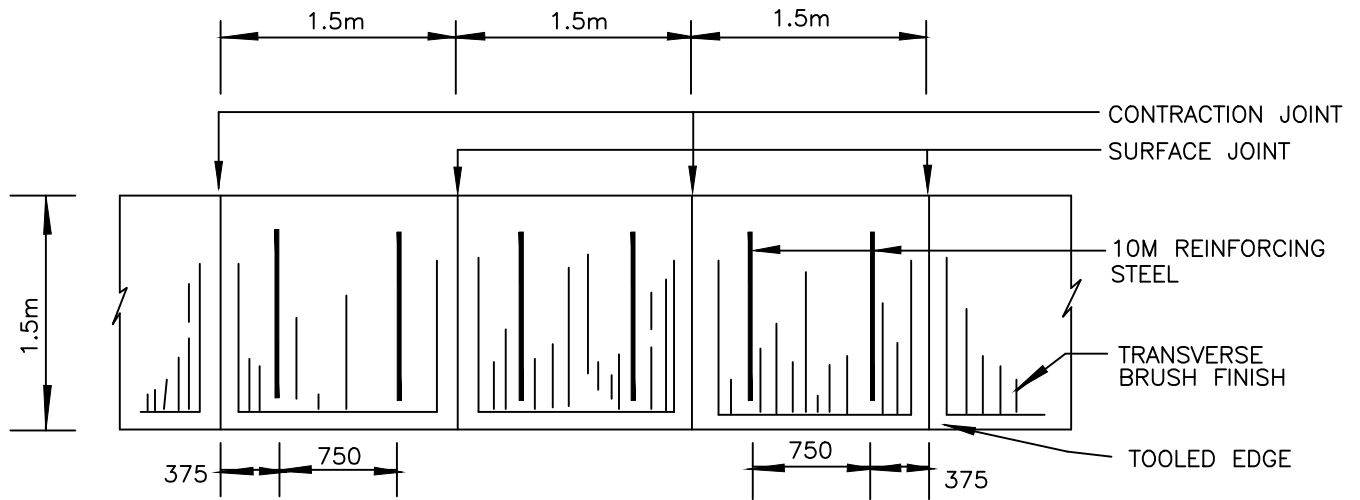

THE CITY OF
SPRUCE GROVE

PLANNING AND INFRASTRUCTURE

REVISIONS

DATE	DETAILS	DRAWN
03/13	GRANULAR BASE	SW
2/22	Standards Update	

SEPERATE SIDEWALK



DRAWN: T. CRAWFORD	DATE: FEBRUARY 10, 2022
CHECKED: J. MUSTARD	SCALE: NOT TO SCALE
APPROVED: J. MUSTARD	DRAWING No.: TN-05

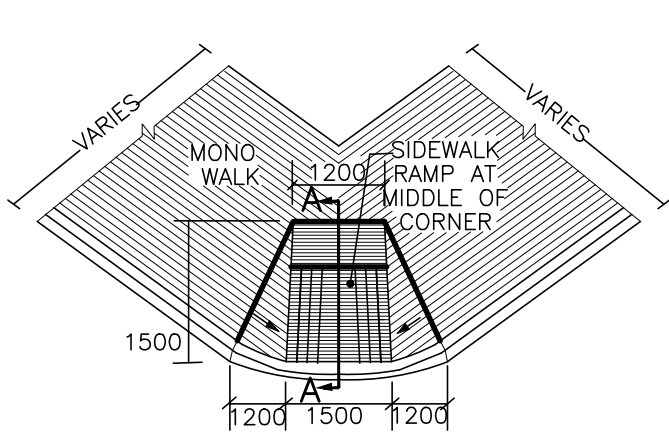

TYPE A

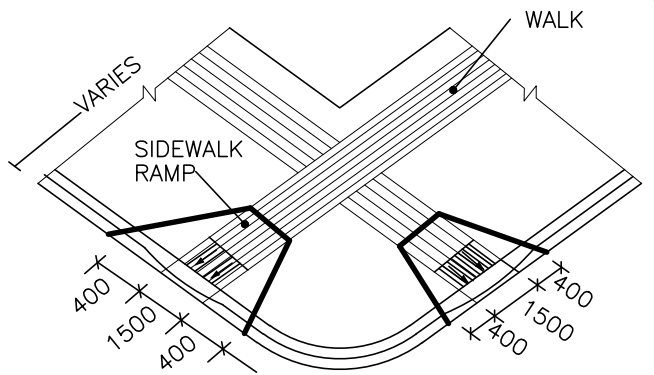

TYPE B

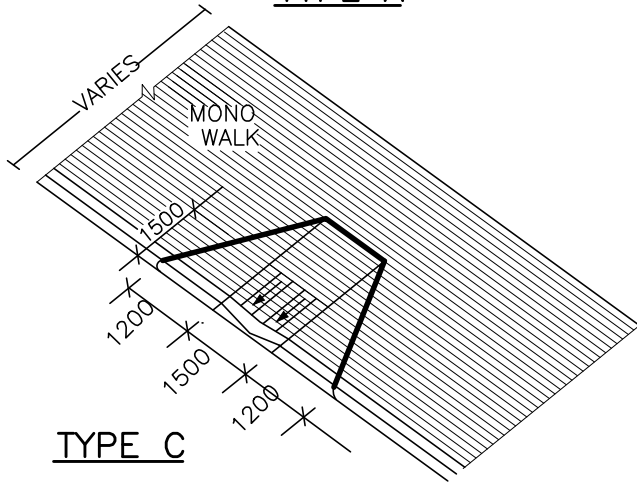

TYPE C

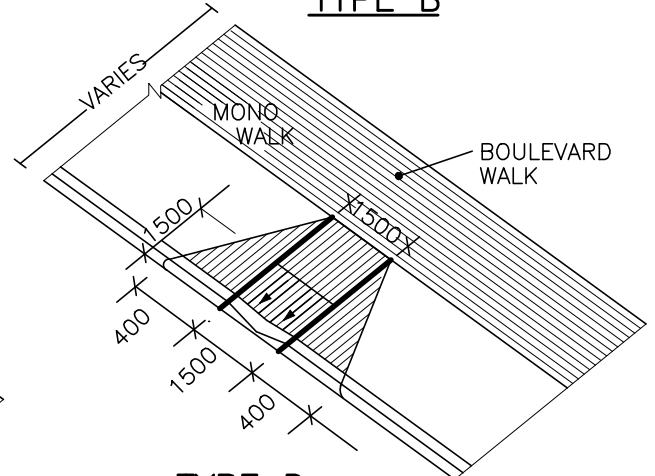

TYPE D

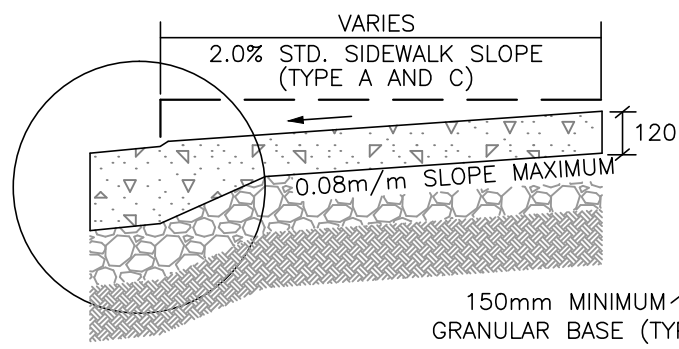

TYPICAL CROSS-SECTION A-A

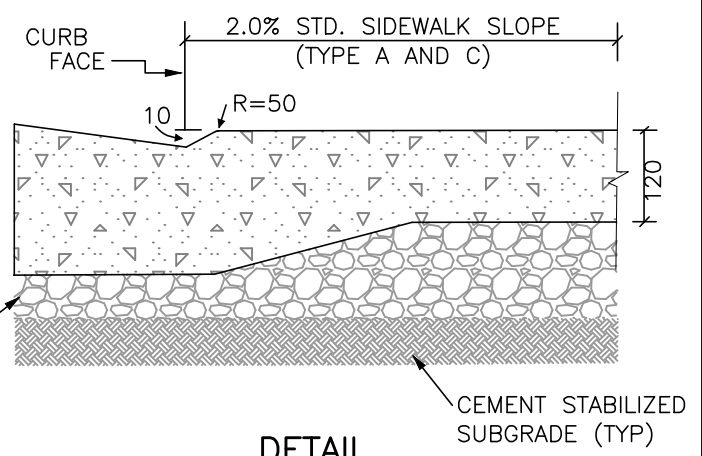

DETAIL

NOTES:

1. TOOLED GROOVES 5mm WIDE X 10mm DEEP, BROOM FINISH GROOVE SPACING 150mm O.C. ADJACENT TO CURB.
2. WHERE RAMP IS TO BE USED AS A TRANSITION, USE THE CENTRE OF THE 150mm RAMP AS THE CENTRE OF THE TRANSITION.
3. WHERE CURB FACE IS 200mm, DISTANCE OF FLARE SHOULD BE 1600mm.
4. CURBS AND RAMPS TO BE POURED MONOLITHICALLY.
5. 150mm MINIMUM GRAVEL UNDER ALL CONCRETE STRUCTURES.

THE CITY OF
SPRUCE GROVE

PLANNING AND INFRASTRUCTURE

REVISIONS

DATE	DETAILS	DRAWN
03/13	GRANULAR BASE	SW

PARA RAMP DETAILS

	DRAWN: T. CRAWFORD	DATE: MARCH 6, 2006
	CHECKED: J. MUSTARD	SCALE: NOT TO SCALE
	APPROVED: J. MUSTARD	DRAWING No.: TN-06

XREFS

C:\DETAILS\SHEET2-TK

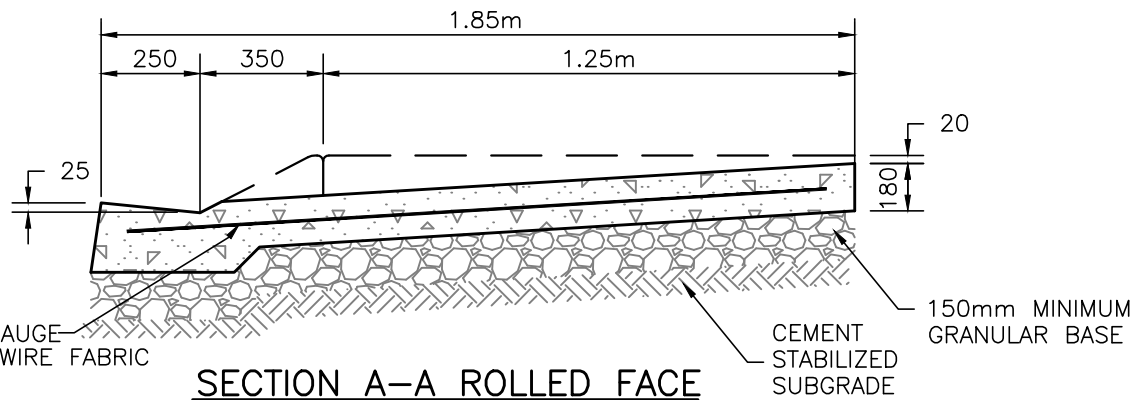
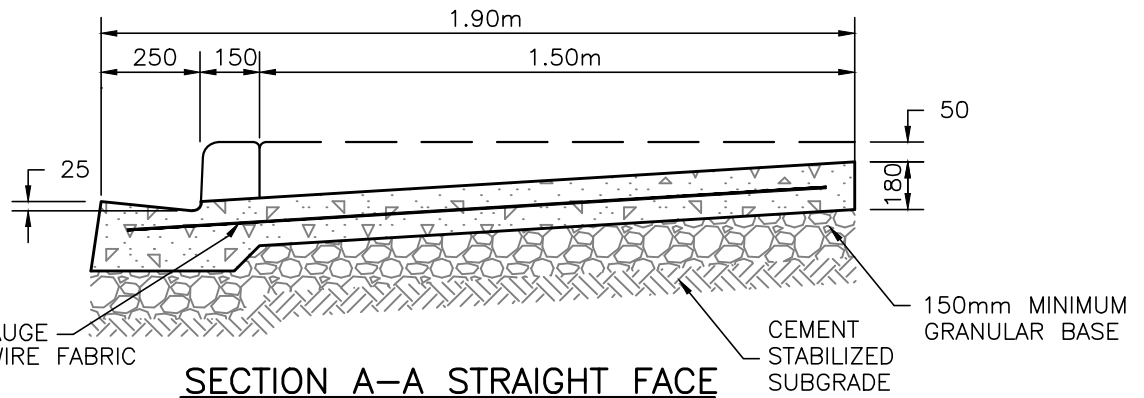
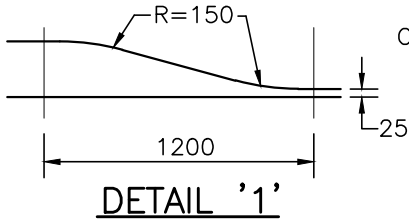
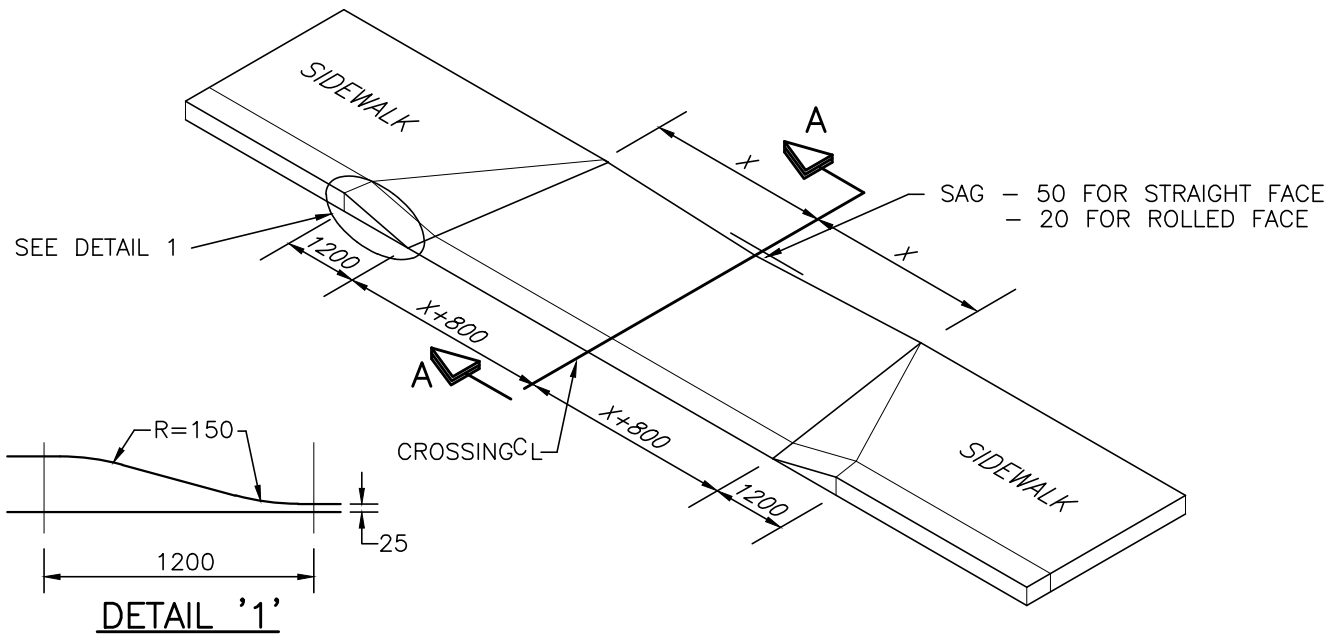

NOTES:

1. MAXIMUM SLOPE 8% UNLESS OTHERWISE APPROVED BY ENGINEER.
2. CROSSING TO BE POURED MONOLITHICALLY WITH CURB AND GUTTER.
3. BACK OF CROSSING DROP FOR EXISTING 200mm CURBFACE IS 100mm.
4. ALL DIMENSIONS IN MILLIMETRES UNLESS OTHERWISE SHOWN.

THE CITY OF
SPRUCE GROVE

PLANNING AND INFRASTRUCTURE

REVISIONS

DATE	DETAILS	DRAWN
03/13	GRANULAR BASE	SW

COMMERCIAL/LANE CROSSINGS



DRAWN: T. CRAWFORD	DATE: MARCH 6, 2006
CHECKED: J. MUSTARD	SCALE: NOT TO SCALE
APPROVED: J. MUSTARD	DRAWING No.: TN-07

XREFS

C:\DETAILS\SHEET2-TK

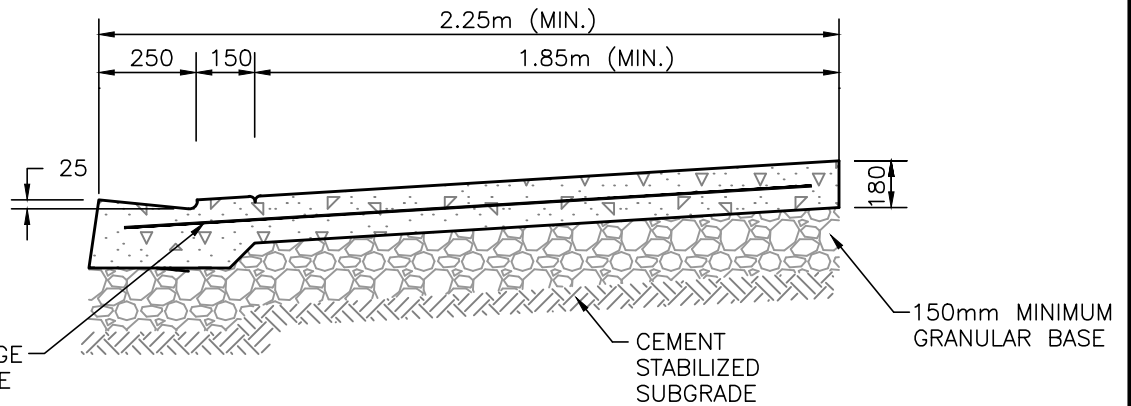
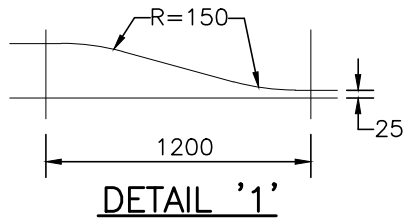
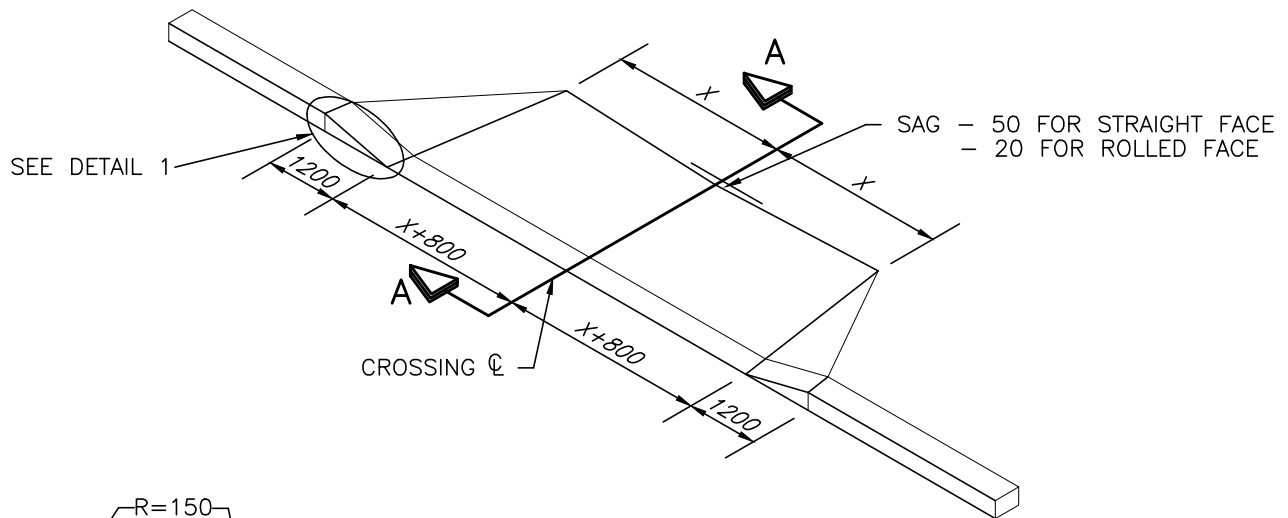

SECTION A-A

NOTES:

1. MAXIMUM SLOPE 8% UNLESS OTHERWISE APPROVED BY ENGINEER.

THE CITY OF
SPRUCE GROVE

PLANNING AND INFRASTRUCTURE

REVISIONS

DATE	DETAILS	DRAWN
03/13	GRANULAR BASE	SW

COMMERCIAL CROSSING



DRAWN: T. CRAWFORD	DATE: MARCH 6, 2006
CHECKED: J. MUSTARD	SCALE: NOT TO SCALE
APPROVED: J. MUSTARD	DRAWING No.: TN-08

XREFS

C:\DETAILS\SHEET2-TK

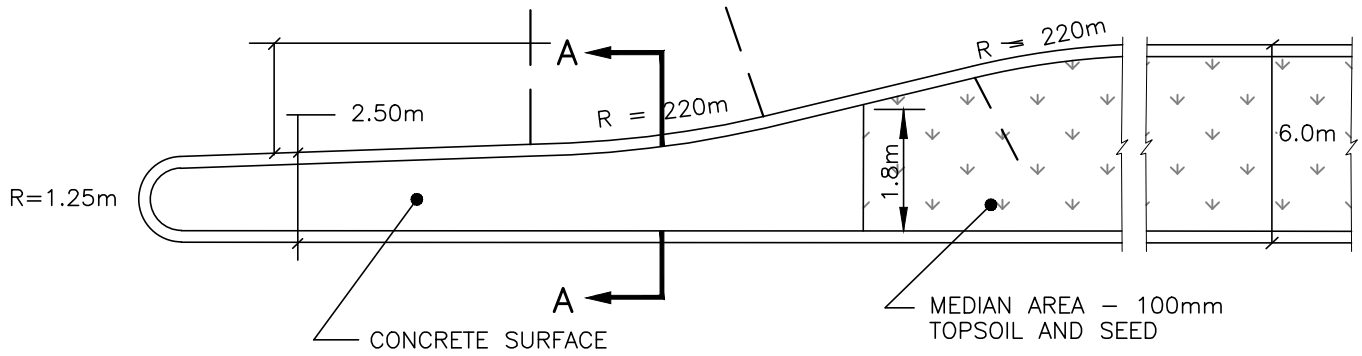

NOTE: MEDIANS AND ISLANDS TO BE CROWNED OR SLOPED TO PROVIDE DRAINAGE TO GUTTER.

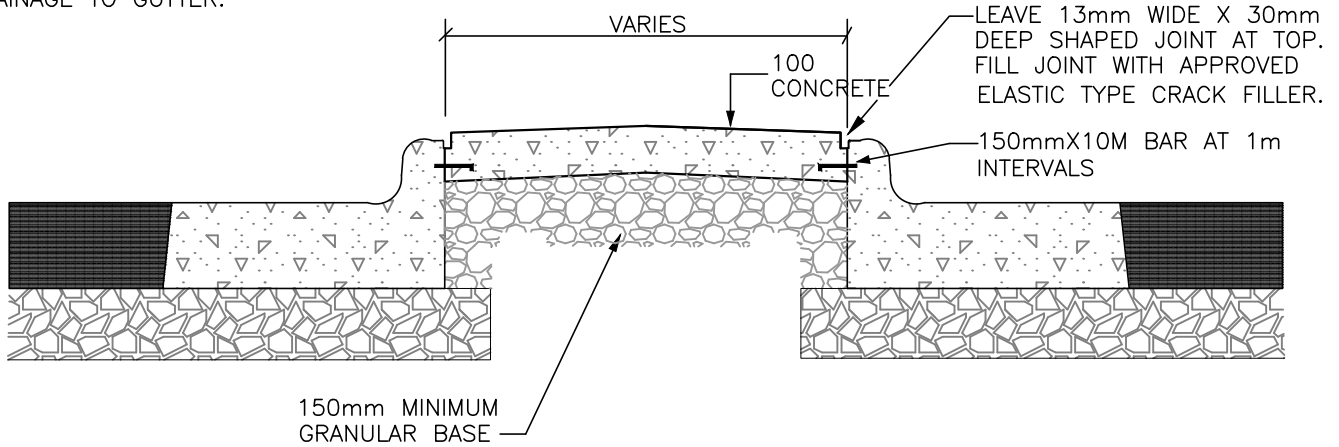

SECTION A-A

THE CITY OF
SPRUCE GROVE

PLANNING AND INFRASTRUCTURE

REVISIONS

DATE	DETAILS	DRAWN
03/13	GRANULAR BASE	SW

TYPICAL MEDIAN



DRAWN: T. CRAWFORD	DATE: MARCH 6, 2006
CHECKED: J. MUSTARD	SCALE: NOT TO SCALE
APPROVED: J. MUSTARD	DRAWING No.: TN-09

DEPTH OF
TOP LIFT
DEFERRED

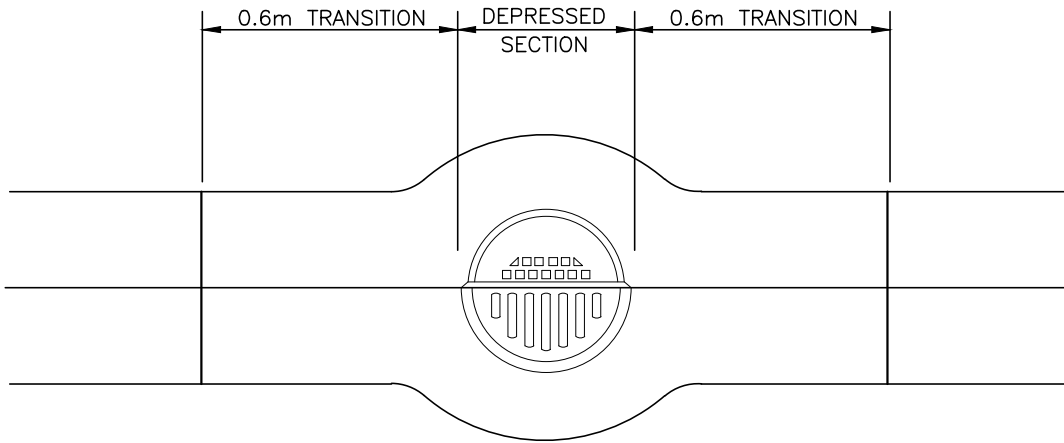
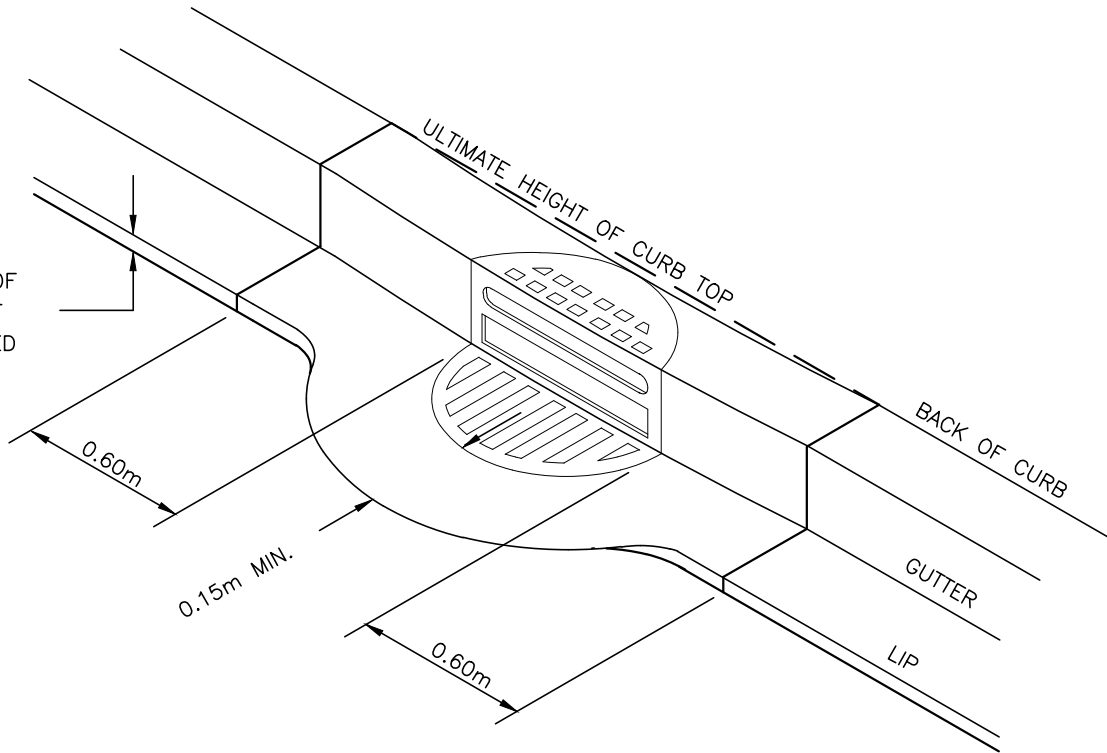

PLAN VIEW

- NOTES:
1. TYPICAL CURB & GUTTER TREATMENT AT CATCH BASIN WHEN ASPHALT TOP LIFT IS DEFERRED.
LOCATION TO BE DETERMINED BY ENGINEER.

XREFS

C:\DETAILS\SHEET2-TK

THE CITY OF
SPRUCE GROVE

PLANNING AND INFRASTRUCTURE

REVISIONS

DATE	DETAILS	DRAWN
4/12	Drawing Number	RP

DEPRESSED CURB & GUTTER



DRAWN: T. CRAWFORD	DATE: MARCH 6, 2006
CHECKED: J. MUSTARD	SCALE: NOT TO SCALE
APPROVED: J. MUSTARD	DRAWING No.: TN-10

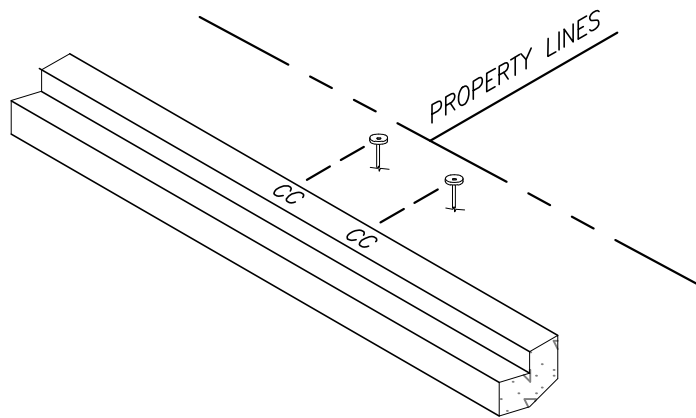
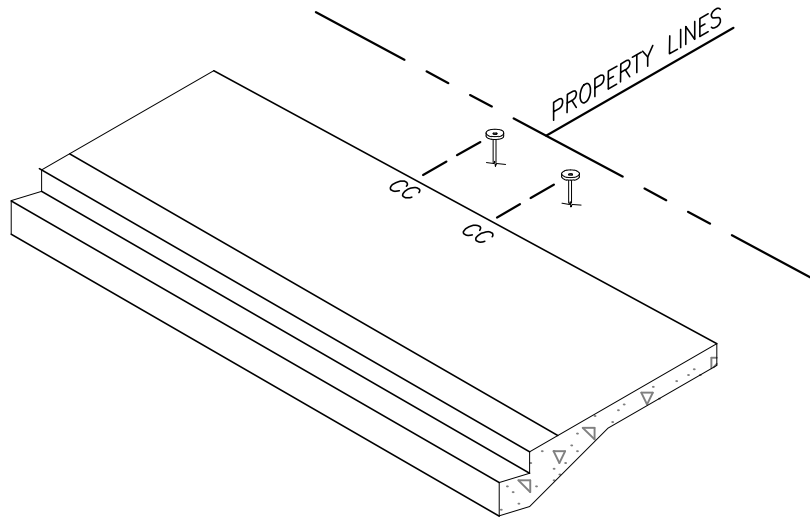

NOTE:

SERVICE BOXES SHALL BE SET VERTICAL - 150mm ABOVE THE SIDEWALK/CURB ELEVATION WHEN THE SERVICE BOX IS IN THE EXTENDED POSITION. AT THE TIME OF SIDEWALK/CURB CONSTRUCTION THE LETTERS "CC" SHALL BE NEATLY MARKED INTO THE MOIST CONCRETE DIRECTLY OPPOSITE EACH SERVICE BOX.

THE CITY OF
SPRUCE GROVE

PLANNING AND INFRASTRUCTURE

XREFS

C:\DETAILS\SHEET2-TK

REVISIONS			"CC" STAMP	
DATE	DETAILS	DRAWN	DRAWN:	DATE:
4/12	Drawing Number	RP	T. CRAWFORD	MARCH 6, 2006
			CHECKED: J. MUSTARD	SCALE: NOT TO SCALE
			APPROVED: J. MUSTARD	DRAWING No.: TN-11



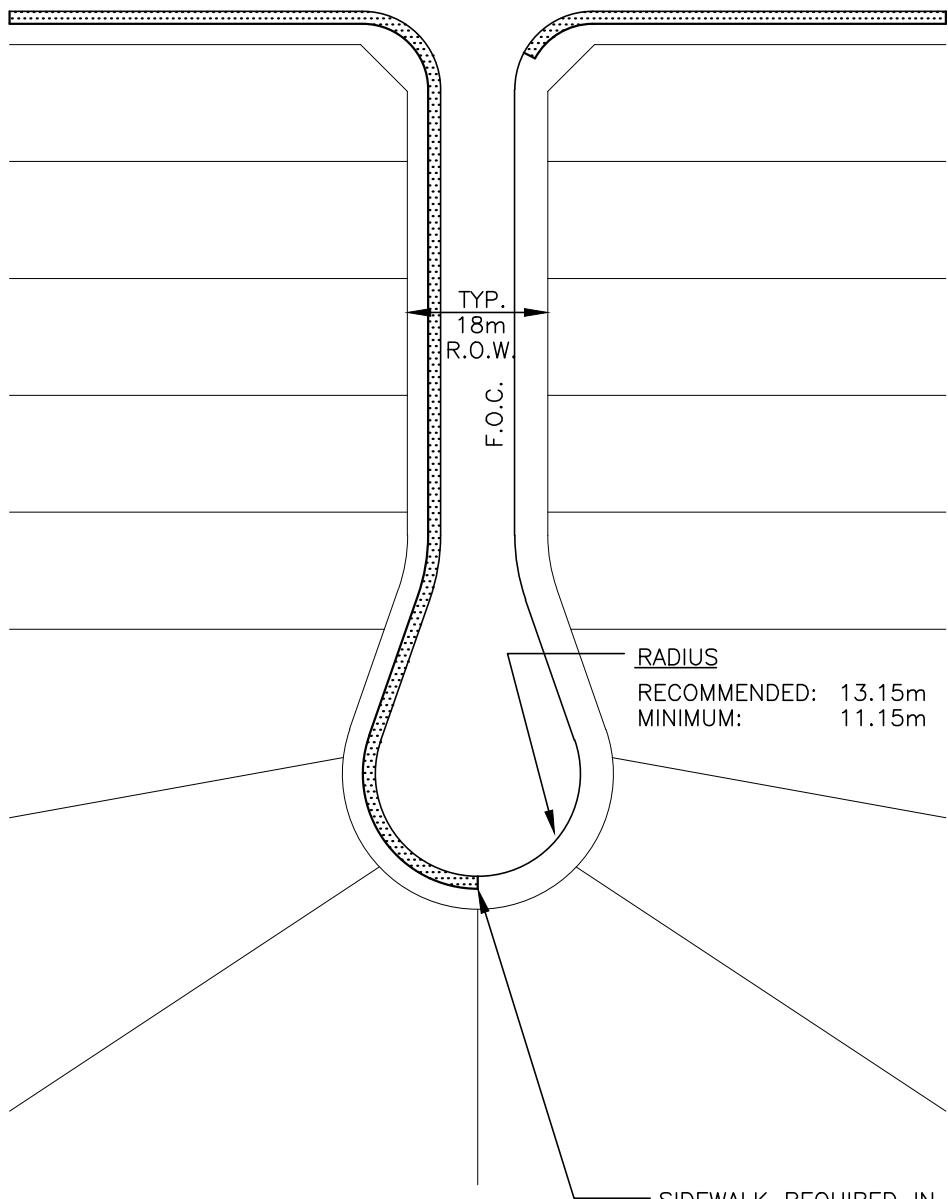

SIDEWALK REQUIRED IN CUL DE SACS OF MORE THAN 10 LOTS TO MINIMUM MID-RADIUS OR EXTENDED TO THE NEXT PROPERTY LINE.

XREFS

C:\DETAILS\SHEET2-TK

THE CITY OF
SPRUCE GROVE

PLANNING AND INFRASTRUCTURE

REVISIONS		
DATE	DETAILS	DRAWN
4/12	Drawing Number	RP

TYPICAL CUL DE SAC		
	DRAWN: T. CRAWFORD	DATE: MARCH 6, 2006
	CHECKED: J. MUSTARD	SCALE: NOT TO SCALE
	APPROVED: J. MUSTARD	DRAWING No.: TN-12

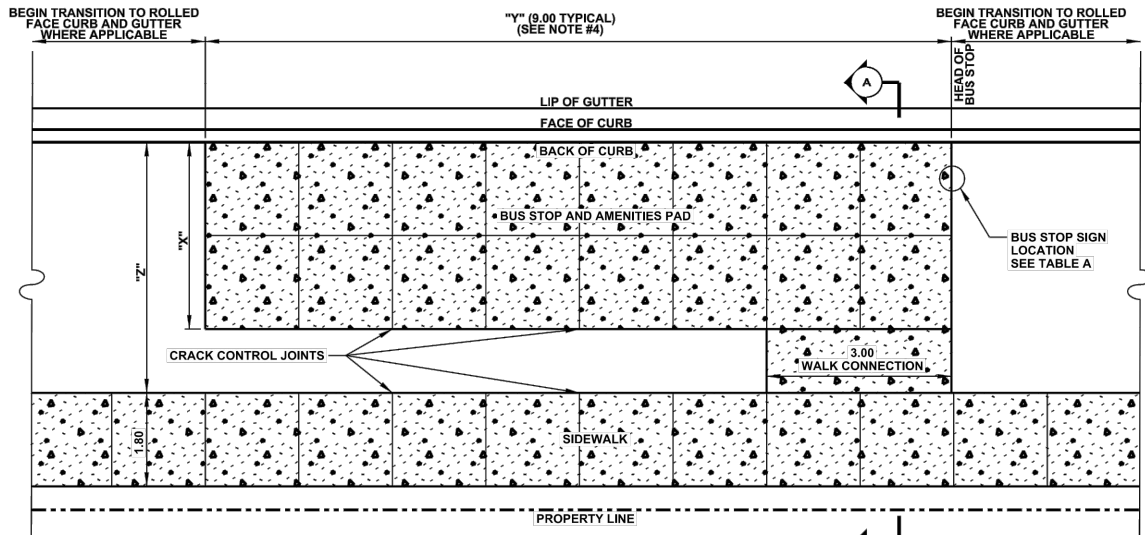

PLAN VIEW

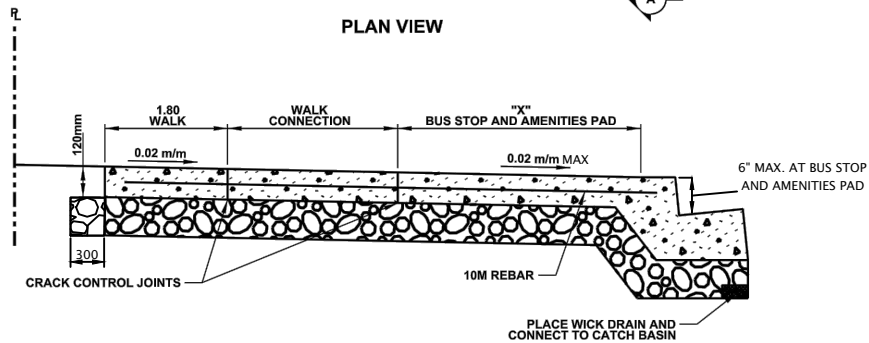

SECTION A-A

TABLE A
BUS STOP AND AMENITIES PAD SIZE

CONDITION	"Z" DISTANCE TO SIDEWALK	"X" REQUIRED PAD WIDTH	"Y" (SEE NOTE #4) REQUIRED PAD LENGTH	BUS STOP SIGN LOCATION
OVER CONSTRAINED	"Z" < 2.25	NOT PERMISSIBLE	NOT PERMISSIBLE	NOT PERMISSIBLE
CONSTRAINED	2.25 ≤ "Z" < 3.60	"X" = "Z"	12.00	3.00 BACK FROM HEAD OF PAD
NOT CONSTRAINED	3.60 ≤ "Z"	"X" = "Z" 4.10 (MAX.)	9.00	HEAD OF PAD

NOTES:

- PROVIDE BUS STOP AND AMENITIES PAD WITH WIDTH "X" AND LENGTH "Y" IN ACCORDANCE WITH THE DRAWING NOTES AND TABLE A (SEE ABOVE). PROVIDE APPROPRIATE CRACK CONTROL JOINTS THROUGHOUT.
- IF REQUIRED PAD WIDTH "X" IS LESS THAN 1.00m FROM SIDEWALK, POUR THE CONCRETE PAD TO SIDEWALK. OTHERWISE, PROVIDE 3.00m WIDE WALK CONNECTION AT HEAD OF THE PAD.
- STRAIGHT FACE CURB AND GUTTER REQUIRED AT BUS STOP.
- FOR REQUIRED LENGTH:
 - ADD 3.00 FOR MULTIPLE, FREQUENT ROUTES
 - ADD 5.00 FOR ARTICULATED BUS STOP
- IF REQUIRED, USE MAX. 4.0% LONGITUDINAL SIDEWALK GRADE BEFORE AND AFTER BUS STOP AND AMENITIES PAD TO ACHIEVE 6" MAX. CURB HEIGHT AT BUS STOP AND AMENITIES PAD WITH 2.0% LATITUDINAL GRADE.
- CEMENT STABILIZED SUBGRADE AND 150mm MINIMUM GRANULAR BASE UNDER ALL CONCRETE AND EXTENDING 300mm BEYOND EDGE OF CONCRETE")
- ALL DIMENSIONS IN METRES UNLESS OTHERWISE NOTED

XREFS

THE CITY OF
SPRUCE GROVE

PLANNING AND INFRASTRUCTURE

REVISIONS

DATE	DETAILS	DRAWN
09/20	STANDARDS UPDATE	WPS

TRANSIT STOP – SEP. WALK



DRAWN: R. PEDLAR	DATE: FEBRUARY 1, 2013
CHECKED: J. MUSTARD	SCALE: NOT TO SCALE
APPROVED: J. MUSTARD	DRAWING No.: TN-13

C:\DETAILS\SHEET2-TK

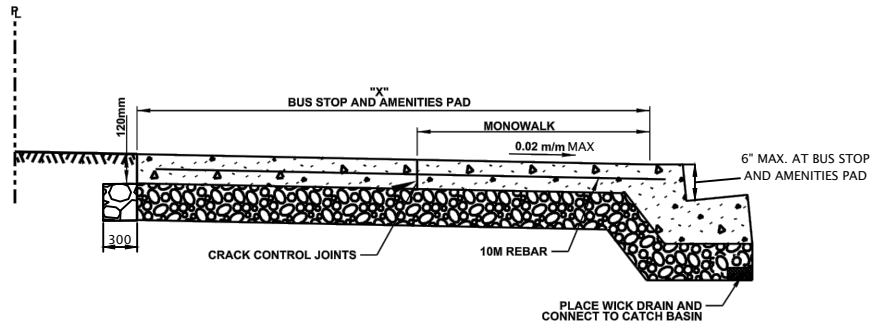
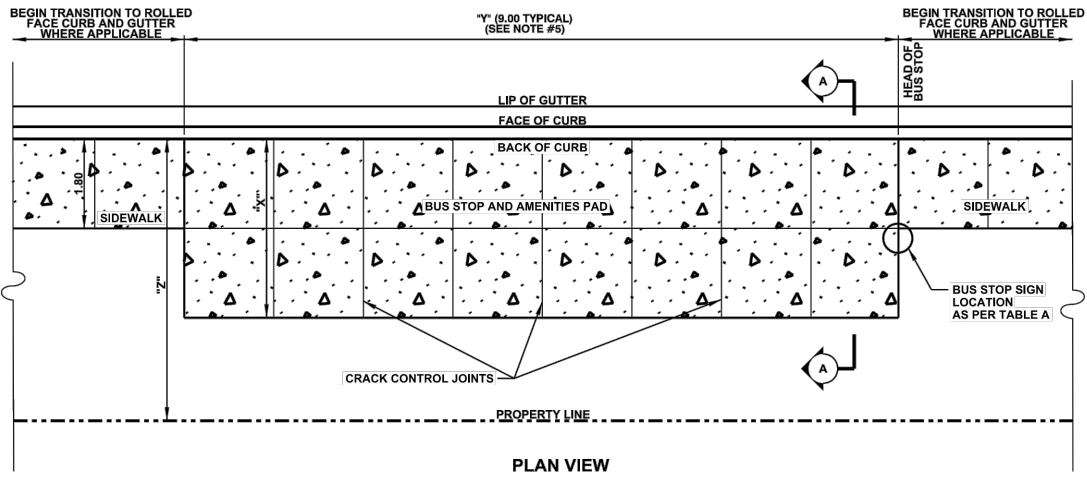

SECTION A-A

TABLE A BUS STOP AND AMENITIES PAD SIZE				
CONDITION	"Z" DISTANCE TO PROPERTY LINE	"X" REQUIRED PAD WIDTH	(SEE NOTE #5) "Y" REQUIRED PAD LENGTH	BUS STOP SIGN LOCATION BEHIND SIDEWALK
OVER CONSTRAINED	"Z" < 2.80	2.10	9.00	HEAD OF PAD
CONSTRAINED	2.80 ≤ "Z" < 3.90	"Z" - 0.30 [3.00 (MAX.)]	12.00	3.00 BACK FROM HEAD OF PAD
NOT CONSTRAINED	"Z" > 3.90	"Z" - 0.30 [4.10 (MAX.)]	9.00	HEAD OF PAD

NOTES:

1. PROVIDE BUS STOP AND AMENITIES PAD WITH WIDTH "X" AND LENGTH "Y" IN ACCORDANCE WITH THE DRAWING NOTES AND TABLE A (SEE ABOVE). PROVIDE APPROPRIATE CRACK CONTROL JOINTS THROUGHOUT.
2. MAINTAIN 0.30m (MIN.) CLEARANCE BETWEEN PROPERTY LINE AND AMENITIES PAD.
3. STRAIGHT FACE CURB AND GUTTER REQUIRED AT BUS STOP.
4. BUS STOP AND AMENITIES PAD TO BE POURED MONOLITHICALLY WITH CURB AND GUTTER.
5. FOR REQUIRED LENGTH:
- ADD 3.00 FOR MULTIPLE, FREQUENT ROUTES
- ADD 5.00 FOR ARTICULATED BUS STOP
6. CEMENT STABILIZED SUBGRADE AND 150mm MINIMUM GRANULAR BASE UNDER ALL CONCRETE AND EXTENDING 300mm BEYOND EDGE OF CONCRETE)
7. ALL DIMENSIONS IN METRES UNLESS OTHERWISE NOTED

XREFS

THE CITY OF
SPRUCE GROVE

PLANNING AND INFRASTRUCTURE

REVISIONS		
DATE	DETAILS	DRAWN
09/20	STANDARDS UPDATE	WPS

TRANSIT STOP – MONO WALK		
	DRAWN: R. PEDLAR	DATE: FEBRUARY 1, 2013
	CHECKED: J. MUSTARD	SCALE: NOT TO SCALE
	APPROVED: J. MUSTARD	DRAWING No.: TN-14

C:\DETAILS\SHEET2-TK

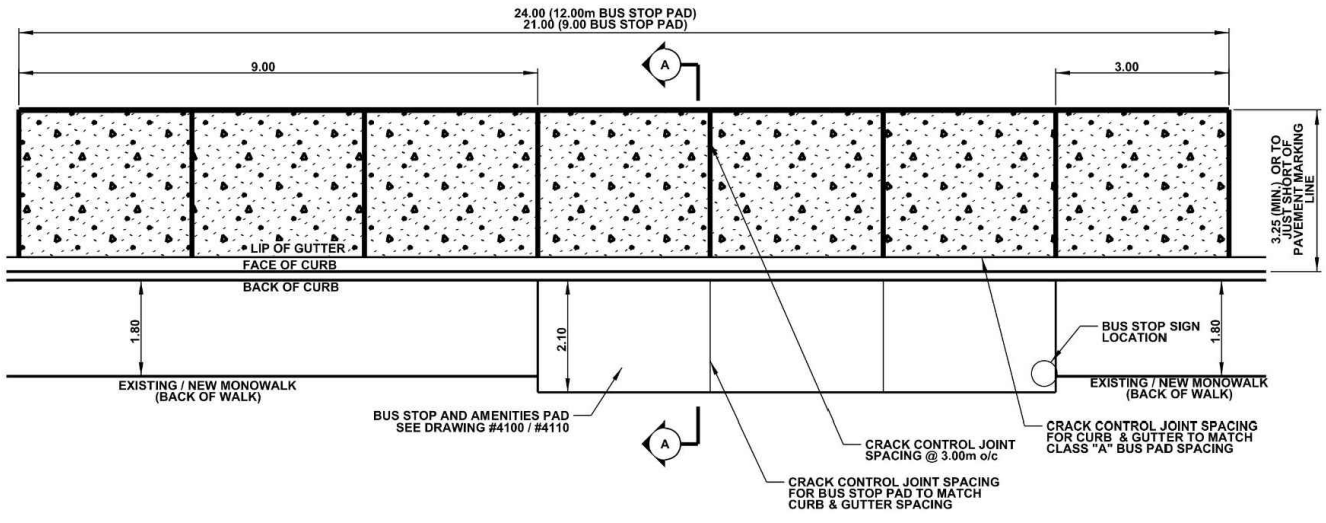

PLAN VIEW

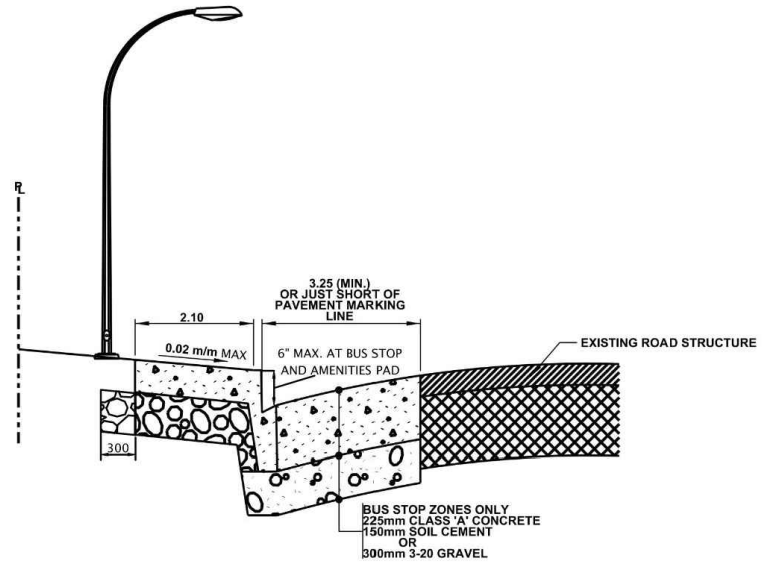

SECTION A-A

- NOTES: 1. STRAIGHT FACE CURB AND GUTTER REQUIRED AT BUS STOP.
 2. CEMENT STABILIZED SUBGRADE AND 150mm MINIMUM GRANULAR BASE UNDER ALL CONCRETE AND EXTENDING 300mm BEYOND EDGE OF CONCRETE
 3. ALL DIMENSIONS IN METERS UNLESS OTHERWISE NOTED.

THE CITY OF SPRUCE GROVE **PLANNING AND INFRASTRUCTURE**

REVISIONS			DRIVE WAY / TYPICAL LANE TIE-IN		
DATE	DETAILS	DRAWN			
4/12	Rev. CL depth	RP		DRAWN: T. CRAWFORD	DATE: MARCH 6, 2006
3/13	GRANULAR BASE	SW		CHECKED: J. MUSTARD	SCALE: NOT TO SCALE
9/12	Standards Update	WPS		APPROVED: J. MUSTARD	DRAWING No.: TN-15

XREFS

C:\DETAILS\SHEET2-TK

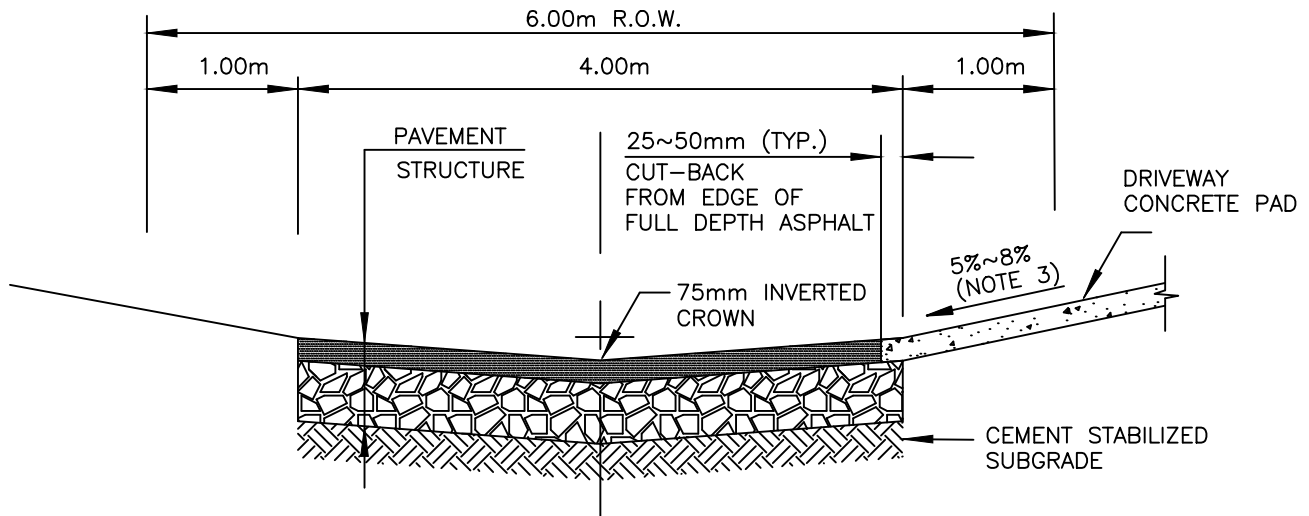

CROSS SECTION

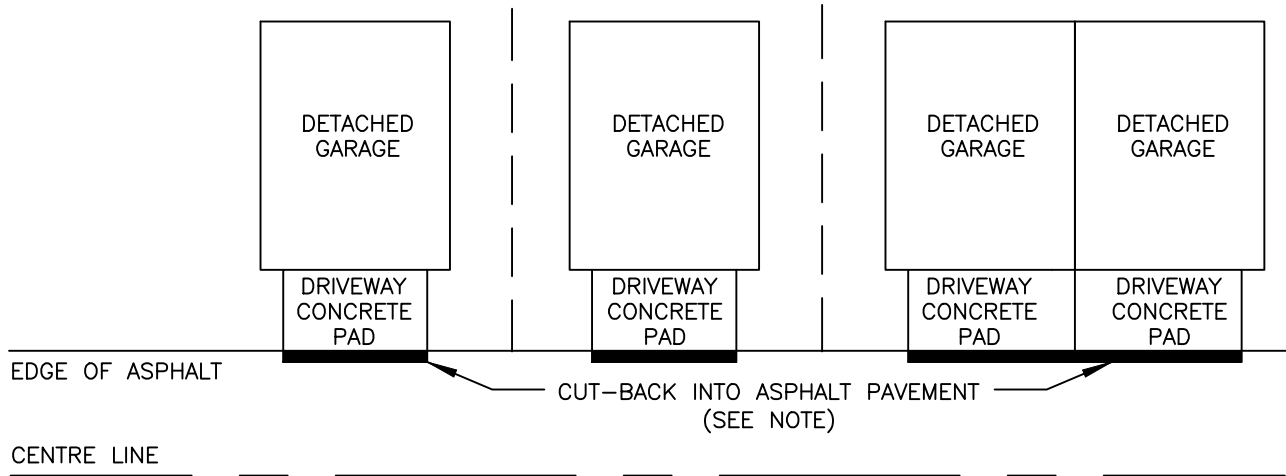

PLAN VIEW

- NOTES: 1. WHERE THE DRIVEWAY CONNECTS TO THE LANE, SAW-CUT 1"~2" (25mm TO 50mm) INTO EDGE OF FULL DEPTH ASPHALT AND CREATE SMOOTH AND STRAIGHT EDGE. TIE CONCRETE FLUSH WITH PROPER EXPANSION JOINT FOAM SEPARATING THE TWO.
2. DRIVEWAYS ADJACENT TO LANES MUST BE FRAMED AND POURED FLUSH IN ELEVATION TO WITHIN ¼" (6mm) OF THE EDGE OF PAVEMENT OF THE LANE. ALL DRIVEWAYS EXCEEDING ½" (12mm) DIFFERENCE IN ELEVATION WILL BE REQUIRED TO BE REMOVED AND REPLACED AS PER MUNICIPAL DEVELOPMENT STANDARDS AND APPROVED DEVELOPMENT AND BUILDING PERMITS.
3. A GRADE OF 5% TO 8% FOR DRIVEWAY AWAY FROM GARAGE IS REQUIRED TO CONFORM TO THE APPROVED LOT GRADING DESIGN.

THE CITY OF
SPRUCE GROVE

PLANNING AND INFRASTRUCTURE

REVISIONS

DATE	DETAILS	DRAWN

DRIVE WAY / TYPICAL LANE TIE-IN



DRAWN: S. WU	DATE: SEPTEMBER 04, 2015
CHECKED: J. MUSTARD	SCALE: NOT TO SCALE
APPROVED: J. MUSTARD	DRAWING No.: TN-16

XREFS

C:\DETAILS\SHEET2-TK

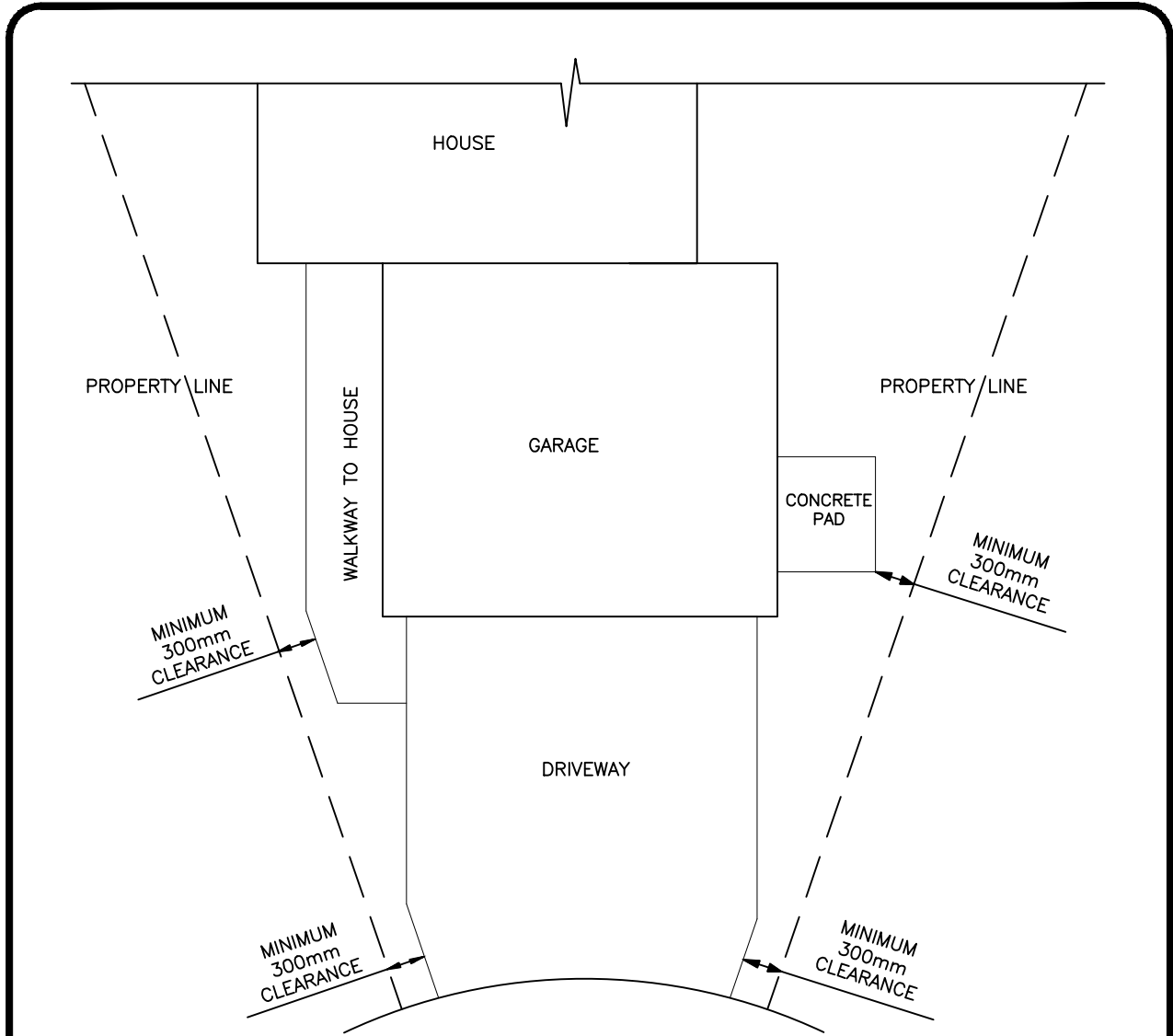

PLAN VIEW

- NOTES: 1. FOR ANY CONCRETE PADS, I.E. DRIVEWAYS, WALKWAYS TO HOUSES, STEPS, ETC., A MINIMUM OF 300mm (1 ft.) CLEARANCE AWAY FROM SIDE PROPERTY LINES OR ANY MUNICIPAL FIXTURES IS REQUIRED.
2. IN CULS-DE-SAC, THE DRIVEWAYS OR WALKWAYS TO HOUSES NEED TO BE FORMED/SAW-CUT WITH AN ANGLE TO MEET THE MINIMUM CLEARANCE OF 300mm (1 ft.) AWAY FROM SIDE PROPERTY LINES.

THE CITY OF SPRUCE GROVE **PLANNING AND INFRASTRUCTURE**

REVISIONS		
DATE	DETAILS	DRAWN

CLEARANCE FOR DRIVEWAY/CONCRETE

	DRAWN: S. WU	DATE: SEPTEMBER 04, 2015
	CHECKED: J. MUSTARD	SCALE: NOT TO SCALE
	APPROVED: J. MUSTARD	DRAWING No.: TN-17

XREFS

C:\DETAILS\SHETZ-TK

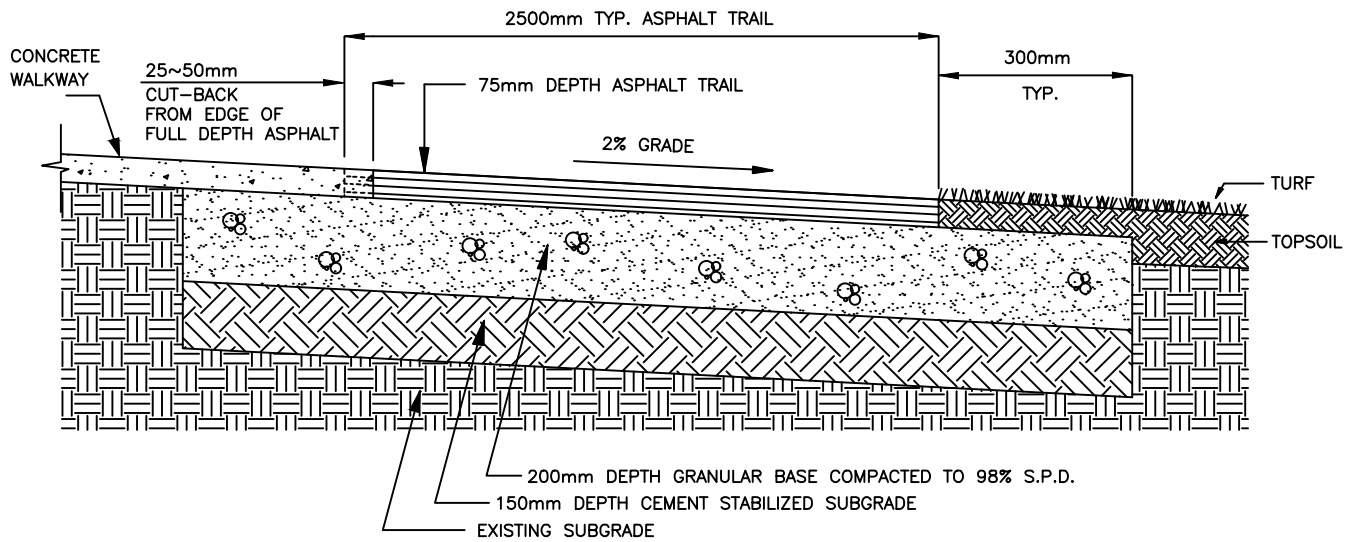

CROSS SECTION

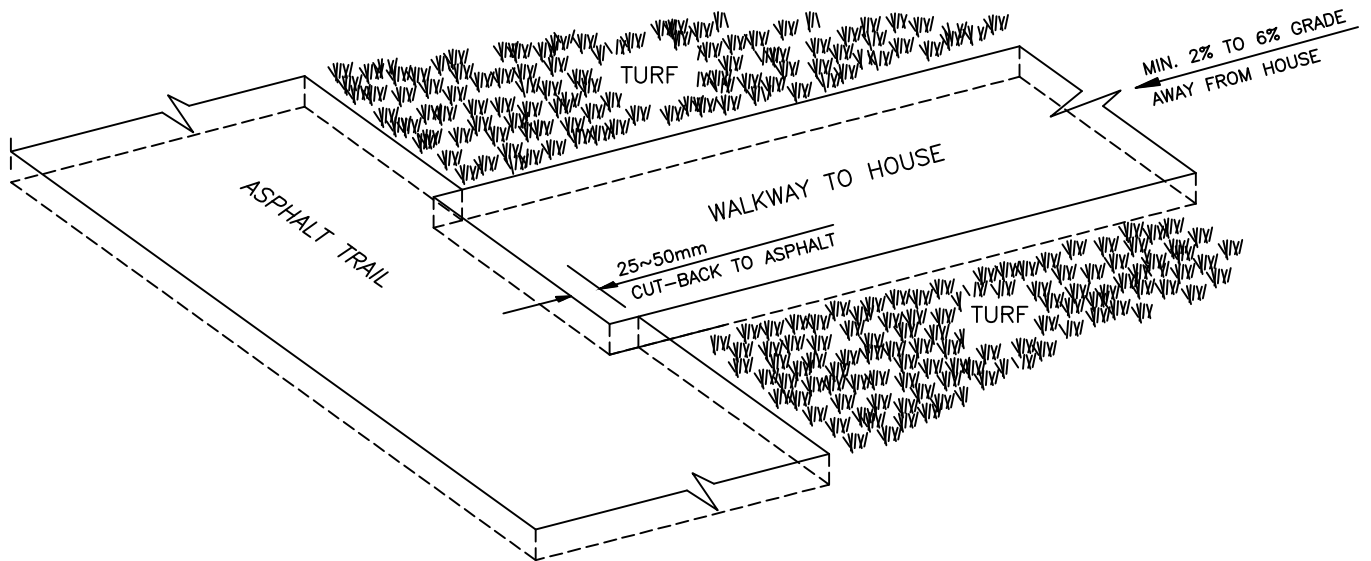

3-DIMENSIONAL VIEW

NOTES:

1. IT IS THE BUILDER'S/CONTRACTOR'S RESPONSIBILITY TO REHABILITATE ALL DISTURBED AREAS ALONG TRAIL EDGE WITH TOPSOIL AND SOD.
2. WHERE THE WALKWAY CONNECTS TO THE TRAIL, SAW-CUT 1"~2" (25mm~50mm) INTO EDGE OF FULL DEPTH ASPHALT AND CREATE SMOOTH AND STRAIGHT EDGE. TIE CONCRETE FLUSH WITH PROPER EXPANSION JOINT FOAM SEPARATING THE TWO.
3. WALKWAYS ADJACENT TO LANES MUST BE FRAMED AND POURED FLUSH IN ELEVATION TO WITHIN 1/4" (6mm) OF THE EDGE OF PAVEMENT OF THE LANE. ALL WALKWAYS EXCEEDING 1/2" (12mm) DIFFERENCE IN ELEVATION WILL BE REQUIRED TO BE REMOVED AND REPLACED AS PER THE MUNICIPAL DEVELOPMENT STANDARDS AND APPROVED DEVELOPMENT AND BUILDING PERMITS.

THE CITY OF
SPRUCE GROVE

PLANNING AND INFRASTRUCTURE

XREFS

C:\DETAILS\SHEET2-TK

REVISIONS		
DATE	DETAILS	DRAWN
2/22	Standards Update	

RESIDENTIAL CONCRETE WALKWAY / TRAIL TIE-IN		
	DRAWN: S. WU	DATE: FEBRUARY 10, 2022
	CHECKED: J. MUSTARD	SCALE: NOT TO SCALE
	APPROVED: J. MUSTARD	DRAWING No.: TN-18

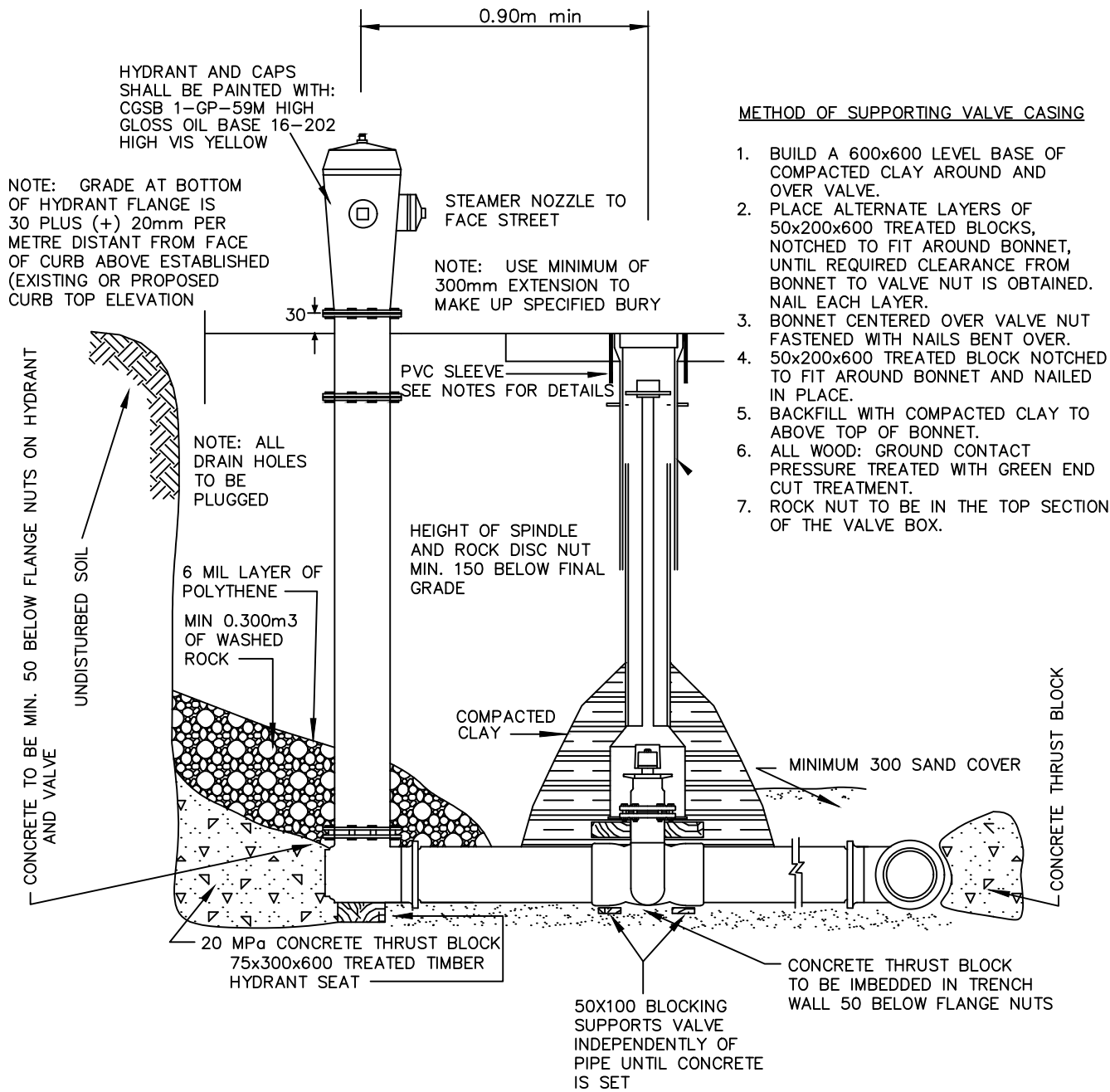

METHOD OF SUPPORTING VALVE CASING

1. BUILD A 600x600 LEVEL BASE OF COMPACTED CLAY AROUND AND OVER VALVE.
2. PLACE ALTERNATE LAYERS OF 50x200x600 TREATED BLOCKS, NOTCHED TO FIT AROUND BONNET, UNTIL REQUIRED CLEARANCE FROM BONNET TO VALVE NUT IS OBTAINED. NAIL EACH LAYER.
3. BONNET CENTERED OVER VALVE NUT FASTENED WITH NAILS BENT OVER.
4. 50x200x600 TREATED BLOCK NOTCHED TO FIT AROUND BONNET AND NAILED IN PLACE.
5. BACKFILL WITH COMPACTED CLAY TO ABOVE TOP OF BONNET.
6. ALL WOOD: GROUND CONTACT PRESSURE TREATED WITH GREEN END CUT TREATMENT.
7. ROCK NUT TO BE IN THE TOP SECTION OF THE VALVE BOX.

NOTES:

1. HYDRANTS ARE TO BE McAVITY OR CANADA VALVE.
2. HYDRANTS TO BE EQUIPPED WITH A 125mm STORZ INTERNAL LUG QUICK CONNECTION NOZZLE OR EQUIVALENT
3. HYDRANT DRAIN HOLES TO BE PLUGGED.
4. ALL BOLTS TO BE 316 STAINLESS STEEL, WITH BELOW GRADE BOLTS WRAPPED WITH DENSO MASTIC AND DENSO TAPE
5. PVC SLEEVE TO BE USED WHEN VALVE IS INCORPORATED WITHIN CONCRETE.
6. CATHODIC PROTECTION REQUIRED. REFER TO DRAWINGS WR-07 & WR-08 FOR EXTERNAL ANODES.
7. INTERNAL ANODE TO BE INSTALLED IN HYDRANT BARREL.
8. ALL DIMENSIONS ARE IN MILLIMETERS UNLESS OTHERWISE INDICATED.

THE CITY OF
SPRUCE GROVE

PLANNING AND INFRASTRUCTURE

REVISIONS

DATE	DETAILS	DRAWN
4/15	CHANGES TO NOTES	RP
4/19	Standards Update	RP
9/20	Standards Update	WPS
2/22	Standards Update	

HYDRANT AND VALVE



DRAWN: T. CRAWFORD	DATE: FEBRUARY 10, 2022
CHECKED: J. MUSTARD	SCALE: NOT TO SCALE
APPROVED: J. MUSTARD	DRAWING No.: WR-01

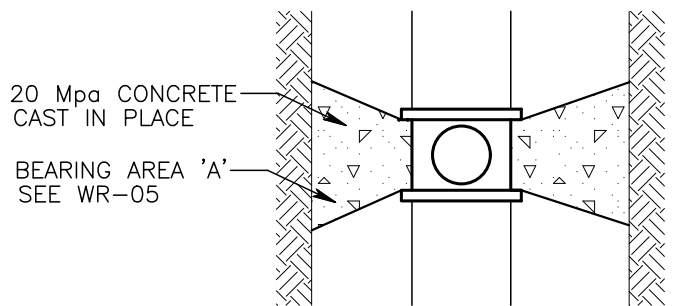
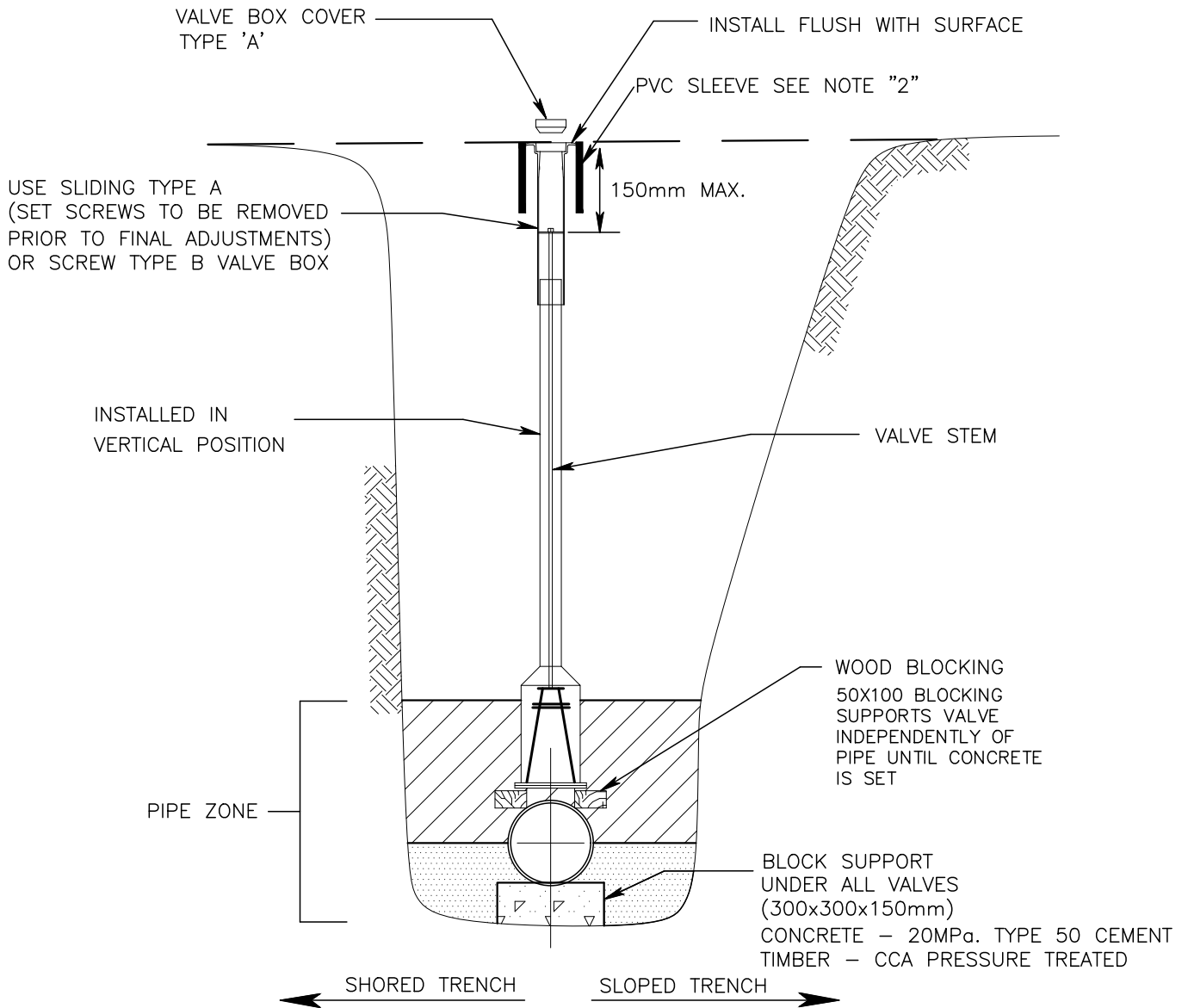

THRUST BLOCK DETAIL

NOTES:

1. ALL BOLTS TO BE STAINLESS STEEL WRAPPED WITH DENSO MASTIC AND DENSO TAPE.
2. PVC SLEEVE TO BE USED WHEN VALVE IS INCORPORATED WITHIN CONCRETE.
3. CATHODIC PROTECTION REQUIRED. REFER TO DRAWINGS WR-07 & WR-08.

THE CITY OF
SPRUCE GROVE

PLANNING AND INFRASTRUCTURE

REVISIONS

DATE	DETAILS	DRAWN
04/12	WOOD BLOCKING DETAIL	RP
02/21	VALVE BOX NOTE	AS

VALVE INSTALLATION (300mm)



DRAWN: T. CRAWFORD	DATE: MARCH 6, 2006
CHECKED: J. MUSTARD	SCALE: NOT TO SCALE
APPROVED: J. MUSTARD	DRAWING No.: WR-02

XREFS

C:\DETAILS\ SHEET2-TK

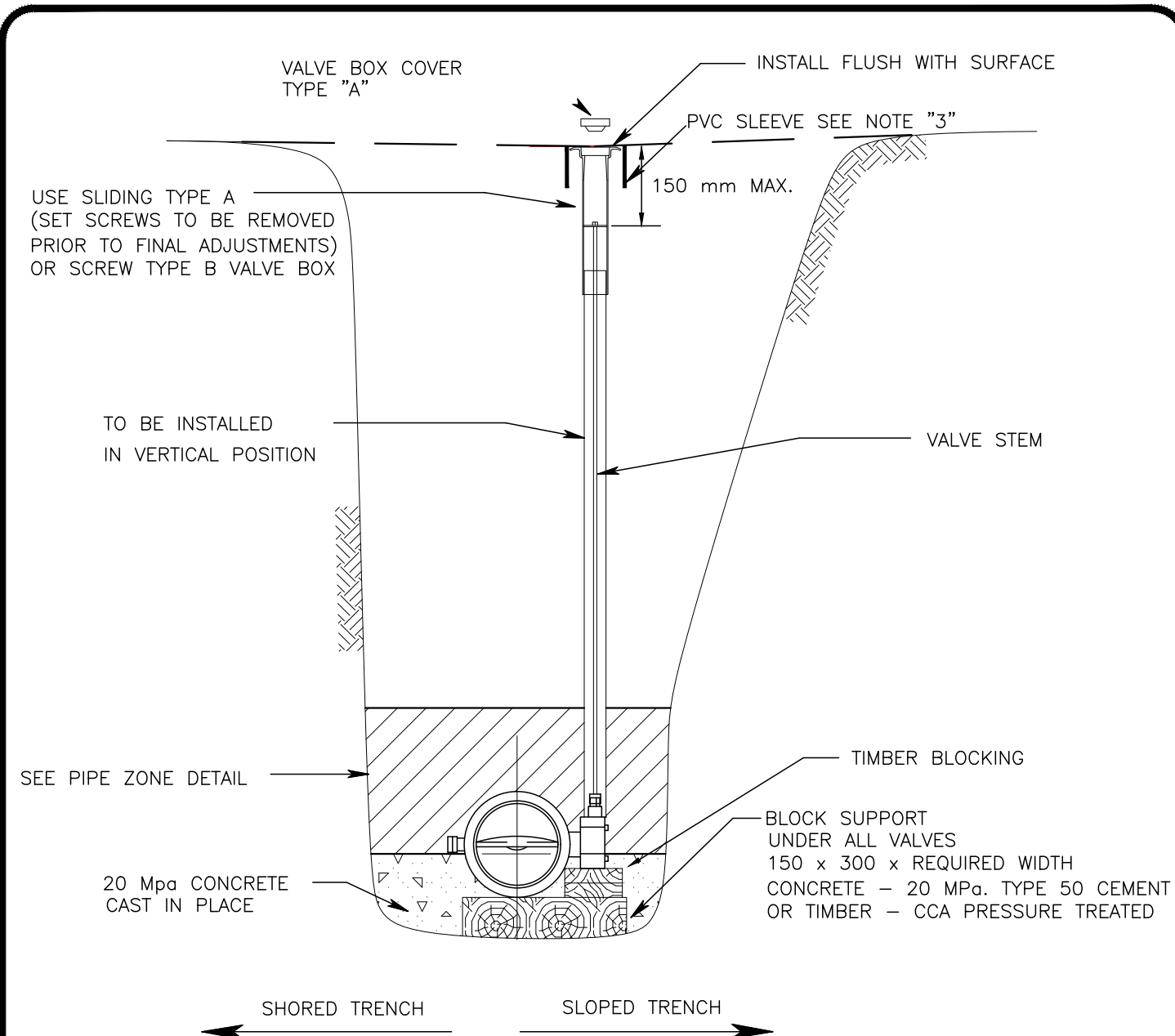

NOTES:

1. PAINT TOP OF INTERIOR BOX BRIGHT RED AND STAMP CAP 'BV'
2. ALL BOLTS TO BE STAINLESS STEEL WRAPPED WITH DENSO MASTIC AND TAPE.
3. PVC SLEEVE TO BE USED WHEN VALVE IS INCORPORATED WITHIN CONCRETE.
4. CATHODIC PROTECTION REQUIRED. REFER TO DRAWINGS WR-07 & WR-08.

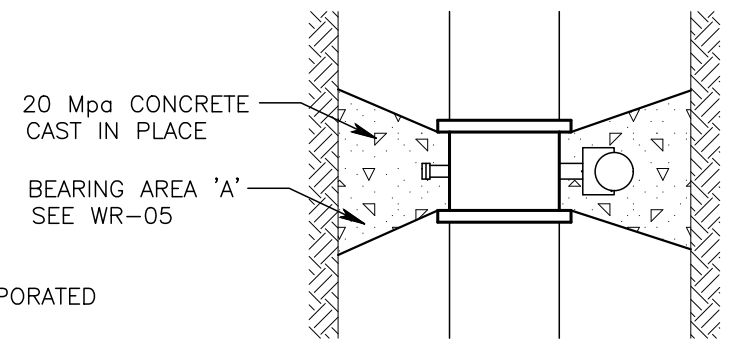

XREFS

C:\DETAILS\ SHEET2-TK

**THE CITY OF
SPRUCE GROVE**

PLANNING AND INFRASTRUCTURE

REVISIONS		
DATE	DETAILS	DRAWN
02/21	VALVE BOX NOTE	AS

BUTTERFLY VALVE (<300mm)

DRAWN: T. CRAWFORD

CHECKED: J. MUSTARD

APPROVED: J. MUSTARD

DATE: MARCH 6, 2006

SCALE: NOT TO SCALE

DRAWING No.: WR-03



NOTES:

- 1. ALL BOLTS TO BE STAINLESS STEEL WRAPPED WITH DENSO MASTIC AND DENSO TAPE.
- 2. CATHODIC PROTECTION REQUIRED. REFER TO DRAWINGS WR-07 & WR-08.
- 3. VALVE CASING AND OPERATING ROD FOR A HOT TAP VALVE SHOULD NOT BE INSTALLED.
- 4. THE LOCATION OF THE HOT TAP VALVE SHALL BE IDENTIFIED ON THE AS-BUILT DRAWINGS.

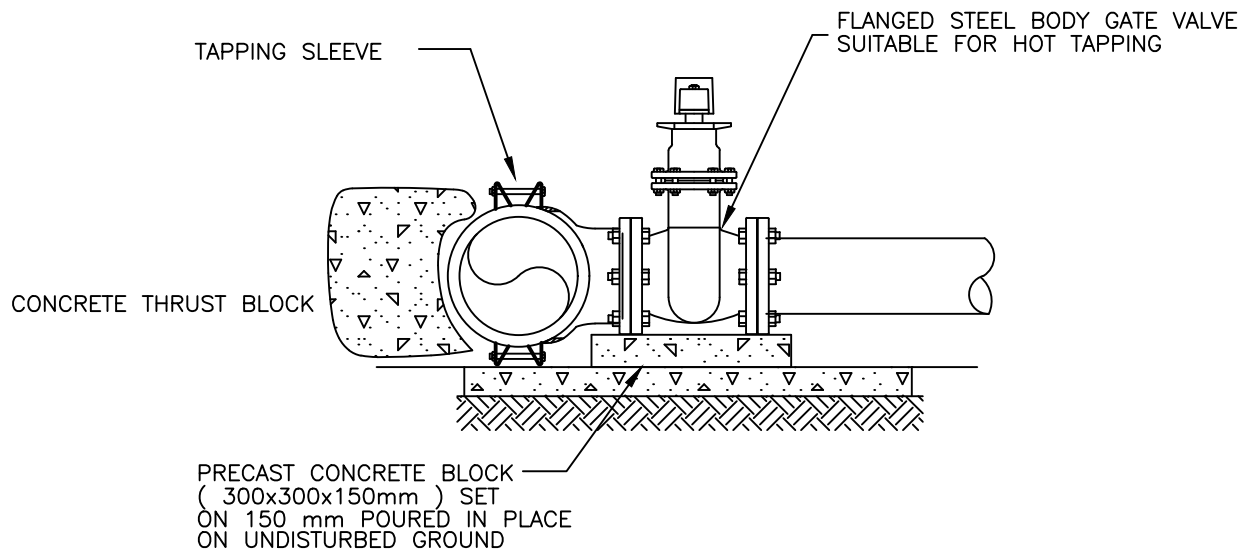

XREFS

C:\DETAILS\SHEET2-TK

THE CITY OF
SPRUCE GROVE

PLANNING AND INFRASTRUCTURE

REVISIONS

DATE	DETAILS	DRAWN
02/14	REMOVED VALVE CASING/ROD	RP
02/14	ADDITIONAL NOTES	RP
04/19	Standards Update	WPS

HOT TAP



DRAWN: T. CRAWFORD	DATE: MARCH 6, 2006
CHECKED: J. MUSTARD	SCALE: NOT TO SCALE
APPROVED: J. MUSTARD	DRAWING No.: WR-04

BEND DEFLECTION

90°	1.4A
45°	0.7A
22 1/2°	0.35A
11 1/4°	0.18A

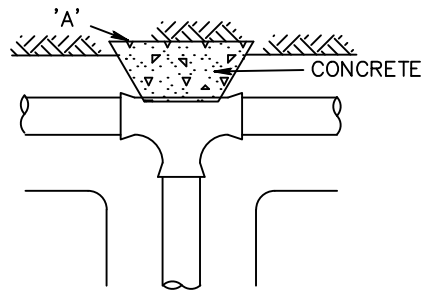
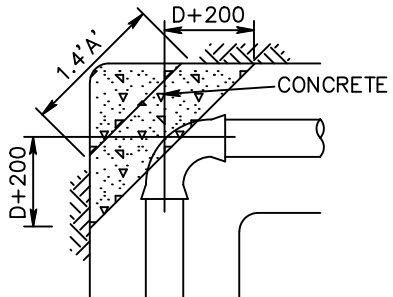

19mm PRESSURE TREATED PLYWOOD SEPARATOR

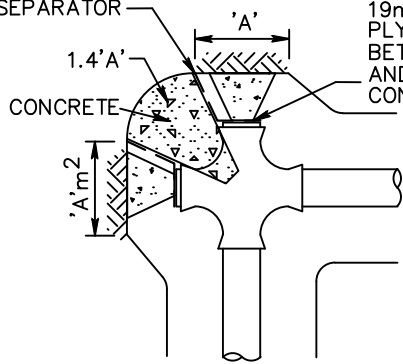

19mm PRESSURE TREATED PLYWOOD SEPARATOR BETWEEN THRUST BLOCK AND PLUG; ADJACENT CONCRETE, TYP.

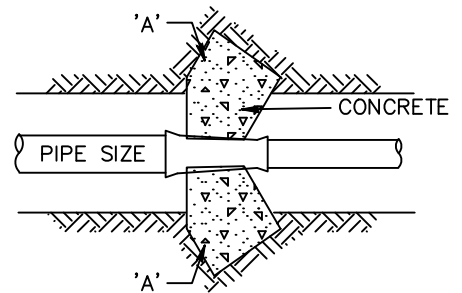
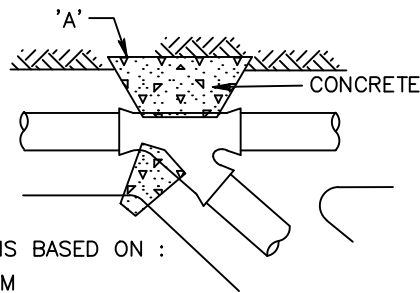
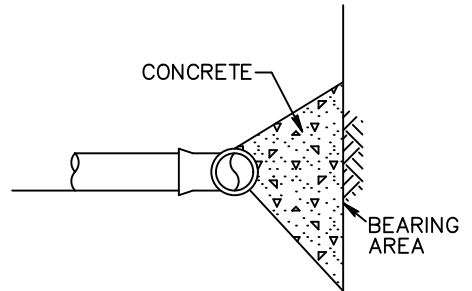
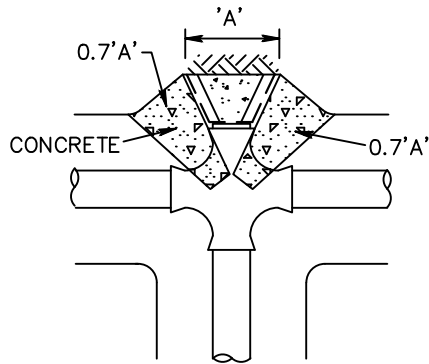
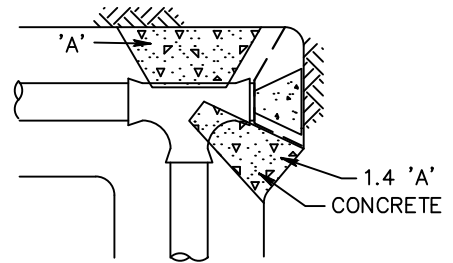

THRUST BLOCK DESIGN IS BASED ON :

- 1050kPa MAX. SYSTEM PRESSURE OR 700kPa OPERATING PRESSURE PLUS A SURGE ALLOWANCE OF 345kPa (2fps SURGE ALLOWANCE AT 25psi/fps)
- THRUST BLOCK DESIGN ASSUMES A MIN. VERTICAL SOIL BEARING OF 100kPa
- THRUST BLOCK BEARING AREA BASED ON P.V.C. PIPE (AWWA C900 AND C905 DR18)
- CONCRETE 20MPa TYPE HS CEMENT.
- ALL WOOD: GROUND CONTRACT PRESSURE TREATED W/ GREEN END CUT TREATMENT

TABLE - FOR CALCULATION OF BASIC THRUST BLOCK BEARING AREA 'A' (IN SQUARE METRES)

PIPE SIZE	150	200	250	300	350	400	450
'A'	0.40	0.68	1.06	1.54	2.08	2.72	3.44

XREFS

C:\DETAILS\SHEET2-TK

THE CITY OF SPRUCE GROVE

PLANNING AND INFRASTRUCTURE

REVISIONS

DATE	DETAILS	DRAWN
04/19	Standards Update	WPS

THRUST BLOCK



DRAWN: T. CRAWFORD	DATE: MARCH 6, 2006
CHECKED: J. MUSTARD	SCALE: NOT TO SCALE
APPROVED: J. MUSTARD	DRAWING No.: WR-05

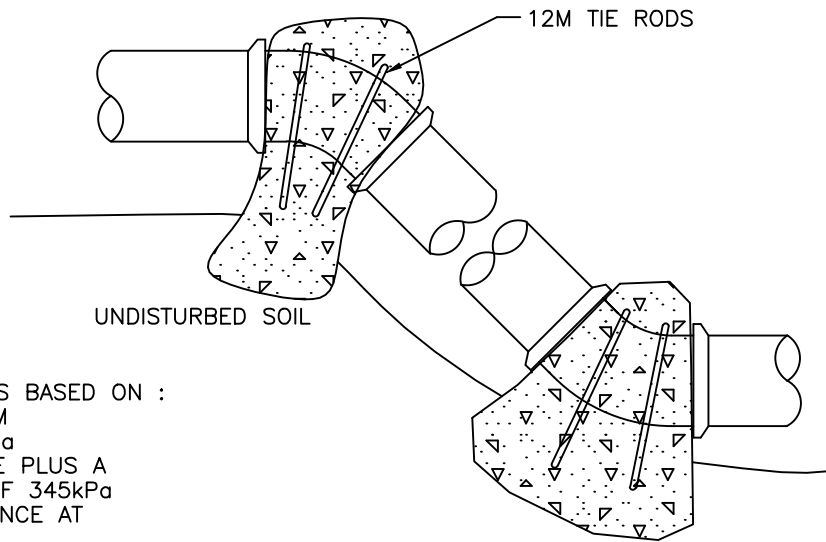

VERTICAL BEND

THRUST BLOCK DESIGN IS BASED ON :

1. 1050kPa MAX. SYSTEM PRESSURE OR 700kPa OPERATING PRESSURE PLUS A SURGE ALLOWANCE OF 345kPa (2fps SURGE ALLOWANCE AT 25psi/fps)
2. THRUST BLOCK DESIGN ASSUMES A MIN. VERTICAL SOIL BEARING OF 100kPa
3. THRUST BLOCK BEARING AREA BASED ON P.V.C. PIPE (AWWA C900 AND C905 DR18)
4. CONCRETE 20MPa TYPE HS CEMENT.
5. IF THE SOIL CONDITIONS PROVIDE LESS THAN 100kPa BEARING STRENGTH, DETAILED THRUST BLOCK DESIGN MUST BE COMPLETED AND SUBMITTED FOR REVIEW.

UPWARD THRUST (GRAVITY)

TABLE – FOR CALCULATION OF BASIC THRUST BLOCK BEARING AREA (IN SQUARE METRES)
CONCRETE UNIT WEIGHT 2400Kg/cu.m

BEND \ PIPE SIZE *	150	200	250	300	350	400	450
11.25°	0.16	0.28	0.45	0.64	0.87	1.14	1.44
22.50°	0.32	0.57	0.88	1.27	1.73	2.26	2.82
30°	0.42	0.75	1.17	1.69	2.30	3.00	3.80
45°	0.62	1.11	1.73	2.50	3.40	4.44	5.62

DOWNWARD THRUST

TABLE – FOR CALCULATION OF BASIC THRUST BLOCK BEARING AREA (IN SQUARE METRES)
CONCRETE UNIT WEIGHT 2400Kg/cu.m

BEND \ PIPE SIZE *	150	200	250	300	350	400	450
11.25°	0.04	0.07	0.11	0.15	0.21	0.27	0.34
22.50°	0.08	0.13	0.21	0.30	0.41	0.53	0.67
30°	0.10	0.18	0.28	0.40	0.54	0.71	0.89
45°	0.15	0.26	0.41	0.59	0.80	1.05	1.32

* NOMINAL PIPE SIZES ARE IN MILLIMETERS

XREFS

C:\DETAILS\SHEET2-TK

THE CITY OF
SPRUCE GROVE

PLANNING AND INFRASTRUCTURE

REVISIONS

DATE	DETAILS	DRAWN
04/19	Standards Update	WPS
09/20	STANDARDS UPDATE	WPS

VERTICAL THRUST BLOCK



DRAWN: T. CRAWFORD	DATE: MARCH 6, 2006
CHECKED: J. MUSTARD	SCALE: NOT TO SCALE
APPROVED: J. MUSTARD	DRAWING No.: WR-06

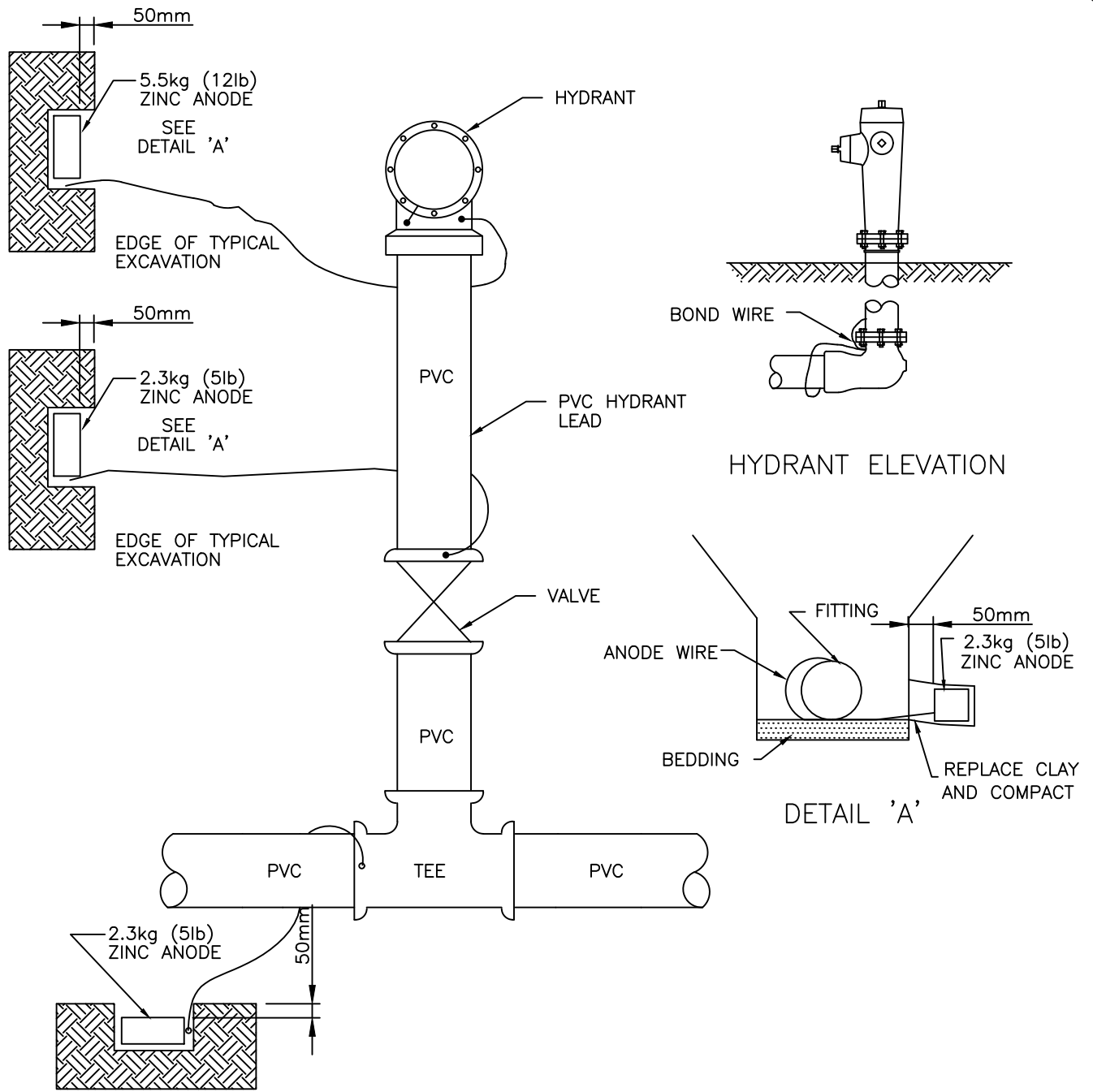

NOTES:

1. MINIMUM DISTANCE FROM ANODE TO PIPE, FITTING, VALVE, OR HYDRANT IS 150mm.
2. INSTALL ANODE AT APPROX. PIPE DEPTH IN NATIVE SOIL.
3. ZINC ANODES TO BE EMBEDDED INTO TRENCH WALL TO PROVIDE FOR A MINIMUM OF 50mm OF NATIVE CLAY COMPLETELY SURROUNDING THE ANODE.
4. ANODES TO BE AT LEAST 300mm CLEAR OF THRUST BLOCK.
5. ACTIVATE ANODES BY WATER PRE-SOAKING BEFORE INSTALLATION.

THE CITY OF
SPRUCE GROVE

PLANNING AND INFRASTRUCTURE

REVISIONS

DATE	DETAILS	DRAWN
02/14	DRAWING NUMBER	RP
04/19	Standards Update	WPS

HYDRANT ANODE



DRAWN: T. CRAWFORD	DATE: MARCH 6, 2006
CHECKED: J. MUSTARD	SCALE: NOT TO SCALE
APPROVED: J. MUSTARD	DRAWING No.: WR-07

XREFS

C:\DETAILS\SHEET2-TK

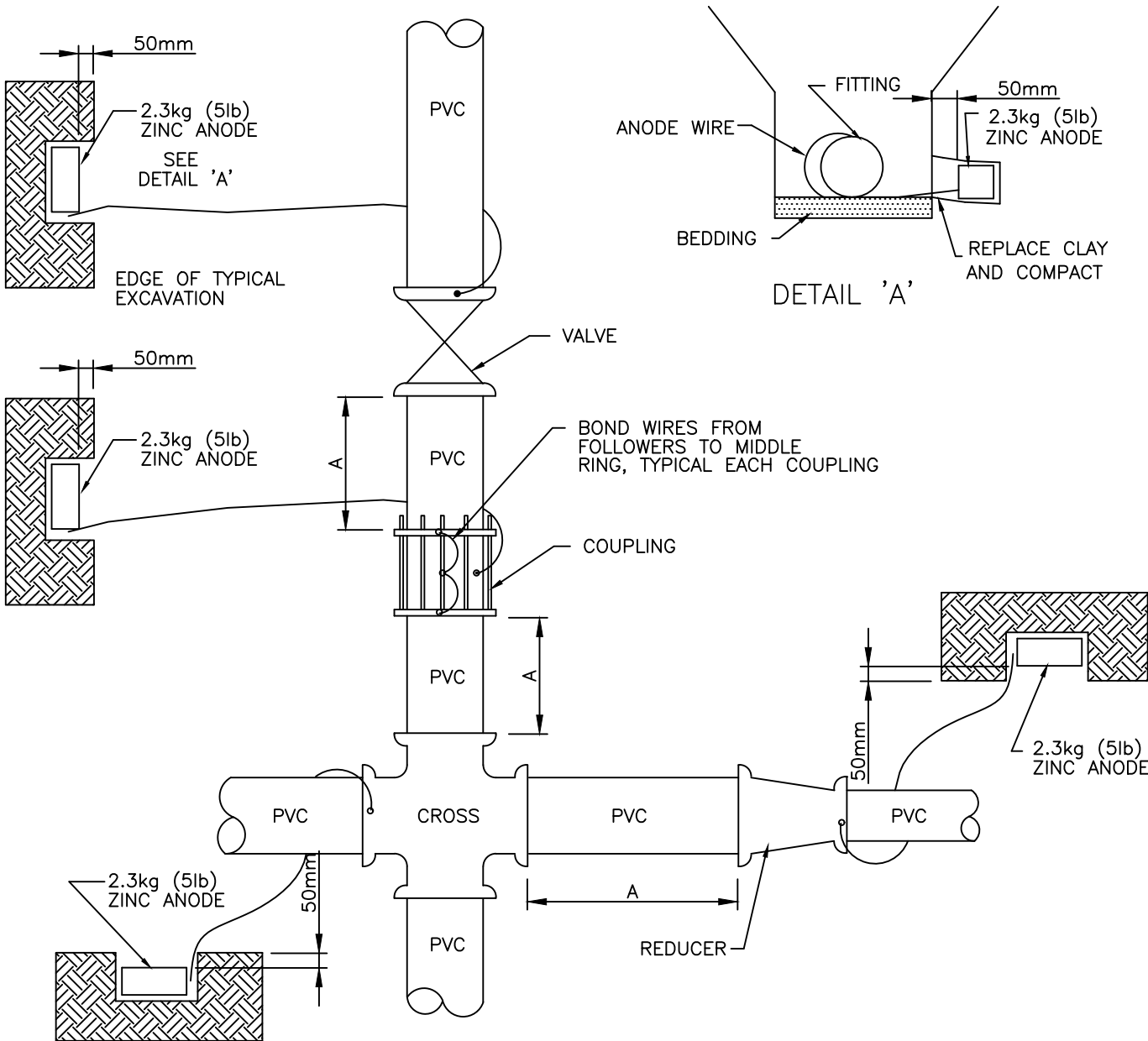

NOTES:

1. MINIMUM DISTANCE FROM ANODE TO PIPE, FITTING, VALVE, OR HYDRANT IS 150mm.
2. INSTALL ANODE AT APPROX. PIPE DEPTH IN NATIVE SOIL.
3. BOND WIRES MAY BE USED TO PROTECT UP TO TWO FITTINGS WITH ONE ANODE WHEN DIMENSION 'A' DOES NOT EXCEED ONE (1) METER.
4. ALL ZINC ANODES ON FITTINGS AND VALVES ARE 2.3kg (5lb).
5. ZINC ANODES TO BE EMBEDDED INTO TRENCH WALL TO PROVIDE FOR A MINIMUM OF 50mm OF NATIVE CLAY COMPLETELY SURROUNDING THE ANODE.
6. ANODES TO BE AT LEAST 300mm CLEAR OF THRUST BLOCK.
7. ACTIVATE ANODES BY WATER PRE-SOAKING BEFORE INSTALLATION.

XREFS

C:\DETAILS\SHEET2-TK

THE CITY OF
SPRUCE GROVE

PLANNING AND INFRASTRUCTURE

REVISIONS

DATE	DETAILS	DRAWN
02/14	DRAWING NUMBER	RP
04/19	Standards Update	WPS

VALVE/FITTING ANODE



DRAWN: T. CRAWFORD	DATE: MARCH 6, 2006
CHECKED: J. MUSTARD	SCALE: NOT TO SCALE
APPROVED: J. MUSTARD	DRAWING No.: WR-08

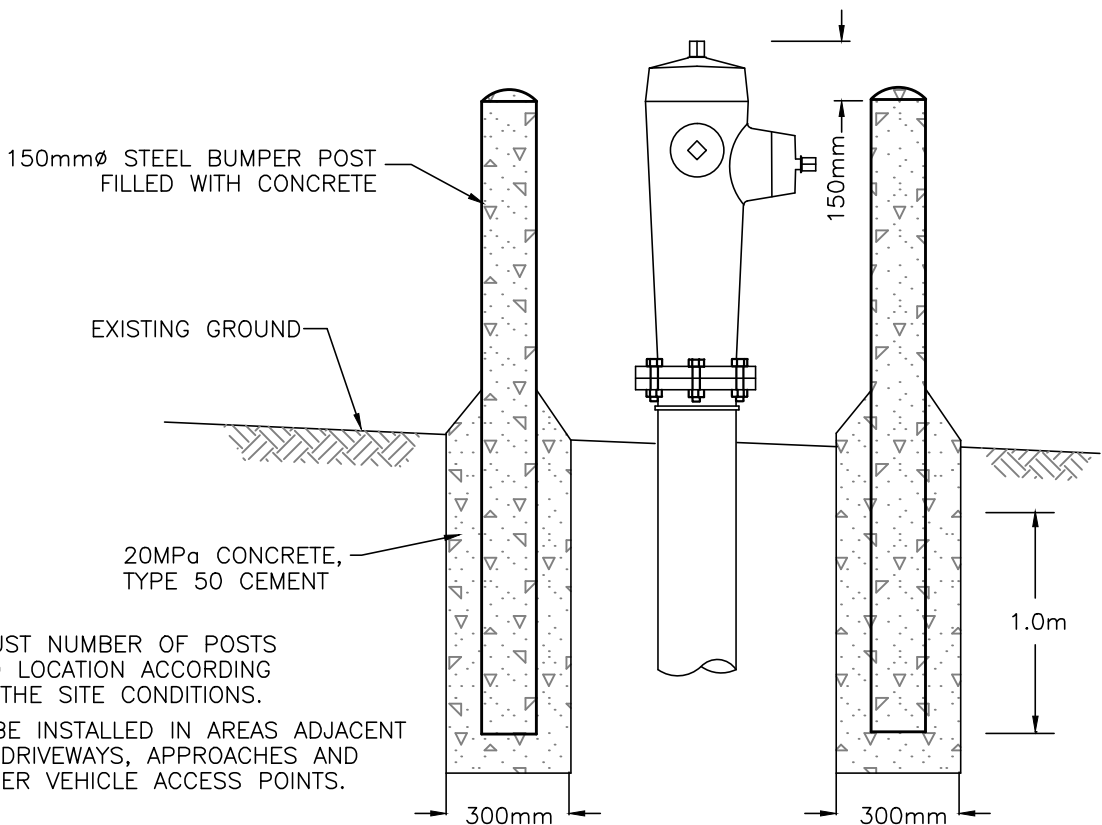
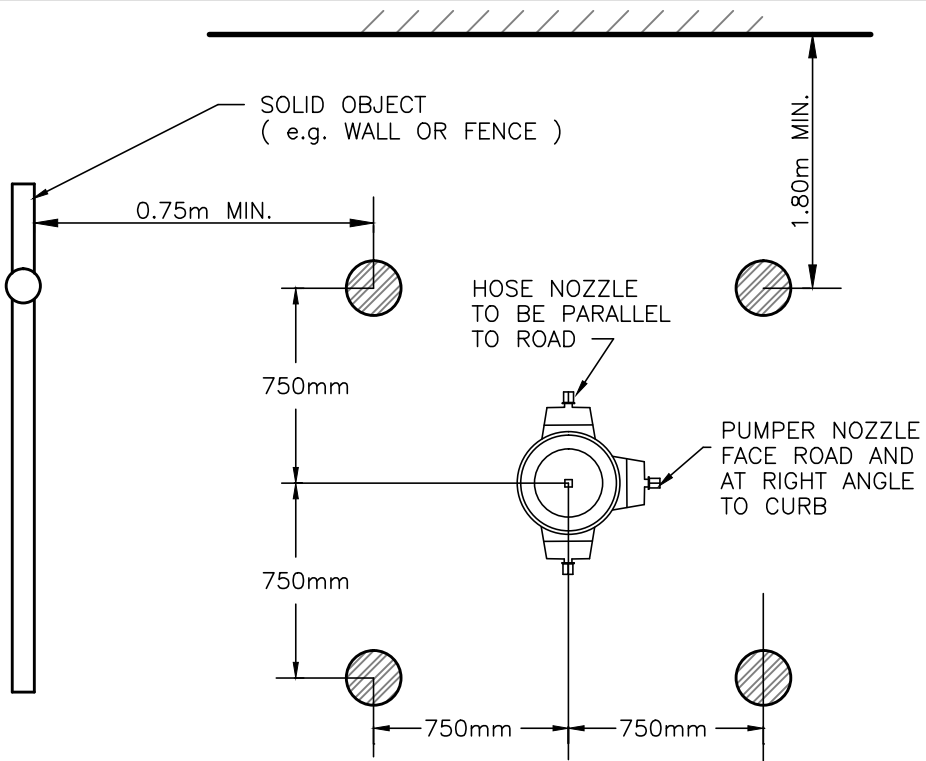

NOTE:

1. ADJUST NUMBER OF POSTS AND LOCATION ACCORDING TO THE SITE CONDITIONS.
2. TO BE INSTALLED IN AREAS ADJACENT TO DRIVEWAYS, APPROACHES AND OTHER VEHICLE ACCESS POINTS.

XREFS
C:\DETAILS\SHEET2-TK

THE CITY OF
SPRUCE GROVE

PLANNING AND INFRASTRUCTURE

REVISIONS		
DATE	DETAILS	DRAWN
02/14	DRAWING NUMBER	RP

HYDRANT BUMPER		
	DRAWN: T. CRAWFORD	DATE: MARCH 6, 2006
	CHECKED: J. MUSTARD	SCALE: NOT TO SCALE
	APPROVED: J. MUSTARD	DRAWING No.: WR-09

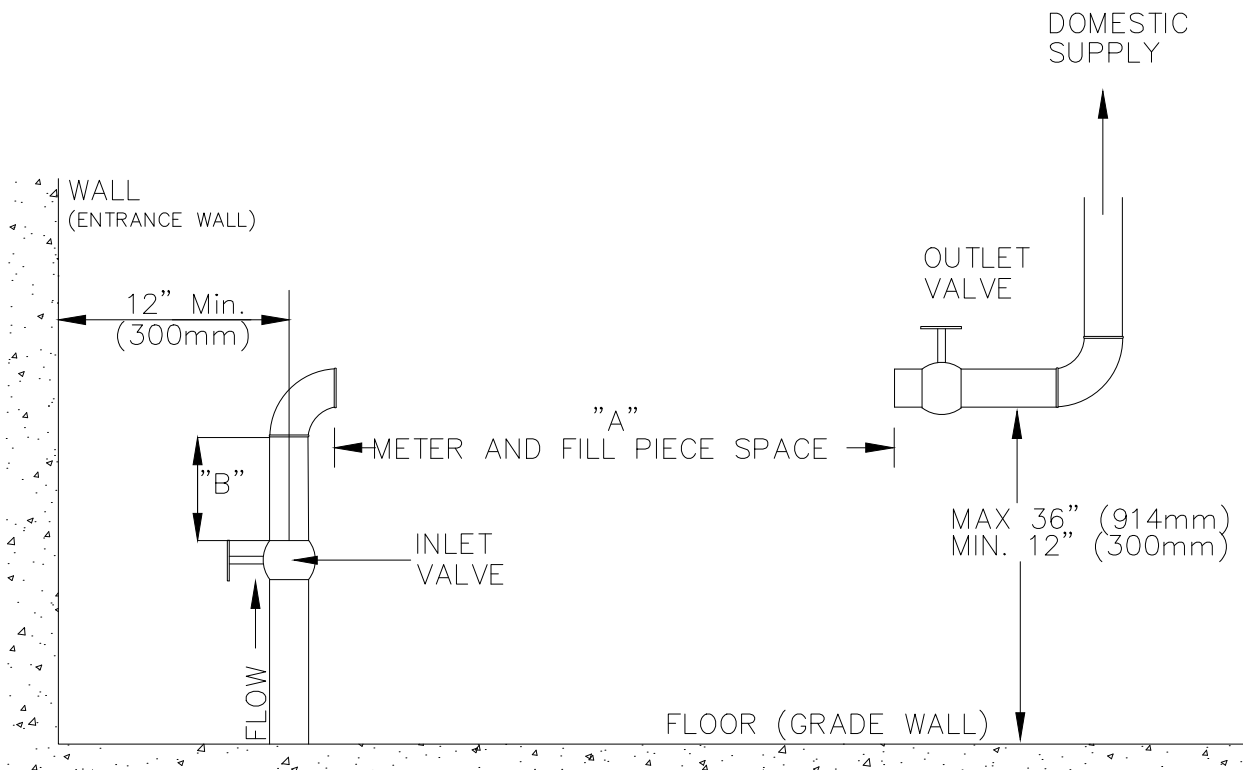

METER SIZE	"A"	"B" MAX
5/8"	12" (300mm)	1" (25mm)
3/4"	14" (356mm)	1" (25mm)
1"	16" (400mm)	2" (50mm)
1.5"	13" (330mm)	3" (75mm)
2"	17" (432mm)	3" (75mm)

* NOTE:
1.5" AND 2" METERS
ARE FLANGED END

NOTE:

- METER SETTING CONSTRUCTED USING PLASTIC PIPING ON OUTLET SIDE OF METER SHALL HAVE ADEQUATE ANCHORING CAPABLE OF KEEPING THE PIPE IN ALIGNMENT AND SUPPORTING THE WEIGHT OF THE METER, PIPE AND OTHER COMPONENTS.
- MINIMUM DISTANCE OF CENTERLINE OF PIPING ADJACENT TO METER SETTINGS TO BE 12" (300mm) FROM ANY ENTRANCE, FOUNDATION WALL, INTERIOR WALL OR ANY OTHER POTENTIAL OBSTRUCTION.
- VALVE IS REQUIRED ON THE INLET AND OUTLET SIDE OF METER SETTING ON ALL PIPE.
- PIPING FOR "A" MUST BE IN A HORIZONTAL PLANE.
- VALVES OR FITTINGS ON SIDES CONNECTING TO METER MUST BE 90° FEMALE THREADED IN 1/2" (13mm) FOR 5/8 METER, 3/4" (20mm) FOR 3/4" METER, AND 1" (25mm) FOR 1" METERS.
- BUILDINGS WITH MORE THAN ONE METER MUST HAVE A METAL OR PLASTIC TAG SECURELY ATTACHED TO THE CONTROL VALVE HANDLE OF THE METER IT SERVES. THE TAG MUST HAVE THE SERVICE ADDRESS ENGRAVED ON IT IN LETTERS OR NUMBERS AT LEAST 5mm (3/16") IN HEIGHT.
- METER LOCATION MUST REMAIN ACCESSIBLE FOR FUTURE MAINTENANCE OF METER, FITTINGS OR INSPECTION.
- BACK FLOW PREVENTION DEVICES MAY BE REQUIRED, PHONE THE CITY OF SPRUCE GROVE AT (780) 962-2611.
- NO BY-PASS ALLOWED UNLESS APPROVED BY THE CITY.

THE CITY OF
SPRUCE GROVE

PLANNING AND INFRASTRUCTURE

REVISIONS

DATE	DETAILS	DRAWN
02/14	DRAWING NUMBER	RP
03/15	CHANGES TO NOTES	RP

METER SETTING GUIDELINES



DRAWN: T. CRAWFORD	DATE: MARCH 6, 2006
CHECKED: J. MUSTARD	SCALE: NOT TO SCALE
APPROVED: J. MUSTARD	DRAWING No.: WR-10

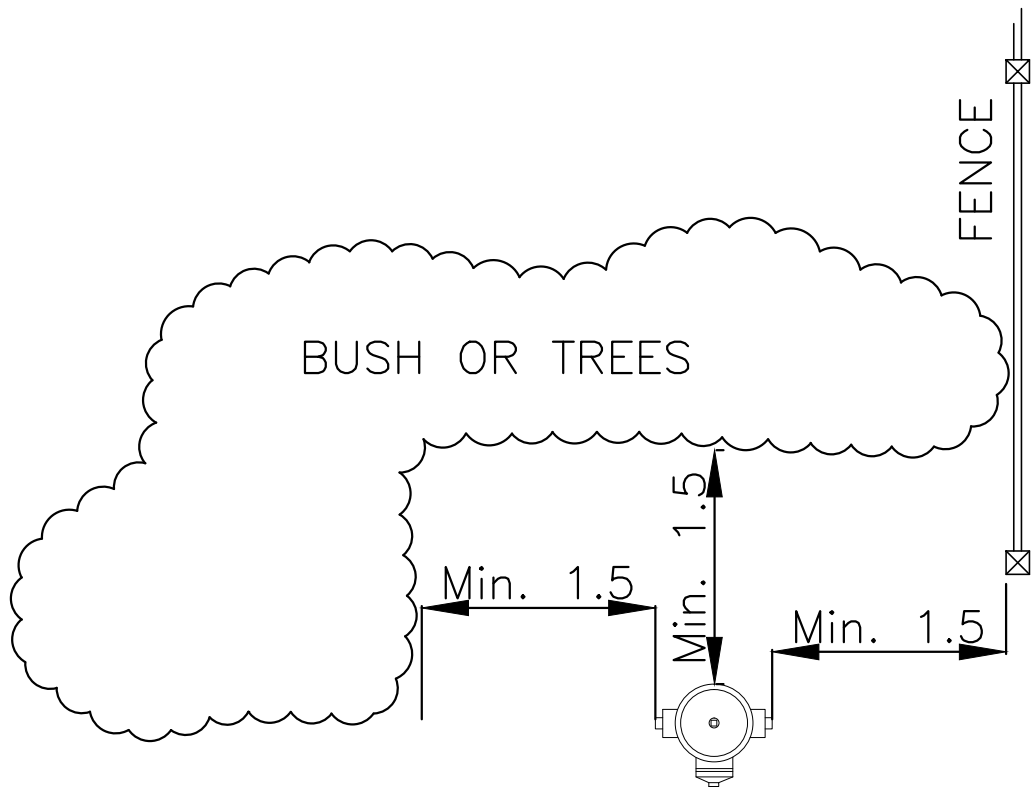

--	--	--	--	--	--

THE CITY OF
SPRUCE GROVE

PLANNING AND INFRASTRUCTURE

REVISIONS

DATE	DETAILS	DRAWN
02/14	DRAWING NUMBER	RP

FIRE HYDRANT CLEARANCE



DRAWN: T. CRAWFORD	DATE: MARCH 6, 2006
CHECKED: J. MUSTARD	SCALE: NOT TO SCALE
APPROVED: J. MUSTARD	DRAWING No.: WR-11

XREFS

C:\DETAILS\SHEET2-TK

ECLIPSE NO. 88 SAMPLING STATION

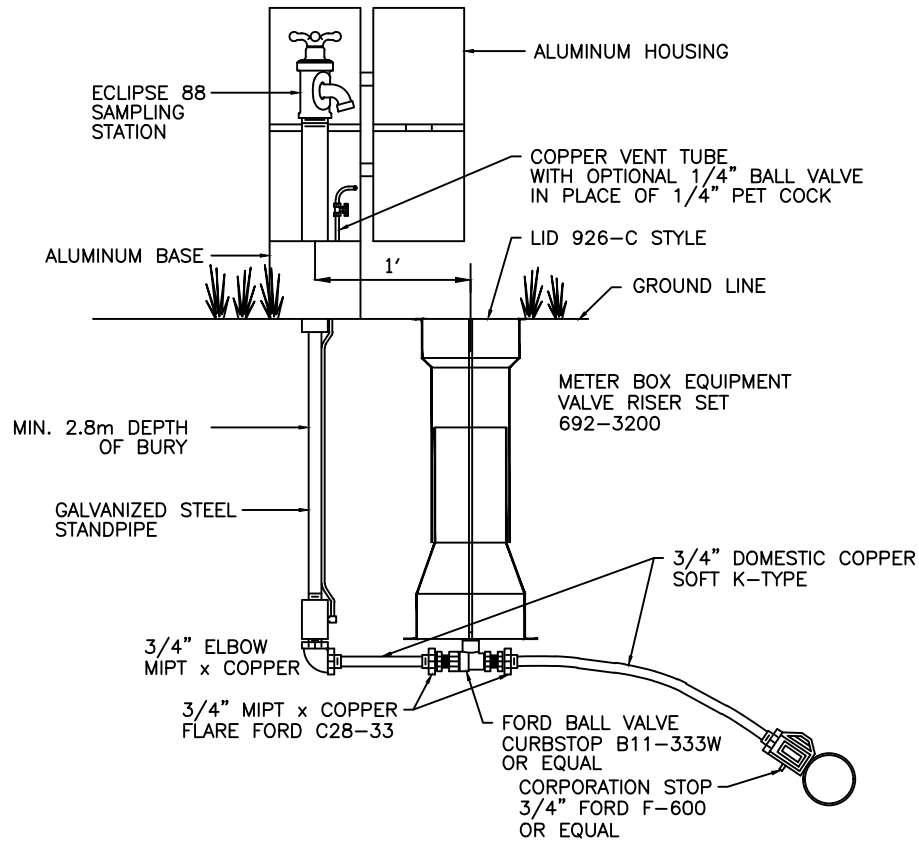

1. SAMPLING STATIONS SHALL BE 2.8M MINIMUM BURY, WITH A 3/4" FIP INLET, AND A (3/4" HOSE OR UNTHREADED) NOZZLE.
2. ALL STATIONS SHALL BE ENCLOSED IN A LOCKABLE, NONREMOVABLE, ALUMINUM-CAST HOUSING.
3. WHEN OPENED, THE STATION SHALL REQUIRE NO KEY FOR OPERATION, AND THE WATER WILL FLOW IN AN ALL BRASS WATERWAY.
4. ALL WORKING PARTS WILL ALSO BE OF BRASS AND BE REMOVABLE FROM ABOVE GROUND WITH NO DIGGING. EXTERIOR PIPING SHALL BE GALVANIZED STEEL (BRASS PIPE ALSO AVAILABLE).
5. A COPPER VENT TUBE WILL ENABLE EACH STATION TO BE PUMPED FREE OF STANDING WATER TO PREVENT FREEZING AND TO MINIMIZE BACTERIA GROWTH.
6. ECLIPSE NO. 88 SAMPLING STATION SHALL BE MANUFACTURED BY KUPFERLE FOUNDRY, ST. LOUIS, MO 63102.
7. ALL SAMPLING STATIONS ARE PROVIDED BY THE CITY OF SPRUCE GROVE BUT INSTALLED BY THE DEVELOPER.

THE CITY OF
SPRUCE GROVE

PLANNING AND INFRASTRUCTURE

REVISIONS

DATE	DETAILS	DRAWN
02/14	CHG TO NOTES	RP
02/14	DRAWING NUMBER	RP
04/19	STANDARDS UPDATE	WPS
09/20	STANDARDS UPDATE	WPS

WATER SAMPLING STATION



DRAWN: T. CRAWFORD	DATE: MARCH 6, 2006
CHECKED: J. MUSTARD	SCALE: NOT TO SCALE
APPROVED: J. MUSTARD	DRAWING No.: WR-12

XREFS

C:\DETAILS\SHEET2-TK